

Noninvasive Temperature Measurement Based on Microwave Temperature Sensor

^{1,2}Shoucheng Ding

¹College of Electrical and Information Engineering, Lanzhou University of Technology,
Lanzhou 730050, China

²Key Laboratory of Gansu Advanced Control for Industrial Processes, Lanzhou, China

Abstract: In this study, we have a research of the noninvasive temperature measurement based on microwave temperature sensor. Moreover, in order to solve the surface temperature measurement for designing microwave temperature sensor, the microwave was issued by the transmitting antenna. Microwave encountered by the measured object to return back to the measured object and then convert it into electrical signals, the use of the quantitative relationship between this signal and input noise temperature to real-time calibration. In order to calculate the antenna brightness temperature and then after signal conditioning circuit, which can show the temperature value, in order to achieve the detection of microwave temperature. Microwave-temperature measurement system hardware based on 89C51 microcontroller consists of the microwave temperature sensor, signal conditioning circuitry and chip control circuit, AD converter circuit and display circuit. The system software is by the main program, the AD conversion routines, subroutines and delay subprogram. The microwave temperature measurement characterize has: without gain fluctuations, without the impact of changes in the noise of the machine, to provide continuous calibration, wide dynamic range.

Keywords: 89C51 microcontroller, microwave sensor, temperature measuring

INTRODUCTION

Microwave is an electromagnetic wave and it has the following characteristics: devices that can be directed, easily manufactured, reflected easier when it encounter various obstacles, poor diffraction ability, good transmission characteristics, little affected by smoke, fire, dust, glare etc (Booth *et al.*, 2009). Through the transfer process; media and the dielectric constant is proportional to the microwave absorption; microwave absorption on water proves to be the best (Nakamura *et al.*, 2011). Due to this feature of the microwave itself, it has determined the microwave temperature measurement technology has the following advantages: Non-contact measurement can be achieved, most of the measurement does not require sampling; it has plenty of advantages like fast detection, high sensitivity, facilitating the automatic control and dynamic testing temperature and real-time processing could be available. It can be detected under harsh environment such as high temperature, high pressure, toxic, radiation conditions; the output signal can be easily modulated carrier frequency signal to transmit and receive to realize telemetry and remote control conveniently. Therefore, microwave temperature measurement is widely used in military, transportation, marine, industrial, agricultural, medical and other fields (Beaucamp-Ricard *et al.*, 2009). Furthermore, microwave temperature measurement is the significant matter constantly related to people's

physical and mental health, it possesses a wide range of social benefits and long-term economic benefits (Pouch *et al.*, 2010).

In this study, we have a research of the noninvasive temperature measurement based on microwave temperature sensor. Moreover, in order to solve the surface temperature measurement for designing microwave temperature sensor, the microwave was issued by the transmitting antenna. Microwave-temperature measurement system hardware based on 89C51 microcontroller consists of the microwave temperature sensor, signal conditioning circuitry and chip control circuit, AD converter circuit and display circuit. The system software is by the main program, the AD conversion routines, subroutines and delay subprogram. In our study, the microwave temperature measurement characterize is: without gain fluctuations, without the impact of changes in the noise of the machine, to provide continuous calibration, wide dynamic range.

METHODOLOGY

Principle of microwave temperature measurement system: Microwave real-time calibration of temperature measurement system is to use microwave sensors to receive a microwave radiation characteristics

which are precisely known calibration source of the radiation signal, to accurately construct a quantitative relationship between the electrical outputs of the microwave sensor receiving radiation to measure. If the linearity of microwave sensors (There is the linear relationship between the electrical output of the microwave sensor and the value of the received radiation) can be guaranteed, then according to the principle of "two points determine a straight line." the so-called "two points' calibration method" can be used. It can usually be achieved by utilizing antenna step calibration and microwave sensor which is to determine the relationship between the microwave sensor output voltage and the input of the radiometer noise temperature (Rao *et al.*, 2003). Generally, the input terminal of the microwave sensor will connect with calibration noise source that replaces antenna, measure the output voltage and get the functional relation between the output voltage and the calibration noise source temperature (Yu *et al.*, 2011). Due to square-law detector in the microwave sensors, a linear relationship exists between microwave sensor output voltage and input noise temperature, which is formula (1):

$$U_{out} = a (T_{in} + b) \quad (1)$$

Just enter two known noise temperature signal and measured its corresponding output voltage, it will be able to determine the calibration constants a and b .

In any two calibration cycle, receiver and high temperature reference source T_1 , low temperature reference source T_2 and antenna will be linked.

Its output voltage U_1 , U_2 and U'_A is shown in the following formula (2), (3) and (4):

$$U_1 = G T_1 + T_{REC} \quad (2)$$

$$U_2 = G T_2 + T_{REC} \quad (3)$$

$$U'_A = G (T'_A + T_{REC}) \quad (4)$$

By the formula (2) and (3) it can determine the signal measurement period coefficient of the calibration equation scilicet, the system gain G and the machine noise T_{REC} .

Then, take the G and T_{REC} values into the formula (2) and (3) and calculate T'_A value:

$$T'_A = \frac{(U'_A - U_2)T_1 - (U'_A - U_1)T_2}{U_1 - U_2} \quad (5)$$

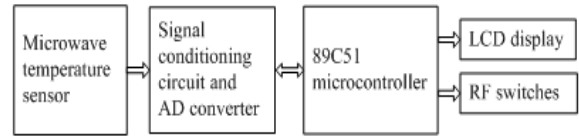

Fig. 1: Microwave temperature measurement block diagram

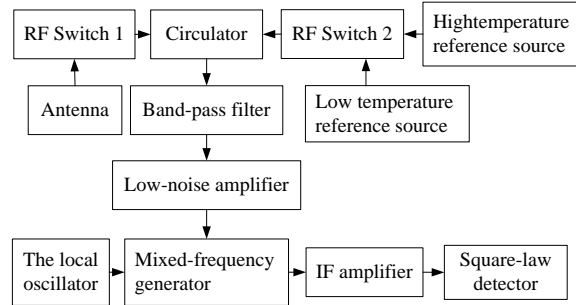

Fig. 2: The block diagram of the microwave temperature sensor

Once collected the U_1 and U_2 calibration for each measurement, even if the next cycle of the system gain G and the machine noise T_{REC} changes, the calibration equation changes along with the G and T_{REC} , that is, giving microwave sensor system a real-time calibration, reaching accurate measurement of the signal (Maughan *et al.*, 2001). It can be seen through the formula (5) that real-time calibrated microwave temperature measurement system make use of antennas, high-temperature reference source and the difference of the output voltage of the low-temperature reference source to eliminate the impact of the noise of the machine practice and took advantage of the value divided by a linear combination of the voltage difference, clear up the effects of gain fluctuations so that the machine has a good stability, the microwave temperature measurement minimum detectable signal can be close to the ideal microwave sensor's minimum detectable signal. This process, in fact, is carried out above the slow change of the system gain and system noise (Liu *et al.*, 2007).

Temperature measurement hardware construction:

The study designed microwave temperature measurement system based on the 89C51 real-time calibrated m and its core is 89C51 microcontroller. It consists of the microwave temperature sensor, signal conditioning circuits, chip control circuit, AD converter circuit and display circuit. The system block diagram shows in Fig. 1 (Ding and Li, 2011).

Microwave temperature sensor: The schematic diagram of the microwave temperature sensor is shown in Fig. 2. It is mainly composed by the antennas,

circulators, 2 RF switches, 2 thermostats source, band-pass filter, low noise amplifiers, local oscillator, mixer, IF amplifier, square-law detector circuit. Two RF switches complete the receiver input signal conversion between the 2 reference source and antenna (Zou *et al.*, 2003). Two constant temperature source provide real-time calibration standard temperature signal, let microwave blackbody heating equipment heat to 343 K (70°C) for high-temperature source, let the freezer make microwave blackbody temperature down to 233 K (-40°C) as a low-temperature source. The RF amplifier, local oscillator, mixer, putting in complete the signal amplification, square-law detector in the microwave sensors, a linear relationship exists between microwave sensor output voltage and input noise temperature.

Microwave oscillator: Microwave oscillators are made from electronic regulator, modulator, microwave oscillators, directional couplers, wavelength table, power monitor and attenuators and other components. The block diagram is shown in Fig. 3. Microwave signal generated by the microwave oscillator (Reflection-type klystron), directional coupler, all the way through the attenuator to the output, coupled with an external isolator and connected with load (Measuring circuit). It supervises the oscillator of the microwave output power and frequency by wavelength table in another road to the power monitor. (Consists of the detector and micro-ammeter)The electronic regulator provides. The stability of the electrode voltage (Cavity voltage, reflected voltage and filament voltage) of the reflex klystron, modulator produces a square wave or saw tooth wave, in order to modulate the klystron. Wavelength table is used to measure the oscillator at microwave frequencies (Wang and Liao, 2011).

RF switches: In half-duplex communication system transceiver circuit, switching technology is conventionally used to build sending and receiving channels share 1 antenna in common, so that it can reduce the volume and redundancy of the circuit. RF switches are 1 of the RF signal transmission path and signal the size of the control devices used nowadays, it has wide range of applications in many areas of wireless communications, electronic warfare, radar systems (Chauffleur *et al.*, 2004). With the development of modern wireless communication systems, mobile communications, radar, satellite communications and communications systems have higher requirements for the transceiver switch switching speed, power, capacity, integration and other aspects (Yang *et al.*, 2011).

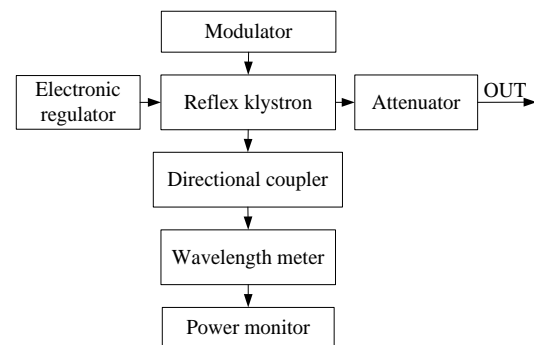

Fig. 3: Microwave signal generator block diagram

Circulator: To separate strong launching RF signal from the weak signal area of receiving electronic label, the duplexer or circulator to achieve it is used generally. It commonly used a ring in the real system transceivers which share a single antenna port. The circulator is generally composed of ferrite substrate micro-strip circulator, its output power to input power ratio is defined as the isolation of the circulator.

The central bank in the microwave circuit design features a one-way transmission of microwave power. The ideal circulator is completely absorbed microwave power in 1 direction but transmit loss-less in the opposite direction, normally used circulator requires the forward transmission insertion loss less than 1 dB, reverse attenuation greater than 20 dB (Ye *et al.*, 2006).

Circulator in the microwave circuit possesses intermediate coupling, coupling between poles, decoupling protection of emission source, reduce the frequency pulling, to interfere with, the separation of the transceiver, remove unnecessary radiation and other circuit functions. The proper use of the circulator, can effectively improve the circuit quality.

Ferrite is made of dark brown after sintering a mixture of iron oxides and metal oxide ceramic shaped magnetic dielectric material. Compared with metallic materials, it has very high resistivity, approximately 10⁷~10¹¹ Ω.cm. In terms of its conductive properties of the ferrite, it is close to the insulator. Thus the electromagnetic waves can be stuck to the ferrite internally to generate magnetic effect. Microwave electromagnetic wave generate very few losses within its transmission medium, this is a valuable features than the metal and is also an important difference with other ferrite materials. Ferrite with this feature has been widely used in microwave components. In addition, ferrite plus a constant magnetic field, electromagnetic waves in all respects will be the performance of different magnetic permeability.

The use of the transmission characteristics of the anisotropic permeability can be made irreversible

microwave devices, Ferrite isolator and circulator is the most widely used of two kinds of microwave devices. Ferrite circulator use electromagnetic waves in a gyro magnetic ferrite material transferring the applied dc magnetic field when the polarization plane of rotation of the faraday rotation effect, after properly designed, let the forward transmission electromagnetic wave polarization plane and the grounding resistance flashboard vertical, therefore attenuation is very small, reverse transmission electromagnetic wave polarization plane parallel to the grounding resistance flashboard, which is almost completely absorbed (Liu *et al.*, 2009).

In the choice of the ferrite substrate, in order to make the magnetic depletion to a minimum, should meet the following conditions: $0.4 \leq \omega_1/\omega \leq 0.7$.

where, $\omega = 2\pi f$, $\omega_1 = 2\pi f_1$, the f_1 is the intrinsic ferromagnetic resonance frequency.

According to the resonance condition of the central bank of positive and negative mode, Bessel function equation is shown in formula (6):

$$J_{n-1}(kR) - \frac{nJ_n(kR)}{kR} \left(1 \pm \frac{k}{\mu}\right) = 0 \quad (6)$$

For $n = 1$ the positive and negative rotation mode, the external magnetic field is zero when the resonance is $J'_{n-1}(kR) = 0$. A root is $kR = 1.84$, therefore: $R = 1.84/k$

where,

$$k : 2\pi f_0 \sqrt{\epsilon_0 \epsilon_f \mu_0 \mu_{eff}}$$

k : The effective wave number

R : The radius of the ferrite disc

Field theory of the junction circulator ferrite disc thickness is in formula (7):

$$h = 0.185 \frac{\omega_0 (2R)^2 \omega_f \omega_0}{bY_0} \quad (7)$$

where, $Y_0 = 0.02$, μ_{eff} is in formula (8):

$$\mu_{eff} = 1 - \left(\frac{k}{\mu}\right)^2 \quad (8)$$

Above a few formulas, the k and the μ is the diagonal of the ferrite permeability tensor and the non-diagonal components:

Y_0 : The admittance of the 50Ω micro strip line

h : The thickness of the ferrite disc

b : The normalized susceptance slope parameter

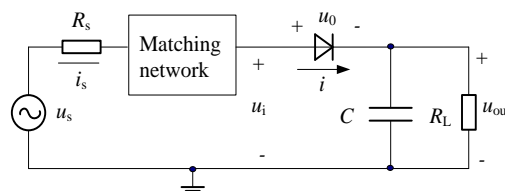

Fig. 4: Detector equivalent circuit

ω_0 : The center angular frequency of the central bank

ϵ_f : The relative permittivity of the ferrite material

μ_{eff} : Effective relative permeability of ferrite materials

ω_0 : The dielectric constant of air, $\omega_0 = 8.854 \times 10^{-12}$ F/m

μ_0 : The vacuum permeability, $\mu_0 = 4\pi \times 10^{-7}$ H/m

Square-law detector: Detector diode is the detector function of the core device, diode power detector has good sensitivity and dynamic range and is available to quickly respond to the signal envelope changes and has been gradually replaced the thermostat and thermocouple, becoming the primary means of sensing microwave power. Because of its small non-linear region, detector only meets the square-law characteristics in a small range.

When the input power exceeds the square-law range, the detector response will deviate from the square law characteristics thus affects the radiation gauge system of linear. Increasing the square-law range of the detector, a typical detector equivalent circuit is shown in Fig. 4.

Square-law range is defined as: when the output voltage deviation from the ideal square-law response to the difference between the curves 1 dB input power and PTSS, PTSS as the tangent of sensitivity for different diodes. There are 2 ways to increase the square-law range of the detector. One way is to achieve by changing the load resistance R_L , another method is to be achieved by changing the signal source resistance.

Study found that increase the square-law range of the detector by changing the R_L effect is far from ideal, this is because the R_L decreases, while increasing the 1dB compression point, PTSS increases as well and the change of PTSS amount is greater than the change of the 1dB compression point, so for the square-law range of the circuit as a whole is not improved. The signal source resistance effects are usually described using the ratio between the signal source resistance and the diode dynamic resistance to the square-law range.

The detector equivalent circuit analysis, the relationship between the detector output current and input voltage is in the formula (9):

$$i = U_{mr}^2 \frac{1}{2!} \frac{1}{2} d_2 + U_{mr}^4 \frac{1}{4!} \frac{1}{8} d_4 + \dots + Ad_1 \cos \omega t \quad (9)$$

$$+ Bd_2 \cos 2\omega t + \dots$$

In the formula, $i = \frac{1}{I_0} = \frac{i_s}{I_0}$.

i = The normalized current increment
 I_0 = The diode reverse saturation current

In the formula, $U_{mr} = \frac{U_i}{nU_T}$:

U_i = The open circuit voltage of the input signal source
 U_T = The temperature voltage and it is a constant

d_1 to d_n = The derivative, $\frac{d_i}{dU_{mr}}/U_r = 0$

d_n = Determined by η
 η = The ratio of the signal source resistance R_s and diode dynamic resistance R_i

The R_i defined as the formula (10):

$$\frac{1}{R_i} = \frac{dI}{dU} = \frac{I_0 e^{\left(\frac{U}{nU_T}\right)}}{U} = \frac{I_0}{nU_T} \quad (10)$$

The n is the diode emission coefficient, related to the material and physical structure of the diode, usually in accordance with standard IC technology produces diodes, the n is 1.02. By the formula (9), when the DC component U_{mr} mode power greater than 2, the detector response will deviate from the square law characteristics as U_{mr} growth, the size of these non-square law component by d_4, d_6, d_8, \dots . Decision, because d_n is determined by the ratio η between the signal source resistance and the diode dynamic resistance by analyzing the impact of η on the square-law range of the detector, one can make the square-law range of η values.

Obtained through the analysis: when U_{mr} is less than 4, η is equal to 0.14, the square-law range, but the U_{mr} is reduced to 70% of the maximum (i.e., $\eta = 0, d_2 = 1$). In this design, the U_{SWR} is 2.0 to 3.5; the voltage sensitivity is 0.2 to 0.8.

Microcontroller and software design: SCM is an integrated circuit chip, using technology to large scale data processing capabilities, such as with arithmetic operations, logic operations, data transfer, interrupt processing, the microprocessor CPU, Random Data Memory RAM, Read-Only Memory ROM, input/output

circuit (I/O) integrated circuits such as single chip to form a minimum and perfect computer system. Some also include timers /counters, serial port, display driver (LCD/LED driver circuit); pulse modulation circuit PWM, analog multiplexers and A/D converter circuit, these circuits can be in the software under the control of accurate, rapid and efficient completion of the mandate in advance programmers (Xun *et al.*, 2007).

The design uses Atmel's AT89 series microcontrollers (Ding *et al.*, 2012). Atmel's AT89 series microcontrollers to AT89C51 and AT89C52 represented, they are low power, low voltage, high-performance 8-bit microcontroller, in addition to MCS-51 instruction set compatibility, but also they have many advantages: the device using Atmel's high density, non-volatile memory technology production, including the internal flash memory, can be repeated more than 1000 times rewritable, effectively reducing the development costs; has a wider operating voltage range (up to 4.0~6.0 V); software, the power set CPU power saving mode to stop working to sleep, sleep period, the timer/counters, serial port stop working, RAM data is "frozen" until the next interrupt or hardware reset to be back to study before (Wu *et al.*, 2010).

Microcontroller is used in AT89C51 of MC-51 series (Qi *et al.*, 2011). AT89C51 hardware resources: 4 KB Flash memory, 128 bytes of RAM, 32 I/O lines, 2 16-bit timers/counters, interrupt structure, 2 five-source, full-duplex serial port, on-chip oscillator and clock circuitry and so on. In addition, AT89C51 from static logic design, selection of crystal frequency 12 MHz. obviously, this single chip on the development of equipment requirements is very low, shorten development time (Ding *et al.*, 2011).

Software design refers to the design of the microcontroller circuit control, information processing applications. The design takes the micro-controller as the core, AD converter, the delay control, display is needed. Therefore, the software part of the total is divided into 4 parts: main program, the AD conversion routines, display routines and delay subroutine. The design uses the C51 software programming (Ren *et al.*, 2006). Before the start of the single-chip measurement system, we must be initialized. After the initialization, the ADC 0808AD converter and the LCD display to begin data acquisition, data acquisition program to control the RF switch 3 times and then by processing the processed data is displayed through the LCD monitor, so that the microwave measures temperature system in a measurement process. The main program flow chart is shown in Fig. 5.

LCD display: Micro-controller output mode In addition to the light-emitting diodes, the digital control, is as well

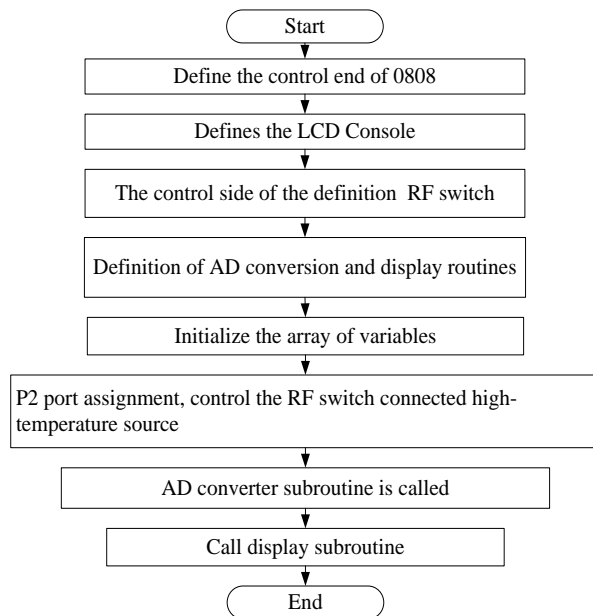

Fig. 5: Main program flowchart

as an important way (Huang *et al.*, 2011). The LCD module has become an important output device for single-chip system; LCD is widely used in portable instrumentation, smart appliances, consumer electronics and other fields. The design choices are the LCD display model LM016L it can also show that is, 32-16×2 characters and possesses low power consumption and a wide supplied range. LM016L LCD module internal character occurred memory has been stored in 160 different dot matrix characters and graphic, each character has a fixed code. Workflow is to determine the stidy of the LCD display by writing the control word and then to the corresponding need to show the local input to the memory, thus revealing the character.

CONCLUSION

To design the real-time calibrated microwave temperature measurement system based on the 89C51 Microcontroller. The system is composed of microwave temperature sensor, signal conditioning circuits, microprocessor control circuit, AD converter circuit and display circuit. Data processing, the value used is collected by a linear combination of 3 differences between the amounts of voltage, voltage difference to eliminate the impact of the noise of the machine changes. The final output is a linear combination of voltage difference divided by, divided by the result of eliminating the impact of the gain change. This not only to eliminate the noise fluctuations of the machine, but also to eliminate the gain fluctuations in the course of their study, in fact, is the slow change of the system gain and system noise on top of the target signal

measurement to obtain the minimum detectable signal. The real-time calibrated microwave temperature measurement system has been real-time calibration, the display brightness temperature to eliminate the effects of gain fluctuations and noise fluctuations, good reproducibility and stability and large dynamic range, low technical difficulty advantages.

REFERENCES

- Beaucamp-Ricard, C., L. Dubois, S. Vaucher, C. Pierre-Yves, T. Lasri and J. Pribetich, 2009. Temperature measurement by microwave radiometry: Application to microwave sintering. *IEEE Trans. Instr. Meas.*, 58(5): 1712-1719.
- Booth, J.C., N.D. Orloff and J. Mateu, 2009. Measurement of the microwave nonlinear response of combined ferroelectric-superconductor transmission lines. *Appl. Supercond. IEEE Trans.*, 19(3): 940-943.
- Chauffleur, X., L. Rabbia, P. Pons, K. Grenier, R. Plana, L. Dantas, F. Flourens, J. Kuchenbecker, D. Dubuc and A. Boukabache, 2004. Effect of membrane shape on mechanical behavior of RF switches. *Sensors Actuators Phys.*, 112(1): 148-154.
- Ding, S.C. and W.H. Li, 2011. Research on photoelectric sensor turbidity detecting system. *Sensor Lett.*, 9(4): 1571-1574.
- Ding, S.C., L.M. Xiao and G.C. Yuan, 2011. A time difference method pipeline ultrasonic flowmeter. *Lect. Notes Elec. Eng.*, 97(1): 477-484.
- Ding, S.C., A.M. An and X.K. Gou, 2012. Intelligent digital multi-purpose vehicle instrument. *Elec. Rev.*, 88(5b): 64-67.
- Huang, W., J.M. Li, L.M. Yang, Z.L. Jin, Z.G. Zhong, Y. Liu, Q.Y. Chou and F. Li, 2011. Local dimming algorithm and color gamut calibration for RGB LED backlight LCD display. *Opt. Laser Technol.*, 43(1): 214-217.
- Liu, Q.H., M. Kazumori, Y. Han and F.Z. Weng, 2007. Calculating antarctic stratospheric temperature from special sensor microwave imager and Sounder. *Geophys. Res. Lett.*, 34(15).
- Liu, Z.L., B.H. Tang and Z.L. Li, 2009. Calculation of land surface temperature based on AMSR-E data. *Sci. Technol. Rev.*, 27(4): 24-27.
- Maughan, S.M., H.H. Kee and T.P. Newson, 2001. A calibrated 27-km distributed fiber temperature sensor based on microwave heterodyne detection of spontaneous Brillouin backscattered power. *IEEE Photon. Technol. Lett.*, 13(5): 511-513.
- Nakamura, S., M. Nakamura, E. Maeda and Y. Nikawa, 2011. Noninvasive temperature measurement during moxibustion using MRI. *Asia-Pacific Microwave Conference Proceedings, (APMC)*, pp: 594-597.

- Pouch, A.M., T.W. Cary, S.M. Schultz and C.M. Sehgal, 2010. In vivo noninvasive temperature measurement by B-mode ultrasound imaging. *J. Ultrasound Med.*, 29(11): 1595-1606.
- Qi, F.Q., X.D. Jing and S.Q. Zhao, 2011. Design of stepping motor control system based on AT89C51 microcontroller. *Proc. Eng.*, 15: 2276-2280.
- Rao, C., J. Zou and X.Z. Gu, 2003. Application of fiber bragg grating temperature sensors in microwave field. *J. Trans. Technol.*, 22(10): 1-4.
- Ren, X.Y., S.C. Wu, Y. Zeng and Y.P. Bai, 2006. Temperature correlation of backscattered ultrasound time-shifts and noninvasive temperature measurement in tissue. *Chinese J. Biomed. Eng.*, 25(3): 328-332.
- Wang, D.B. and X.P. Liao, 2011. Design of symmetrical microwave power sensor. *Opt. Precision Eng.*, 19(1): 110-117.
- Wu, W.W., R.P. Ren and S.C. Wu, 2010. Study on the temperature correlation of ultrasonic attenuation coefficient in microwave hyperthermia. *China Med. Dev.*, 25(4): 15-17.
- Xun, Q.L., J.S. Kuang and Y.H. Min, 2007. At-speed current test for testing AT89C51 microprocessors. *Comput. Res. Dev.*, 44(3): 479-486.
- Yang, M.Z., C.L. Dai, P.J. Shih and Z.Y. Tsai, 2011. Capacitive RF switches manufactured by the CMOS-MEMS technique. *Microelectron. Eng.*, 88(8): 2242-2246.
- Ye, Z.B., W.C. Tang and S.S. Li, 2006. Analysis of millimeter wave microstrip circulator with a magnetized ferrite sphere by FDTD method with modified matrix pencil method. *Int. J. Infrared Millimeter Waves*, 27(8): 1109-1117.
- Yu, T., Z.T. Fan, Z.J. Xu, X.Q. Wu and H.F. Wang, 2011. Investigation on temperature distribution characteristic and its effect factors of the sodium silicate sand mould hardened by microwave heating. *Foundry*, 60(3): 238-242.
- Zou, J., C. Rao, X.Z. Gu, Y. Liu, 2003. Methods of Temperature Sensing in Microwave Field. *Piezoelectrics Acousto-optics*, 25(2): 170-174.