

Research Article

Study on High Performance Concrete Pavement of Permeability for Resisting Chloride Ion

Hou Quanhua, Yang Yuanyuan and Luo Xiaoqiang

School of Architecture, Chang'an University, Xi'an Shaanxi 710061, China

Abstract: The aim of this study is to carry on the test about the resistance to chloride permeability of the high performance concrete structure. The performance of the concrete resistance has been researched by the water-cement ratio, fly ash's content and age. The results showed that with the reduction of the water-cement ratio of the concrete, the compaction degree and the permeability resistance of the concrete are higher; With the increasing dosage of fly ash, the concrete pore system and permeability resistance have been effectively improved; Finally, the concrete combination reaction is more sufficient with the longer age and then permeability resistance is superior.

Keywords: Concrete, chloride, permeability, water-cement ratio

INTRODUCTION

Durability of concrete, is the concrete structure within a predetermined period, under natural factors, the environment and the combined effects of internal factors, without spending a lot of money to repair and reinforce its ability to maintain the required minimum performance requirements. At present, China is in a critical period of the "Twelfth Five Year Plan", the new urbanization process accelerated upward trend in the amount of concrete construction, a large number of studies have indicated that the durability of our country attaches great importance to the durability problems are concrete. Must be strictly in accordance with specifications for concrete structures for scientific and rational assessment of the durability and design to improve the durability of the design criteria. Strict quality control of the construction of concrete projects, local conditions, rational subjects, to take effective measures to ensure the safety and reliability of buildings within the design life. Therefore, the study of the durability of concrete is a long and important research tasks, has important significance.

Concrete engineering applications has been a hundred years of history, is the world's most extensive construction materials used, high durability concrete has been one constant pursuit of the goal. After the completion of the concrete structure, with the extension of their use of time, gradually reduce the concrete performance, durability and deterioration, shortening the life of the project. Durability of concrete depends largely on its permeability; permeability of the concrete for the Cl⁻penetration test can be evaluated. Chloride ion intrusion is an important cause of steel corrosion in concrete, often determines the service life of concrete structures, concrete durability is an important issue.

In winter snow season in northern China, in order to accelerate the melting of the snow road, as soon as possible to ensure the smooth flow of the main traffic roads, often using rapid de-icing salt sprinkled snowmelt solutions to road congestion and prevent freezing problems continue, where de-icing salts, chlorine salt has sufficient resources, low prices, good effects of ice and snow, etc., are widely used in the country, but most of deicing salt has a strong rot candle and ultimately lead to road salt concrete structures severely cold damage. As a branch of the durability of concrete, currently on de-icing salt damage to the concrete pavement structure has attracted attention of engineers, many domestic and foreign scholars have conducted research related aspects and has made some achievements. Mainly through mixing fibers (Quanbing and Peirong, 2004; Hongfa *et al.*, 2004a; Yi *et al.*, 2011), air-entraining agents (Hongfa *et al.*, 2004b; Power, 1954), admixtures (Ma *et al.*, 2006; Leng *et al.*, 2000), etc., to increase the density of the internal structure of concrete to improve impermeability.

Chinese scholars have done a lot of research work, (Guoqiang, 2000) In the analysis, the existing test methods for comparing frozen salt in different countries, in the study of concrete deicing salt erosion factors on the basis of the test methods to improve the salt freeze proposed quantitative evaluation method is more simple salt frozen specimen preparation methods and salt frost resistance. The effect of fly ash, expansive, three types of cement concrete factors on frozen salt erosion performance; Li and He (2010) for salts and freeze-thaw cycles coupling environment, choose the way of concrete-sided salt freeze test to study the mineral admixture, air-entraining agents improve the performance of concrete frost erosion of, the study found mixed with salt frozen ground slag

concrete erosion performance than fly ash concrete, compared with other tie than concrete, complex fly ash, silica fume concrete and air-entraining agents, salt erosion freeze the best performance; Zhonghua (2008, 2009) for the preparation of frozen road salt concrete, self-prepared frozen within the mixed-type salt admixture (referred ASN) and test methods for freezing CDF concrete reference salt, mixed with salt frozen study the performance of this admixture concrete. Analysis of admixtures on the corrosion resistance of concrete road impact; Zhang (2007) to the basic principles formulated cement concrete pavement basis, the preparation of high-performance concrete with different water-cement ratio and its corresponding the reference concrete. Under the standard curing conditions, measured 3,7,28,56 d age compressive strength and flexural strength; using ASTM C1202 method for determining electricity and Cl-permeability coefficient of permeability 28d age of Cl-through; Zhang *et al.* (2009) etc. in order to explore the 3.5% de-icing salt in the concrete structure of the surface of the role of the law of freeze-thaw damage, were Ordinary Concrete (OPC) with quick freezing method, Air Entraining Concrete (APC) and High-Performance Concrete (HPC) test beam (after the mass fraction with) salt NaCl solution freeze tests, the study found that the degree of salt damage to the OPC freeze thaw cycles increases linearly increases sharply, adding air-entraining agent can effectively reduce the degree of salt damage frozen concrete, improve its ability to freeze salt; mineral admixture type and dosage of salt for entraining HPC has a great impact on the ability to freeze; when mixed with 10% silica fume, 20% fly ash or 50% slag, air-entraining HC showed a remarkable ability to freeze salt, which is a typical characteristic of salt freeze damage was reduced, the latter grew very slowly.

This study conducted a high-performance concrete pavement structure chloride ion penetration test, using the classic DC flux method, were studied by age, the impact of water-cement ratio, fly ash three different factors on the chloride permeability and ultimately different factors influence the results obtained on the electric flux, to promote the study of anti-freeze concrete pavement structure has played a guiding role..

EXPERIMENTS

Test materials: Using the following materials: Jidong Cement production P. O 42.5 ordinary portl and cement, the fineness of 0.08 mm, sieve 4.0%; Fly: yuanbaoshan an ash density 2300 kg/m³, the specific surface area 580 m²/kg water demand of 92%. Coarse gravel aggregate production for the Beijing Sanhe particle size in the range of 5~20 mm; Changping Longfengshan fine aggregate capacity of river sand, fineness modulus of 2.8, level with the grid; super plasticizer as Beijing construct factory production DFS-II super plasticizer; tap water in Beijing.

- **Coordinate proportion:** In this study, water-cement ratio of concrete impermeability test, were selected and water-cement ratio of 0.3, 0.32, 0.34, 0.36 and 0.38 five cases tested, specifically with such Table 1 below.

This study studies the impact of fly ash concrete impermeability to select content was 0, 4, 8, 12 and 16% in three test cases, such as shown in Table 2 with concrete.

This study studies the impact of construction on concrete impermeability select age were 28, 42, 56, 70 and 84d, respectively three cases tested, specifically with such Table 3.

Table 1: Mix proportions about effect of water-cement ratio on resistance to chloride permeability of concrete

Serial number	Water-cement ratio	Dose (kg/m ³)				Super plasticizer (%)
		Cement	Water	Sand	Gravel	
1	0.30	423	127	728.8	1189.2	1.61
2	0.32	412	132	728.8	1189.2	1.53
3	0.34	405	138	728.8	1189.2	1.42
4	0.36	397	143	728.8	1189.2	1.36
5	0.38	389	156	728.8	1189.2	1.27

Table 2: Mix proportions about effect of fly ash's content on resistance to chloride permeability of concrete

Serial number	Water-glue ratio	Dose (kg/m ³)				Super plasticizer (%)	Fly ash (%)	
		Cement	Fly	Water	Sand			Gravel
1	0.4	389	0.00	156	728.8	1189.2	1.61	0
2	0.4	391.2	16.3	163	728.8	1189.2	1.58	4
3	0.4	393.3	34.2	171	728.8	1189.2	1.56	8
4	0.4	391.6	53.4	178	728.8	1189.2	1.57	12
5	0.4	384.3	73.2	183	728.8	1189.2	1.54	16

Table 3: Mix proportions about effect of age on resistance to chloride permeability of concrete

Serial number	Water-cement ratio	Dose (kg/m ³)				Super plasticizer (%)
		Cement	Water	Sand	Gravel	
1	0.4	389	156	728.8	1189.2	1.61

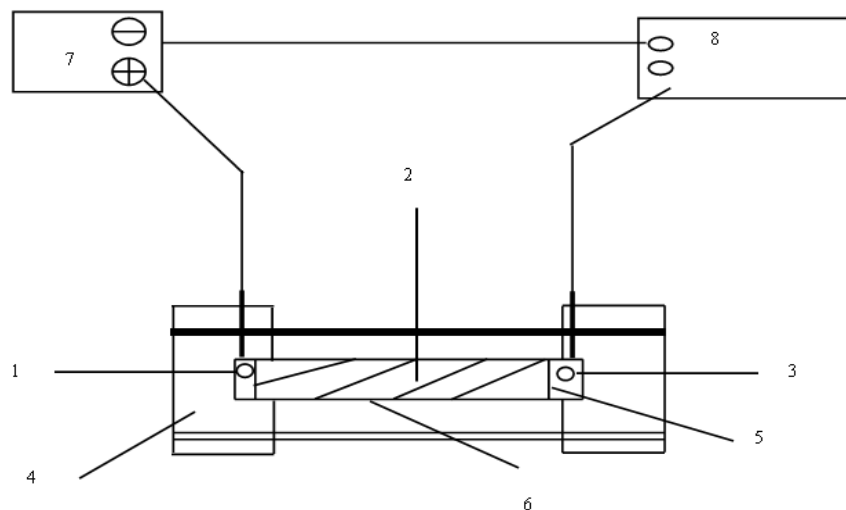

Fig. 1: ASTM 01202 Schematic diagram of experimental device; 1: 0.3 mol/L NaOH solution; 2: concrete specimens; 3: 3% NaCl solution; 4: plexiglass; 5: copper mesh electrode; 6: waterproof sealant; 7: regulated power supply; 8: ammeter

Experimental method: The tests measured each electric flux concrete work, several Chilean adopt Beijing Yi Long production DTL-A-type chloride ion flux tester to complete. Test System Requirements: host; specimens eight sets of clamps and rubber mats; connection line between the anode and cathode fixture with a host eight; power lines. Paper specimens are required for the side length of 100×100×100 mm test cubes, while pouring the test pieces, each test piece corresponding to the length of the corresponding edge produced 150×150×150 mm test cubes six in standard curing room accordance with regulatory requirements conservation 28d, the use of YAW-3000A microcomputer controlled servo pressure machine, press "GB50107-2010 standard concrete strength rating" measured compressive strength of concrete cubes.

In 1982, the United States first proposed electricity law Whiting and later by the United States AASHTO T277-81 and ASTM C1202-94 has used. ASTM C1202 chloride solution method is the essence under voltage application, the position in the negative ions (chloride ions typically) by penetrating the concrete specimen and migrate to the anode position, the amount of charge in the process of being passed chloride ion permeability of the specimen values. Figure 1 shows ASTM 01202 schematic diagram of experimental device.

Before the test, the specimen diameter advance made into 100mm, 50mm high standard test block, the test piece side glass sealing material such as plastic sealed until after the end of the sealing material is fully cured, the vacuum test block full of water saturated salt treatment. After vacuum saturated saline treated to remove the specified time, the test piece is mounted between the Plexiglas tank ends of the test piece and to maintain the electrode in contact with the

Table 4: The relationship between electric flux and chloride ion permeability grade

Electric flux Q_s (C)	Penetration level of chloride ion
$Q_s > 4000$	Q-I(Highest)
$2000 \leq Q_s < 4000$	Q- II(Higher)
$1000 \leq Q_s < 2000$	Q- III(Medium)
$500 \leq Q_s < 1000$	Q- IV(Low)
$Q_s < 500$	Q- V(Lower)

corresponding well in advance of the preparation of a good 3% NaCl solution into the cathode end of the device, the 0.3 mol/L NaOH solution was injected concentration other end (anode). Check all the preparatory work, connect the power, the device will test block both ends of the 60V DC voltage, the device will automatically record the whole process of current is applied, at the beginning of the current is not stable enough, the system 5min collected once the current value, the current stable once every 30 min time, continuous power for six hours. As long as this process by calculating all the power of the test piece, you can determine the capacity of the concrete block resistance to chloride ion penetration. Depending on the size, "the durability of concrete inspection and assessment "(JGJ/T 193-2009), the electric flux of chloride ion permeability of concrete there is a simple correspondence between grades, as shown in Table 4.

The test specimens in each test block contains the same three, the smooth polished surface of the block before the test and saturated brine, place the specimen after treatment ends to clamp them. In the test host applied DC voltage (60V) the role of the cathode chloride Cl⁻ in the solution will penetrate the test piece and the clamp to the positive migration. Finally, the host will automatically calculate the entire testing process by all the power of the test piece, in order to

determine the capacity of the concrete block resistance to chloride ion penetration.

EXPERIMENTAL RESULTS AND ANALYSIS

Effects of water-cement ratio on concrete resistance to chloride ion penetration: Water-cement ratio is the most important than the concrete mix design parameters directly affect the water-cement ratio of concrete internal porosity and pore structure, is a measure concrete density, permeability is an important parameter to a large extent determines the concrete strength and long-term durability.

Mixing grout, mortar, concrete used when the weight of water and cement ratio. Cement ratio affect the rheological properties of concrete, grout cohesion and structure after hardening its compactness and thus the composition of the material under the given circumstances, is to determine the water-cement ratio of concrete strength, durability and a host of other physical and mechanical properties of The main parameters. There is a certain optimum ratio of the cement is too large or too small will affect the strength and other properties.

Water-cement ratio is fixed according to the same kind of cement. Portland cement, ordinary portland cement, slag cement, 0.44; pozzolan cement, fly ash cement is 0.46.

The different water-cement ratio concrete block under standard conditions conservation 28d, after saturation brine, then were measured in different water-cement ratio concrete block electric flux, the resulting data is plotted in Fig. 2.

By the law of the curve in Fig. 2 and comparative analysis of experimental data, we find that the smaller water-cement ratio, the smaller the electric flux. Analysis of the reasons is because as the lower water-cement ratio, the more adequate hydration in concrete, so that the internal microstructure is more dense, the number of internal pores are also reduced, thereby increasing the permeability of concrete structures. In addition, with the increase of water-cement ratio, water-cement ratio, the same increase in the difference between the electric fluxes becomes large. Analysis is due to the greater water-cement ratio, dense worse and resistance to chloride ion penetration worse.

Effects of fly ash on concrete resistance to chloride ion penetration: With the development of concrete technology, mixing mineral admixtures in concrete more and more attention. Application of mineral admixture can improve many properties of concrete, but also an important component of the 21st century green concrete material, is now widely used in engineering practice. As we all know, the incorporation of the amount of incorporation of mineral admixtures and super plasticizer, air entraining agents, the most direct

way is to enhance the durability of concrete. Different types of mineral admixtures are mixed resulting in a series of effects, such as job performance improvement of concrete activity, adsorption and morphological effects, etc., can to a certain extent, strength and durability has also been significantly improved in a variety of mineral admixtures added, not only with each other filling, will occur between each other a series of physical and chemical reactions, have an important impact on the development to form a slurry or concrete microstructure. Mineral admixtures generally contain strong activity SiO₂, secondary reactions can occur with two slow hydration products, will generate higher strength, better durability alkaline calcium silicate hydrate, the concrete more dense, have higher strength, better durability.

In order to facilitate understanding of the role of the fly ash in coagulation, take a look at the relationship between structure and properties between coagulation. On coagulation is composed of particles of different sizes, the large gap coarse aggregate particles from coarse aggregate particles from the small stone filled; voids filled with coarse aggregate particles of fine aggregate, it is also coarse particles have fine, fine particles filling the voids between the coarse particles; grout filling the void size of aggregate thickness of the stacked body and wrapped they form a lubricating layer, so that a certain fresh concrete workability, or can force itself forming dense under its own weight. Coagulation is the hardening species complex, multi-phase composite material, its structure consists of three phases-the transition zone aggregates, cement paste and one between the complex that it is because it is very uneven quality.

Fly ash is also called, is a very fine particle in the air that can flow powdery substance of special equipment and can be collected, we usually referring to the fly ash coal-fired power plants in the ground pulverized coal boiler after burning the collected dust collector material discharged from the flue. Fly ash as admixture is added to concrete, can improve the workability of concrete durability performance, improve the density of concrete, chlorine and other harmful substances from the permeability is greatly reduced, thus extending the life of concrete structures to improve durability.

This study tests the different fly ash concrete blocks under standard test conditions conservation 28d, after the same treatment be saturated brine and fly ash were measured in different electric flux concrete block and the resulting data is plotted a curve shown in Fig. 3.

By law curve in Fig. 3 and comparative analysis of experimental data, we find that the higher the fly ash, electric flux is smaller. Analysis of the reasons is because incorporation of fly ash can significantly reduce the porosity and pore hardened grout transition zone between the aggregate and the cement slurry, ash

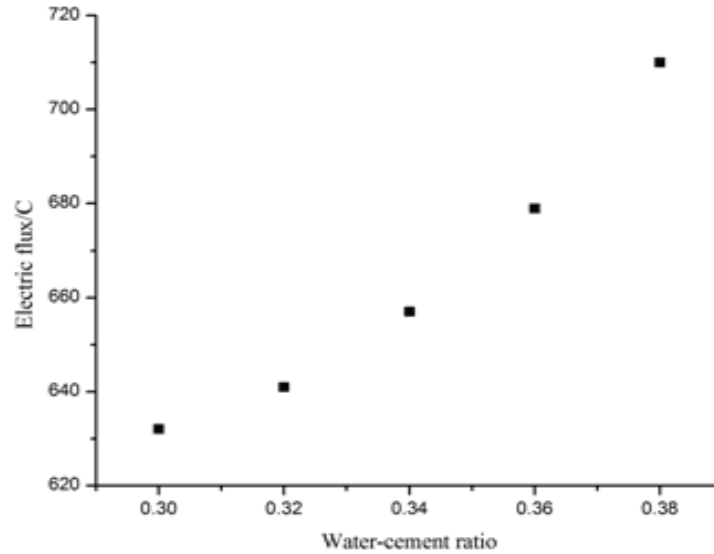

Fig. 2: Effect of water-cement ratio on resistance to chloride permeability of concrete

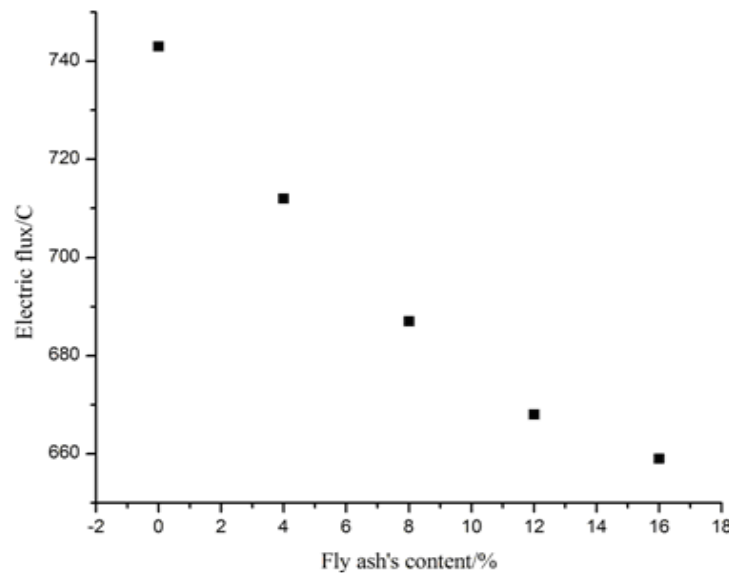

Fig. 3: Effect of fly ash's content on resistance to chloride permeability of concrete

large surface area, higher activity than can quickly occur secondary hydration, improve the density of concrete, improve the performance of concrete frozen salt. With the increase of fly ash, the ash generated by the reaction of hydration products fill the gaps in the hardened cement paste, significantly reducing the Cl⁻ diffusion and improve the concrete compactness; addition, with the fly ash the increase in the difference between the same fly ash, reducing the amplitude of the electric flux becomes smaller, indicating that with the increase in fly ash content, structure, reducing the magnitude of the density enhancements, improved gradually reduce the degree of impermeability.

In addition, replace the same amount of fly ash as a cement admixture, can enhance the adsorption of chlorine from the physical chemistry. Literature that flies ash from the early curing concrete chloride is mainly due to the role of unhydrated powder PFA has a larger surface area and special space surface structure. ash surface through pores communicating with the internal cavity, so that the concrete on the active chlorine adsorption and reaction from the fly ash on the surface of a sphere or through hole carried out in the interior of the cavity, while increasing the adsorption and reaction sites in the late hydration of fly ash concrete is added to increase the number of hydration products, secondary hydration reaction of fly ash will

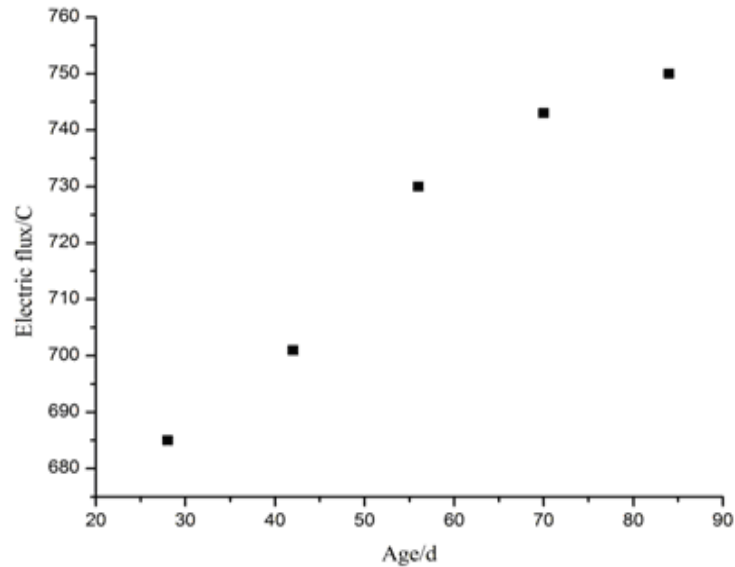

Fig. 4: Effect of age on resistance to chloride permeability of concrete

consume system of Ca (OH) 2 and generates more CSH gel C4AH9. C4AH9 reaction with chlorine from the salt Fei, C-S-H gel due to its larger surface area, by the electrical double layer effect, the generation of chlorine from the strong adsorption solidification. reduced from the free chlorine concentration, thereby increasing the concrete resistance to chloride penetration from the performance.

Effects of age on concrete resistance to chloride ion penetration: Resistance to chloride ion permeability of concrete impact greatly on age, whether or not mixed with mineral components, concrete instars, the corresponding electric flux there are some differences.

The different ages of concrete block in the conservation of 28 days under standard conditions, followed by saturated brine and finally instars were measured electric flux concrete block and the resulting data is plotted, shown in Fig. 3. By law curve in Fig. 3 and comparative analysis of experimental data, we find that the longer the age, the greater the electric flux, but the same age interval, an increase of electric flux decrease; 70 and 84d electric flux or less analysis of the reasons is because the fundamental factors affecting the permeability of concrete is the porosity and pore characteristics, the lower the concrete porosity, permeability, the better. With the extension of age, more adequate hydration in concrete, concrete density growing, impermeability improved; and age, the smaller the density change, the more improved impermeability is not significant.

Figure 4 shows that age is not a big difference of concrete anti-chloride ion permeability, the same as that discussed with other scholars. Setting and hardening of concrete is the result of chemical and physical changes occur between cement and water, the initial hydration

of concrete in many large pores, large total pore volume, as time increases, the degree of increase in the fine pores of the system, an increase in the gel pores, the pore volume and pore structure can be rapidly reduced. Chloride permeability test results along with the degree of hydration of the deepening decreases.

CONCLUSION

This study conducted a high-performance concrete pavement structure chloride ion penetration test to study the water-cement ratio, fly ash, age, respectively, on three different parameters affect the impermeability of concrete through experimental data analysis, the following few conclusions:

- Test data for this test three different water-cement ratio of pavement performance concrete structures can be obtained results were compared with the decrease of water-cement ratio, high-performance concrete pavement structure enhanced impermeability.
- High-performance concrete test data for different analysis and comparison of fly ash, fly ash shows that the higher the better corresponds to the impermeability of high performance concrete pavement structure.
- From the experimental data in this article. With the extension of age, high performance impermeability of concrete pavement structure to a certain extent.

REFERENCES

- Guoqiang, Z., 2000. Study the performance of concrete erosion frozen salt fly ash. Low Temp. Archit. Technol., 4(2): 3-5.

- Hongfa, Y., S. Wei and W. Qing, 2004a. Freezing-thawing durability of fiber reinforced high performance concrete exposed to salt lakes. *J. Shenyang Arch. Civ. Eng. Univ.*, 20(2): 130-135.
- Hongfa, Y., S. Wei, Z. Lianghui and W. Qing, 2004b. Research on freezing-thawing durability of air-entrained concrete exposed to salt lake. *J. Wuhan Univ., Technol.*, 26(3): 15-18.
- JGJ/T 193-2009. Standard for Inspection and Assessment of Concrete Durability [S].
- Leng, F., N. Feng and X. Lu, 2000. An experimental study on the properties of resistance to diffusion of chloride ions of fly ash and blast furnace slag concrete. *Cement Concrete Res.*, 30(6): 989-992.
- Li, W. and Z. He, 2010. Blended frozen salt erosion impact on the performance of concrete materials and air-entraining agent. *Ind. Construct.*, 6: 12-15.
- Ma, K.L., Y.J. Xie and L.B. Li, 2006. Research on the capability of permeability and frost-resistant of concrete in NaCl solution. *Concrete*, 200: 15-17.
- Power, T.C., 1954. Void spacing as a basis for producing air-entrained concrete. *ACI J. Proc.*, 50(9): 741-760.
- Quanbing, Y. and Z. Peirong, 2004. Effect of steel fiber on the deicer-scaling resistance of concrete. *J. Build. Mater.*, 7(4): 376-378.
- Yi, S.T., S.W. Pae and J.K. Kim, 2011. Minimum curing time prediction of early-age concrete to prevent frost damage. *Constr. Build. Mater.*, 25(3): 1439-1449.
- Zhang, M., 2007. Permeability of high performance concrete pavement resistance to chloride ion. *Low Temp. Archit. Technol.*, 1: 14-16.
- Zhang, Y., Y. Hongfa and W. Jiachun, 2009. Injury law a concrete structure of the surface salt freezing conditions. *Chinese J. Highway*, 22(4).
- Zhonghua, L., 2008. Study road salt frost resistance of concrete. *Sichuan Univ., Eng. Sci. Edn.*, 5: 79-83.
- Zhonghua, L., 2009. Salt frost resistance of concrete. *J. Jilin Univ., Eng. Sci.*, 4: 926-931.