

Research Article

Novel Three-phase Four-wire UPQC Topology Using Adaptive-network-based Fuzzy Inference System for Voltage Sag Compensation

N. Kiruthika Indumathi, R. Padmapriyadharishini and V. Ramakrishnan
Department of EEE, St. Peter's University, Chennai, Tamil Nadu, India

Abstract: This Study Proposes the novel four wire UPQC topology for Non-linear load and three-phase fault compensation. The electrical power quality is affected by many factors like harmonic pollution due to non-linear loads such as large thyristor power converters, rectifiers and the voltage/current flickering due to arc furnaces and also the sag and swell creation due to the switching of the loads. To overcome the above mentioned problems use of a combined system of shunt and active series filters like Unified Power Quality Conditioner (UPQC) topology. This device contains the integration of a shunt active filter together with a series active filter in a back to back configuration to simultaneously compensate the supply voltage and the load current. Also, it is used to mitigate any type of voltage and current fluctuations and power factor correction in a power distribution network. In this study a novel design of UPQC proposed for voltage sag compensation by using Adaptive Network based fuzzy inference system (ANFIS). This proposed controller has been provided the dynamic control of shunt and series converter operation. It has the combined operations of FL and Artificial Neural Network (ANN) relative advantages and also a powerful processing tool with both advantages can be obtained by combining them together. The simulation results have verified by using MATLAB/SIMULINK environment.

Keywords: Artificial Neural Network (ANN), Adaptive Network Fuzzy Inference System (ANFIS), Fuzzy Logic (FL), power quality, series Active Power Filter (APF), shunt APF, Unified Power Quality Conditioner (UPQC), voltage sag

INTRODUCTION

Recently, the survey of Power Quality experts mention that 50% of all Power Quality problems are related to grounding, ground bonds, neutral to ground voltages, ground loops, ground current and other ground associated effects. Here, the one of the most power quality problem is voltage flicker, which is a repetitive voltage magnitude change of low frequency and non linear load. The combination of Series and Shunt Active Filter like UPQC is used to compensate flicker fast enough for proper operation of the system. The above mentioned control strategy can be focus on the voltage sag, swell, harmonic and flicker compensation. The power of the indicated approach used to comparable with instantaneous PQ theory without loss of stability. It can be achieved by using fuzzy controller benefits over PI controller (Agrawal *et al.*, 2014; Chourasia *et al.*, 2014).

The compensation of voltage and current of UPQC can be achieved by using reference generation scheme along with the switching control configuration. Here, the voltage control mode can be make the bus voltage at

a load terminal sinusoidal against any unbalance, harmonic, flicker in the source voltage, unbalance and harmonic in the load current. Similarly, the current control mode can be draws a balanced sinusoidal current from the utility bus irrespective unbalance, harmonic in either source voltage or load current (Ghosh and Ledwich, 2001).

The design of UPQC consists of a custom power device with integrated shunt and series active filters for power quality improvement. This configuration can be able to compensate the unbalance in source voltage, load current and also improves the power factor. The P-Q theory can be applied for balanced three phase system for each phase of unbalanced system independently. The three phase four wire system based UPQC is used able to compensate the unbalanced, harmonic components, power factor and short duration voltage variations. The better performance of UPQC configuration is achieved by using control strategy of PQ theory (Sandhya *et al.*, 2013; Babu and Dash, 2012; Monteiro *et al.*, 2012).

The neuro-fuzzy based system used to implementation of advanced Power Stability System

Controller (PSSC) for power quality improvements. This controller can be used to prove the stability shortest time and with minimum disruption. The modified UPQC topology is used to help the DC link voltage requirement for the combination of series and shunt active filters. This above configuration gives the less THD in the source currents and load voltages with reduced DC-link voltage as compared to the conventional UPQC topology. The fuzzy logic based control scheme is adopted to adjust the reference signal for the system. The detection of inrush current conditions on recognized accurately from internal faults less than one cycle after the occurrence of disturbance (Sallama *et al.*, 2012; Karanki *et al.*, 2013; Elmitwally *et al.*, 2000; Esmailian *et al.*, 2011).

The improvement of power quality can be achieved by using the UPQC with Fuzzy Logic Controller (FLC) and Artificial Neural Network (ANN) controller with respect to the conventional proportional integral (PI) controller. The better response time and derivation of compensation signals can be reduces the significantly with improved accuracy (Kumar and Sastry, 2011).

The moderation of power quality problems can be identifying by using Unified Power Quality Conditioner (UPQC). The above configuration deals with voltage and current imperfections simultaneously with the help of two different control schemes. The adaptive Network based inference system used to process of the logging data and identifies lithology. Also, it is used for accurate identification of faulty protection devices using operating status of main and back up protection devices (Hembram and Tudu 2015; Jia, 2012; Ghani *et al.*, 2010).

The better dynamic performance of shunt active power filter can be achieved by using the neural network filter for reference current generation and fuzzy logic controller for DC voltage control. The ANFIS based control scheme used for parallel active filters adaptation of the control mode to changes in the amplitude and spectral composition of the load current. In order to overcome the PQ problems such as like power-factor correction, load balancing, current harmonic mitigation, voltage harmonic mitigation and source neutral current mitigation (Jha and Dubey, 2011; Pal *et al.*, 2010; Husev *et al.*, 2011).

In this study presents the novel design of Unified Power Quality Conditioner (UPQC) based topology for voltage sag compensation. The Adaptive Network based Fuzzy Inference System (ANFIS) used to control the integration of shunt and series active power filters (APF). The reference current generation based ANFIS hysteresis controller has been designed for series converter and ANFIS based PWM pulse generation for shunt converter. Here, the back to back converter configuration having series and shunt LC filters for each converter respectively.

In shunt converter side contain the series connection of capacitor used to reduce the requirement of DC link voltage and derive the power factor correction. Also, the split range of capacitor is used for reducing the capacitor voltage stress. The overall performance of proposed topology has been verified by using MATLAB/SIMULINK software.

MATERIALS AND METHODS

The Power Quality is an important issue for electricity user at all levels of usage, particularly industries and the services sector. The most common problem of power quality such as Voltage sags, Voltage variations, Interruptions Swells, Brownouts, Blackouts, Voltage imbalance, Distortion, Harmonics, Harmonic resonance, Inter-harmonics, Notching, Noise, Impulse, Spikes, Ground noise, Common mode noise, Critical load, Crest factor and Electromagnetic compatibility. The Power quality problems can be basically started at four levels of the system for delivering the electric power. The first one is consider as Power plants and the entire area of transmission system. The second one includes the transmission lines and major substations. The third one contains the distribution substations, primary, secondary power lines and distribution transformers. The fourth one includes the service equipment and building wiring.

The Power disturbances can demand of voltage, current or other parameters and typically evidence as dips, swells, harmonic distortion, unbalance, flicker, transients and additional power factor. The most common factors of power quality problems consider as large equipment of starting up/down, overloaded circuits, Improper wiring with grounding and harmonics. The major type of power quality issues are consider as:

- Voltage Swell Creation
- Voltage Sag Creation
- Interruption
- Harmonics
- Distortion

Creation of voltage swell: The creation of Voltage Swell is increase in voltage between 1.1 to 1.8pu at power frequency for duration from 0.5 cycles to 1 min. This swell condition is based on the function of fault location, system impedance and grounding. The corresponding waveform of voltage swell is shown in Fig. 1. The Voltage swells are characterized by using RMS magnitude and duration. It can also be caused by de-energize of a very large load.

Generally, the swell can occur due to a single line-to ground fault on the system and also result in a temporary voltage rise on the Un-faulted phases.

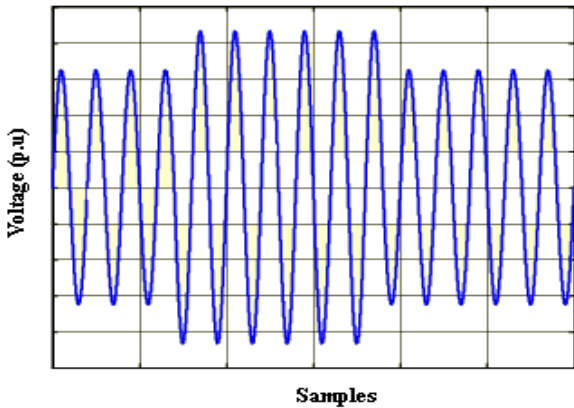

Fig. 1: Voltage swell waveform

Creation of voltage sag: The creation of voltage sag is decrease in voltage between the 0.1 to 0.9pu at the power frequency for the duration from 0.5 cycles to 1 min. It is usually associated with system faults and can also cause by energisation of heavy loads at starting of large motors. The voltage sag waveform is shown below in Fig. 2. The majority of voltage sags and the voltage drop to about 80% of nominal value on the

parallel feeders. The faulted feeder may have a lower sag value or may result in an outage when the fault cannot be cleared.

It is mostly caused by system fault and last for duration laying out from 3 cycles to 30 cycles depending on the fault clearing time. The voltage sag can be occurring on the utility systems both at distribution voltages and transmission voltages.

Power interruption: The Interruption is considered as power quality problem with the most perceivable effect on facilities. It generally impresses the industrial sector, particularly the continuous process industry. Additionally, the communication and information processing business is also significantly disturbed. The power interruption waveform is shown in Fig. 3.

It can be occurs when the supply voltage or load current decreases to less than 0.1 pu for a period of time but not exceeding 1 min. The Power interruptions of zero-voltage events can be caused by weather, equipment malfunction and transmission outages. Also, it can occur on one or more phases and typically short duration events for the vast majority of power interruptions.

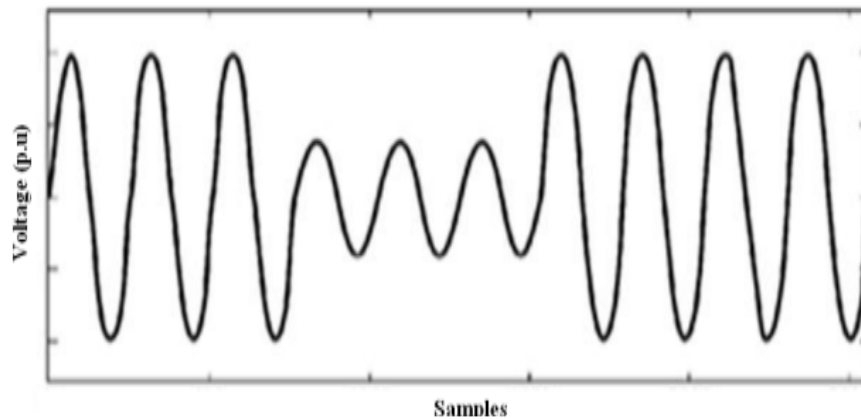

Fig. 2: Voltage sag waveform

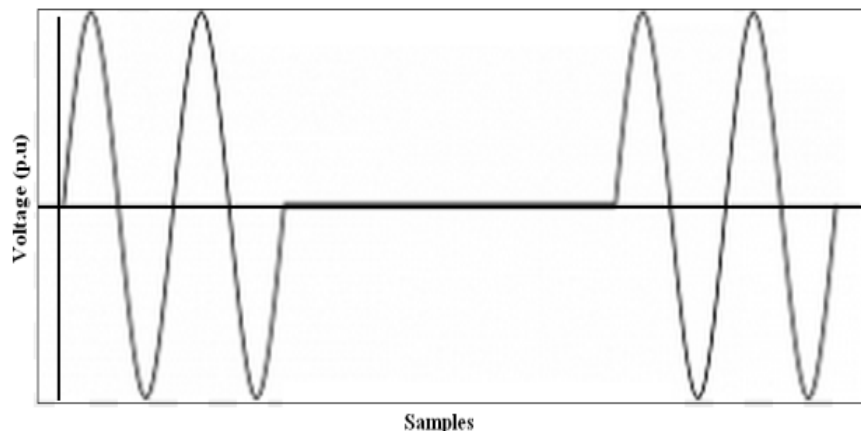

Fig. 3: Interruption waveform

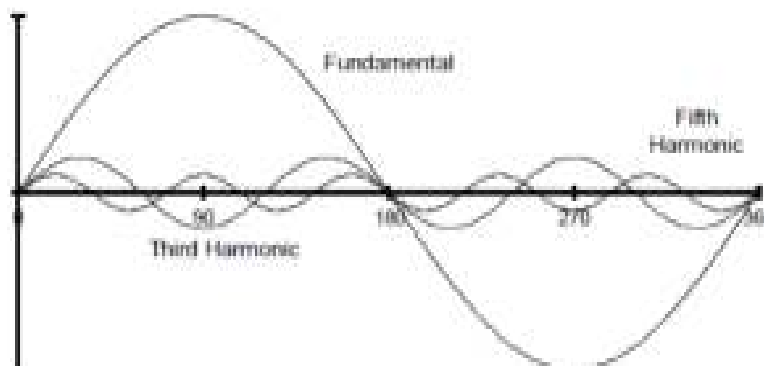

Fig. 4: Harmonic distortion waveform

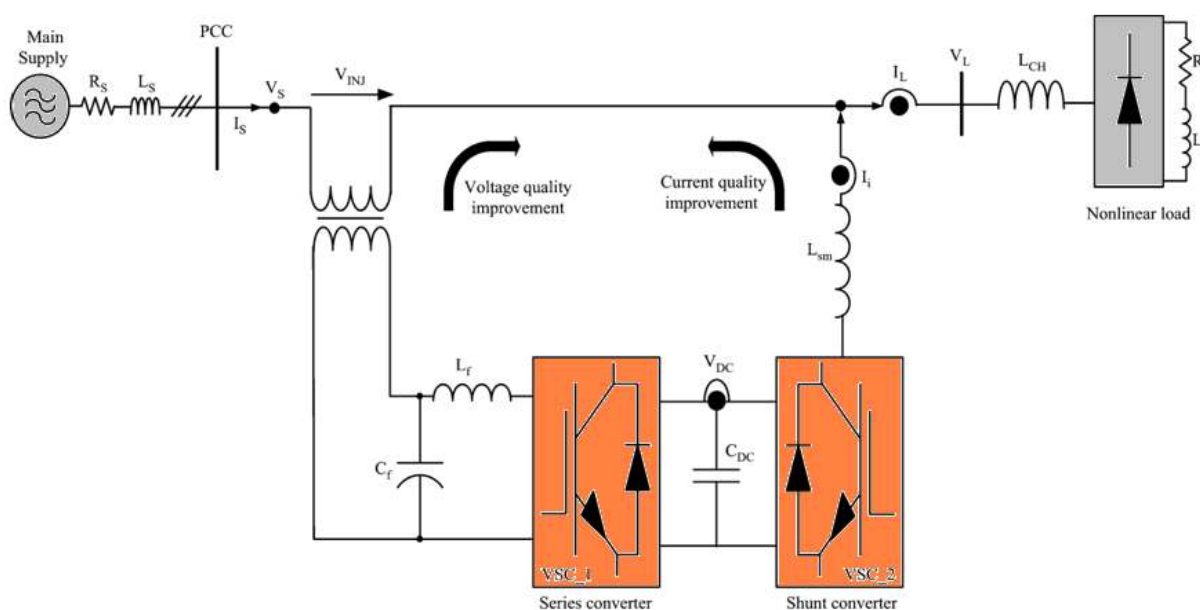

Fig. 5: Schematic diagram of UPQC configuration

Harmonics: The harmonics of signals are described as the interference in an AC power signal created by frequency multiples of the sine wave. The variable frequency drives and UPS systems are major source of harmonics being injected into the electrical system and without proper protection of grid. The sinusoidal voltages and current are having the frequency with integer multiples of the fundamental frequency.

Distortion: The description of power distortion on voltage and current may be assuming the non sinusoidal shape. These corresponding waveforms consider the sum of different sine-waves with different magnitude and phase multiples of power-system frequency. The different kind of harmonic distortion is shown below in Fig. 4.

The combination of the sine wave with all the type order of harmonics creates a new and non-sinusoidal wave of entirely different shape. The corresponding change of the wave is called as harmonic distortion. The measurement of harmonics is found out by using a

term called as Total Harmonic Distortion (THD) of current or voltage. The power quality issue on the voltage and current at the steady state conditions are determined by the different harmonics present.

UPQC basic configuration: The arrangement of UPQC consists of the integration of series active power filter, shunt active power filters, connected back-to-back on the dc side and sharing a common DC capacitor. The UPQC is one of the major custom power solutions for capable of mitigating the effect of supply voltage sag at the load end and at the Point of Common Coupling (PCC) in a distributed network.

It also used to prevent the propagation of the load current harmonics and improves the input power factor of the load. This configuration is used to maintaining a balanced sinusoidal nominal voltage at the load bus side, eliminating harmonics in the source currents, load balancing and power factor correction. The Schematic configuration of UPQC arrangement is shown in Fig. 5.

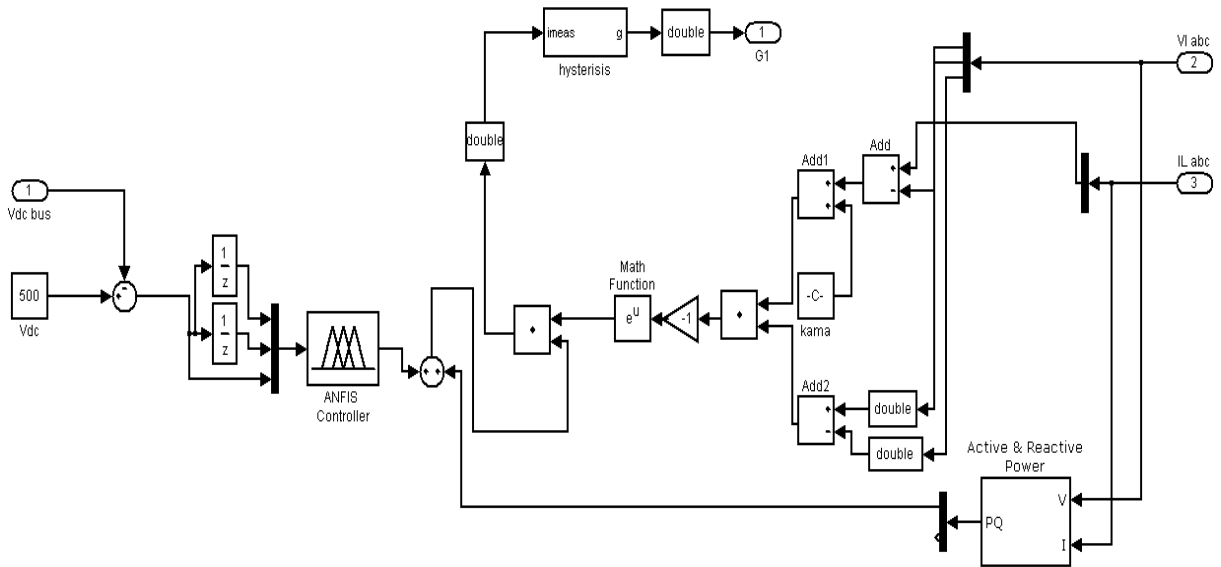

Fig. 6: Block diagram of series converter control topology

Here, the one inverter is controlled as a variable voltage source in the series Active Power Filter (APF). The other inverter is controlled as a variable current source in the shunt active Power Filter (APF). The series APF used to compensate for voltage supply disturbances such as including harmonics, imbalances, negative and zero sequence components, sag, swell and flickers. Similarly, the shunt APF converter can be used to compensate for load current distortions like caused by harmonics, imbalances, reactive power and perform the dc link voltage regulation.

In steady state analysis of UPQC describe the voltage injected by series APF must be equal to the difference between the supply voltage and the ideal load voltage. Hence, the series APF acts as controlled voltage source. Here, the function of shunt APF is used to maintain dc link voltage at constant level. Additionally, this type of shunt APF provides the VAR required by the load such as the input power factor will be unity and only fundamental active power will be provided by the source.

ANFIS based control strategy: The adaptive Network Fuzzy Inference System (ANFIS) based system used to controlling the series and shunt active power filters for power quality improvement. This kind of artificial neural network based on the Takagi-Sugeno fuzzy inference system. Also, it integrates both artificial neural networks and fuzzy logic principles for capture the benefits of both in a single framework. However, the ANFIS uses either back-propagation or a combination of least squares estimation and also the back-propagation for membership function parameter estimation.

In addition, the initial parameter settings of the ANFIS are intuitively reasonable though without a

priori knowledge and leads to fast learning that captures the underlying dynamics. In this study ANFIS networks have been successfully applied to classification tasks, rule-based process control, pattern identification and similar problems. Here a fuzzy inference system comprises of the fuzzy model proposed by Takagi, Sugeno and Kang to validate a systematic approach to generate fuzzy rules from an input/output data set.

Series converter control topology: The purpose of ANFIS is used to generate the discharging DC link Voltage by using bias voltage generator. Also, the generation of fuzzy rules can be trained by using neural network. Here, it can be obtained the desired output performance of inference system. The reference current generation based hysteresis controller can be designed for series converter.

The main function of series converter is used to compensate the voltage disturbance in the source side due to the fault in the distribution line. These converters can be operating as a controlled rectifier and also it supply drawn from the main source. Similarly, it can act as inverter during supply inject from dc link to main supply. Hence, this converter act as a rectifier as well as inverter depends upon the requirements. The control block diagram of series converter is shown below in Fig. 6.

The ANFIS based hysteresis controller method is used to optimize the response of series converter. The Sinusoidal voltage controlling strategy of load is used to control the series part of UPQC. Here, the series converter of UPQC is controlled by the all voltage distortions and maintains load voltage of three phase balanced sinusoidal through compensation purpose.

The synchronous reference frame theory is applied to achieve the above configuration. The regulation of

the voltage at Point of Common Coupling (PCC) through the three-phase reference supply currents has component. This corresponding component of reference supply currents placed in-phase with the voltage at PCC. It is very necessity to feed active power to the load and the losses of UPQC. The second component consider as quadrature component with the voltage at PCC.

Shunt converter control topology: The ANFIS based PWM pulse generation used to control the shunt converter of UPQC configuration. Generally, the shunt inverter is used for voltage regulation at the point of connection interposing a seasonable reactive power flow into the line and to balance the real power flow exchanged between the series converter and the transmission line. The series converter can be used to control the real and reactive line power flow inserting

an opportune voltage with controllable magnitude and phase in series with the transmission line.

The shunt converter has function of compensating the current related problems. The DC link voltage is maintained by with the shunt controller. The *abc* to *dq0* transform is inversed and converted to *abc* signal. This corresponding signal is given as the reference signal and also the measured signal is given to the hysteresis band PWM. It is used to produce the pulse signals for the operation of shunt converter. The control diagram of shunt converter is shown below in Fig. 7.

The switching control strategy of shunt converter is used by PWM pulse generation method. The purpose of this shunt controller is used to compensate the reactive and harmonic component of load current. The ANFIS based controller is used to regulate the DC-link capacitor voltage. This controller acts as a controlled current generator for compensation of the load current

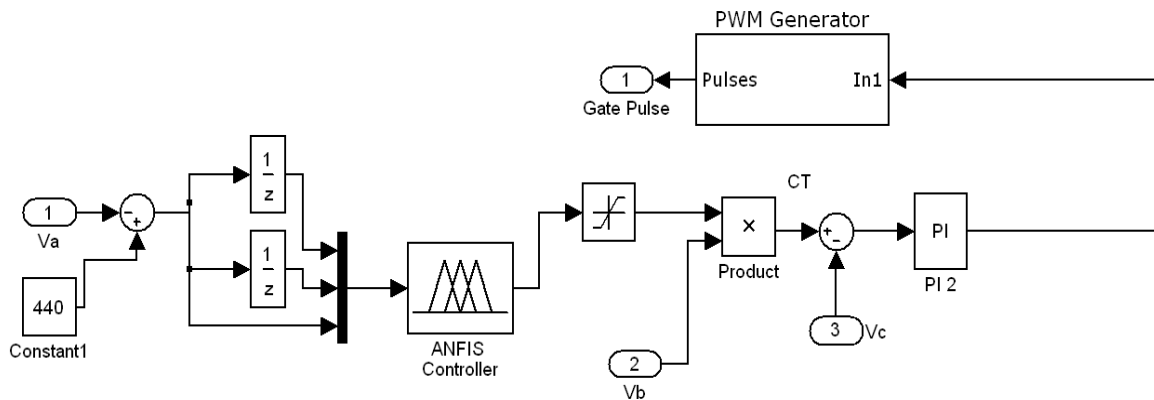

Fig. 7: Block diagram of shunt converter control topology

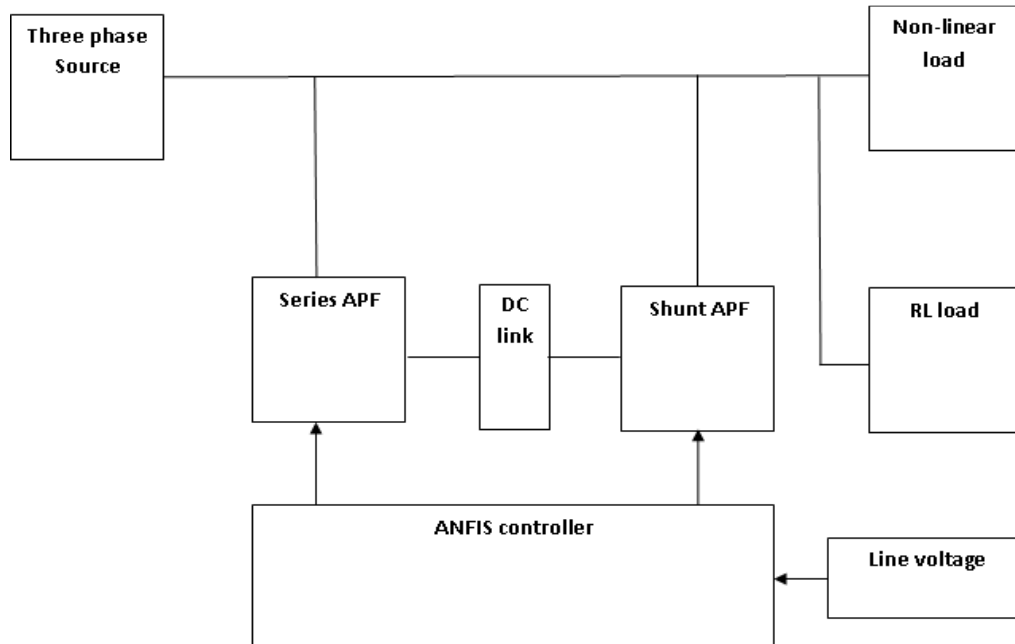

Fig. 8: Block diagram of proposed topology

to force the source currents debilitated from the network to be sinusoidal, balanced and in phase with the positive-sequence system voltages.

RESULTS AND DISCUSSION

This study proposed the ANFIS based controller of Unified Power Quality Conditioner (UPQC) for power quality improvement. The overall configuration of UPQC has been analyzed under fault condition. Here, the combination of Series APF and Shunt APF are used for controlling purpose of UPQC system. The series converter used to regulate the voltage profile and shunt converter used to regulate the current profile. The ANFIS based controller used for regulating purpose of both side converters with non linear load condition. The output of ANFIS is injected to the line by the proposed UPQC system. The block diagram of proposed configuration is shown below in Fig. 8.

The detailed model of proposed scheme has been explained by the three phase four wire UPQC topology using Adaptive Network Fuzzy Inference System (ANFIS). This system consider as the combination of fuzzy logic and artificial neural network. Here, the proposed arrangement based on fuzzy with conventional controller to improve the power quality

and stability of generation by means of achieving compensation. The simulation results are verified by MATLAB/SIMULINK platform. This corresponding SIMULINK model of proposed configuration is shown in below Fig. 9.

The above figure arrangement consists of the three phase power supply, three phase ground fault and back to back connection of converters. The reference current generation of hysteresis controller based ANFIS used to controlling the series converter. Similarly, the ANFIS based PWM pulse generation is used to controlling the shunt converter. The configuration of back to back converter is shown in below Fig. 10.

The above back to back converter arrangement having series/shunt LC filters for series APF and shunt APF respectively. Here, the series connection of capacitor in shunt converter side is used to enables the reduction in DC-Link voltage requirement and also derive power factor correction. Also, the Split range of capacitor is used for reducing range of capacitor voltage stress.

The input data of ANFIS system consider as the combination of three input and one output values. This above data is used to generate the rules for suguno method. This method producing the rules formation is applied to generate the ANFIS optimizations. The

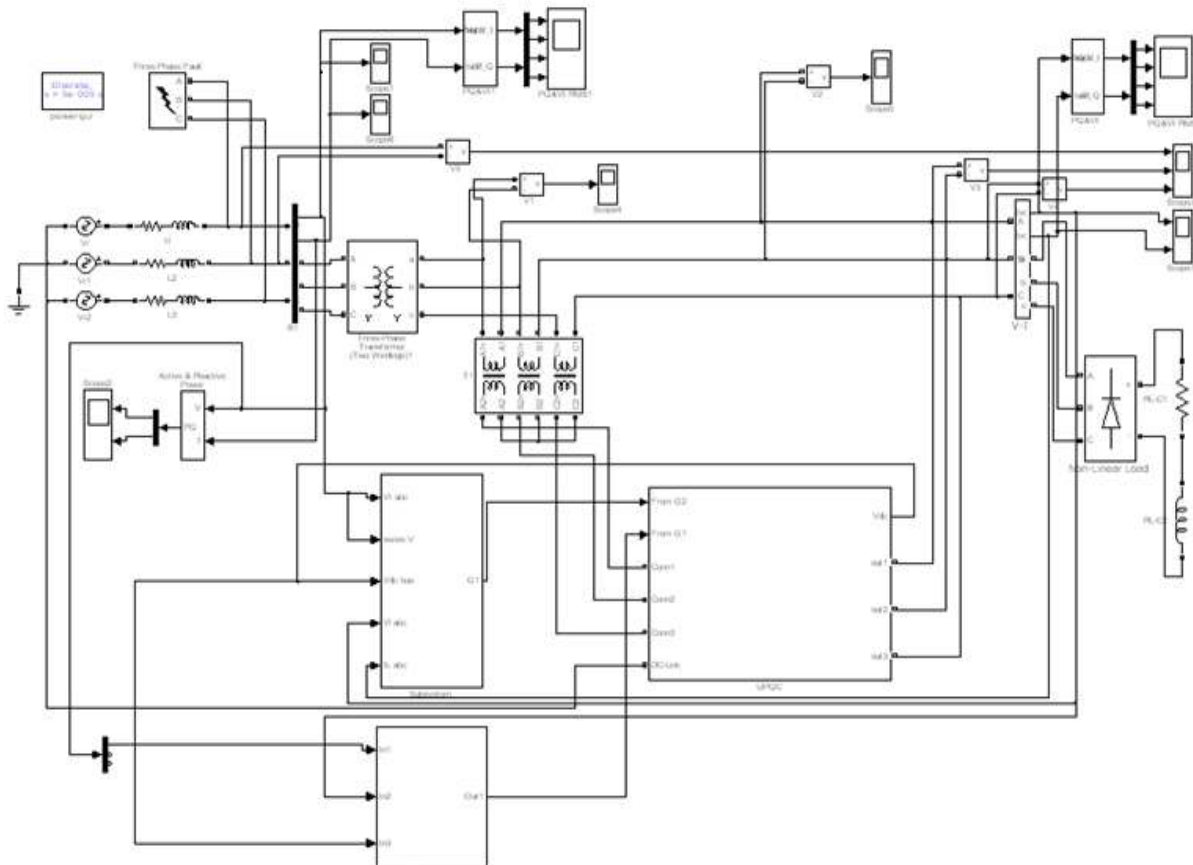

Fig. 9: Simulink model of proposed topology

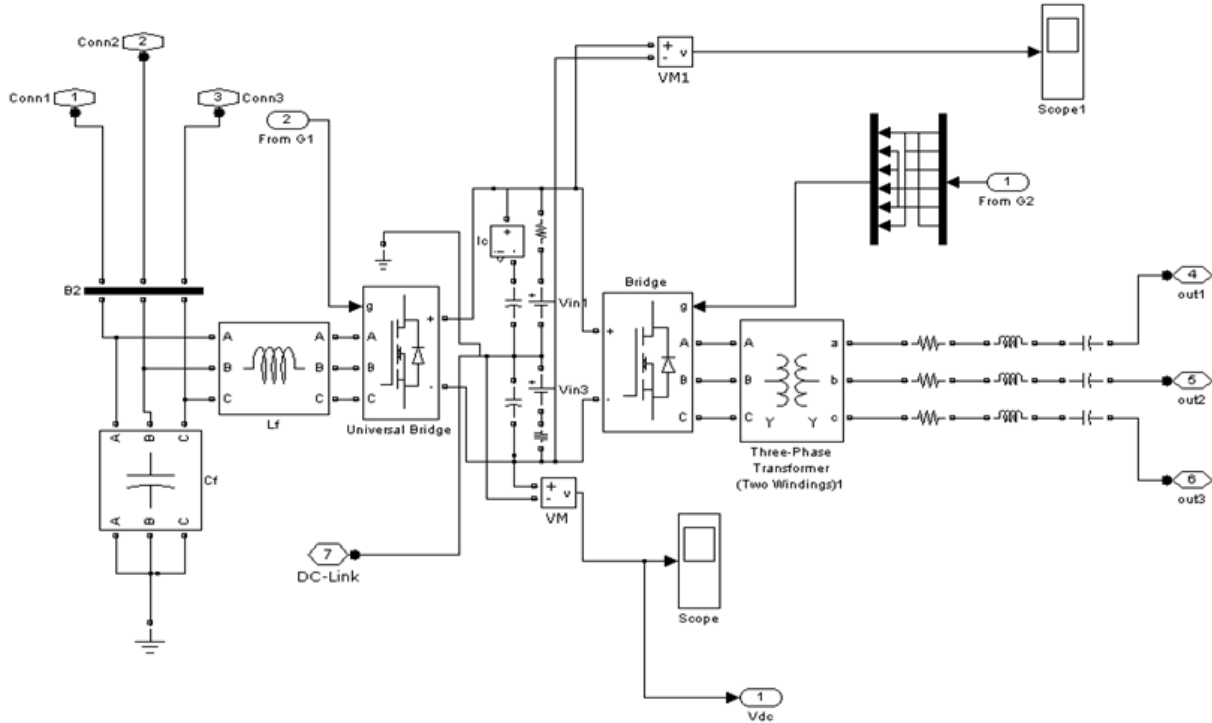

Fig. 10: Back to back converter circuit arrangement

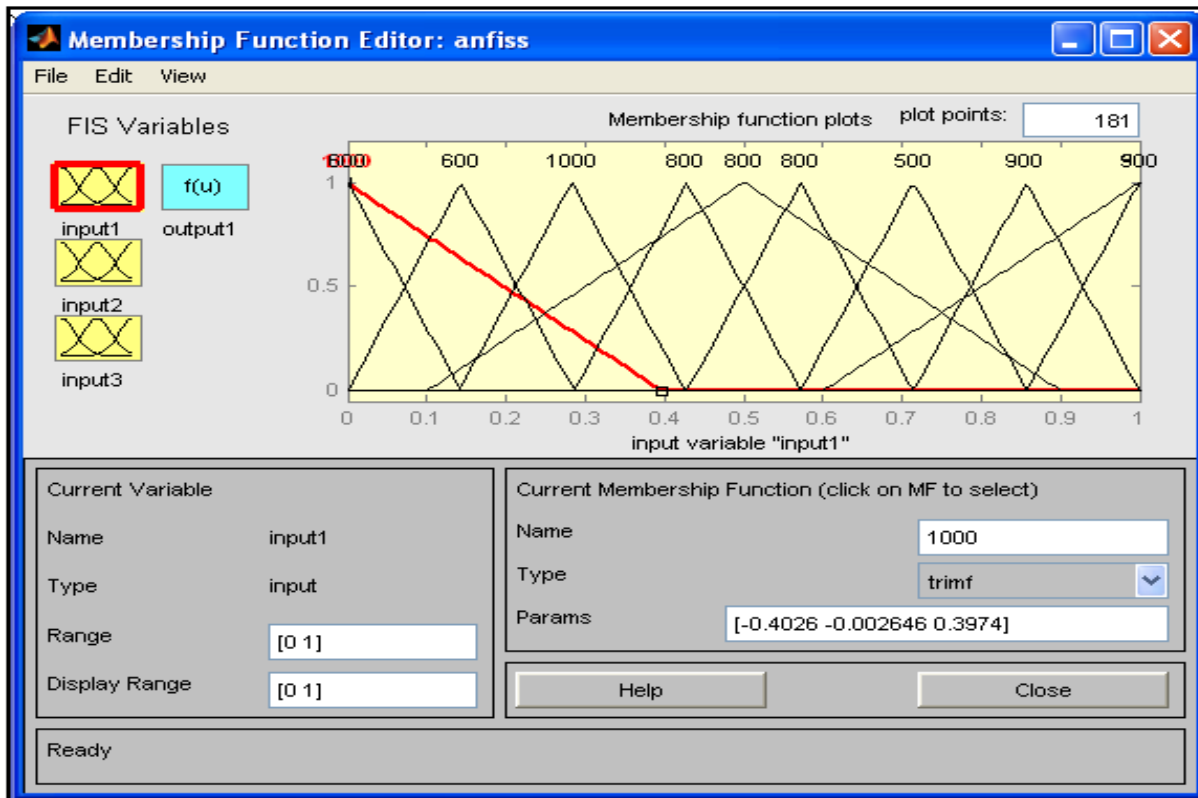

Fig. 11: Fuzzy controller based FIS variable

corresponding ANFIS implementation of simulation results are shown in Fig. 11 to 14.

The creation of sag voltage is applied for above mention the proposed topology during the 0.5 sec to 1

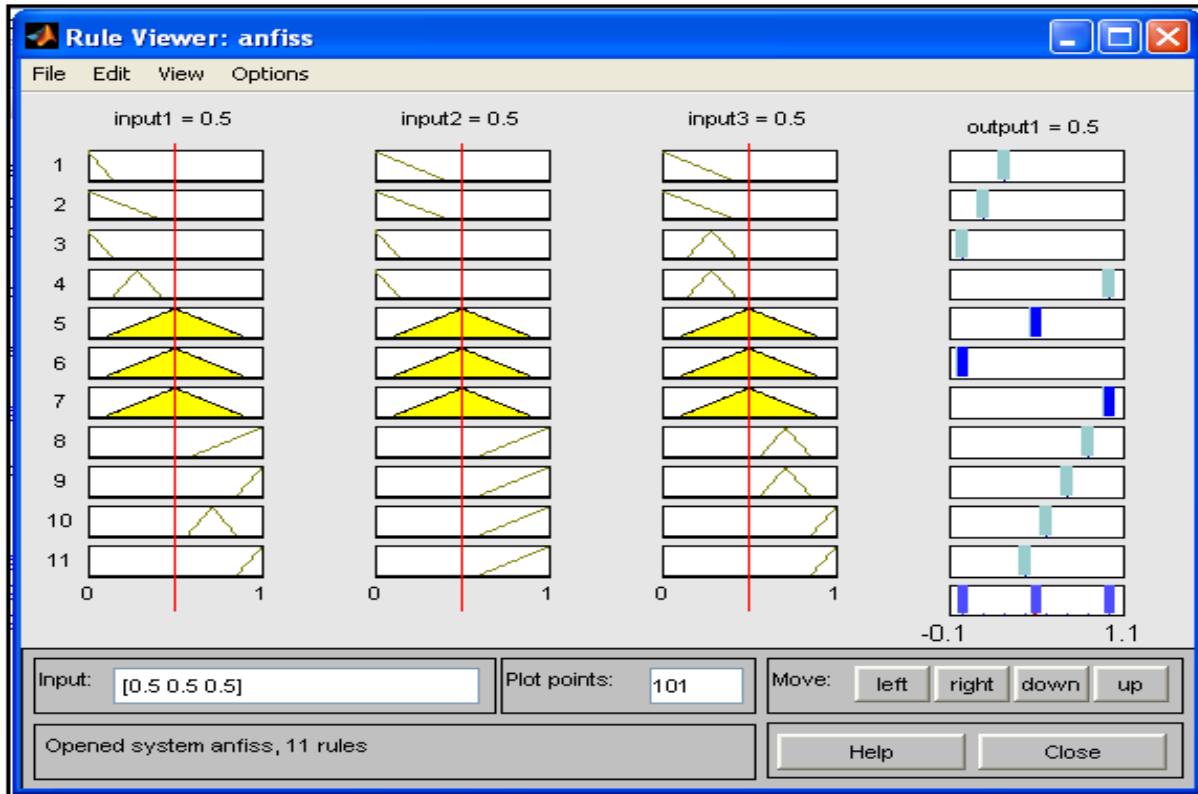

Fig. 12: Rules viewer for fuzzy control techniques

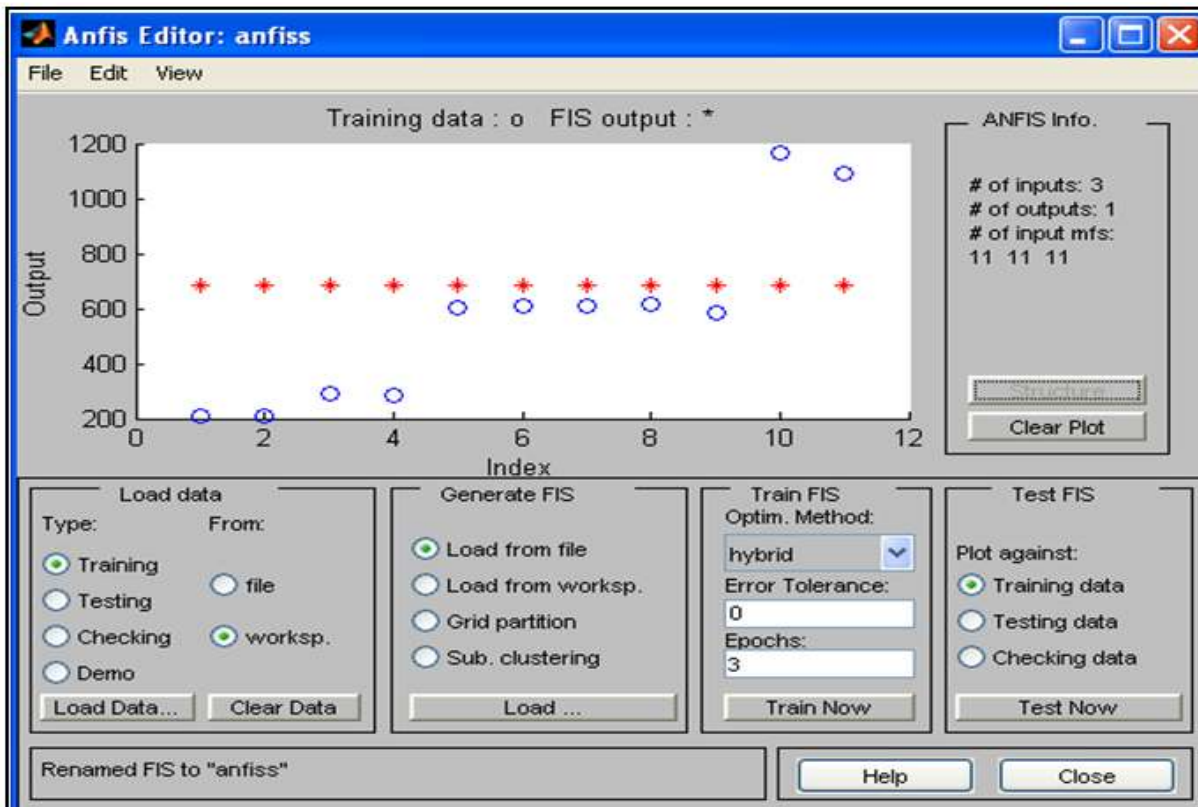

Fig. 13: GUL editor for training data

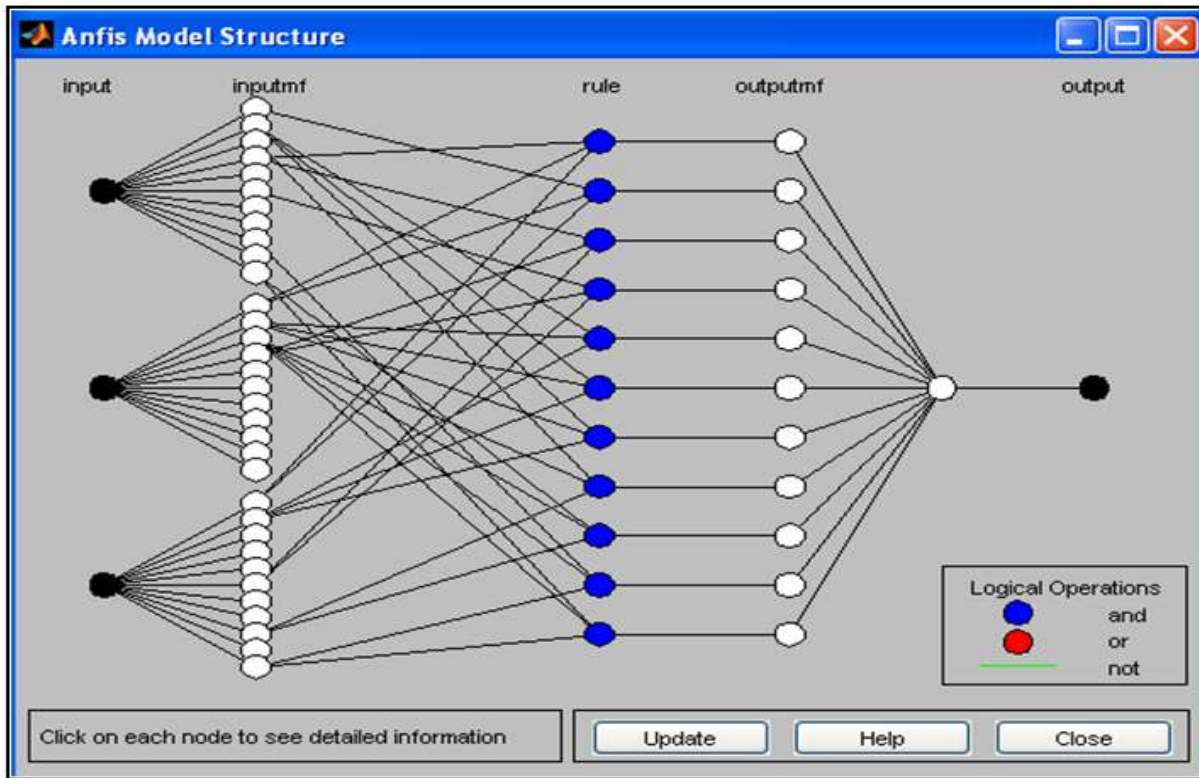

Fig. 14: Trained structure of ANFIS

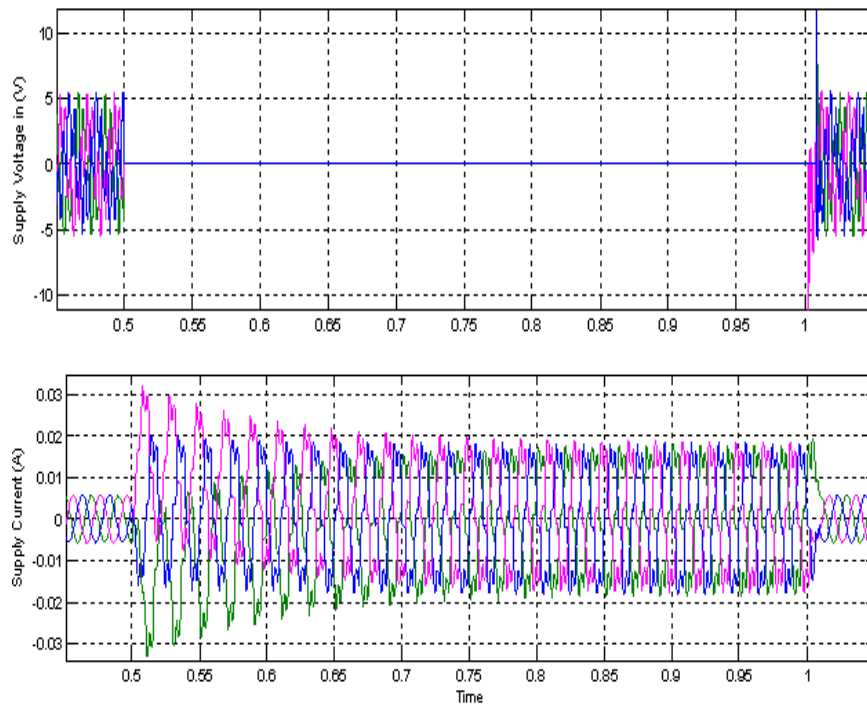

Fig. 15: Three phase sag creation waveforms

sec. Here, the voltage drops to zero at the magnitude of current increases during three phases to ground fault condition is shown in below Fig. 15 and 16.

The performance of constant and compensated power rating can be obtained by using ANFIS based hysteresis controller at series converter side and PWM

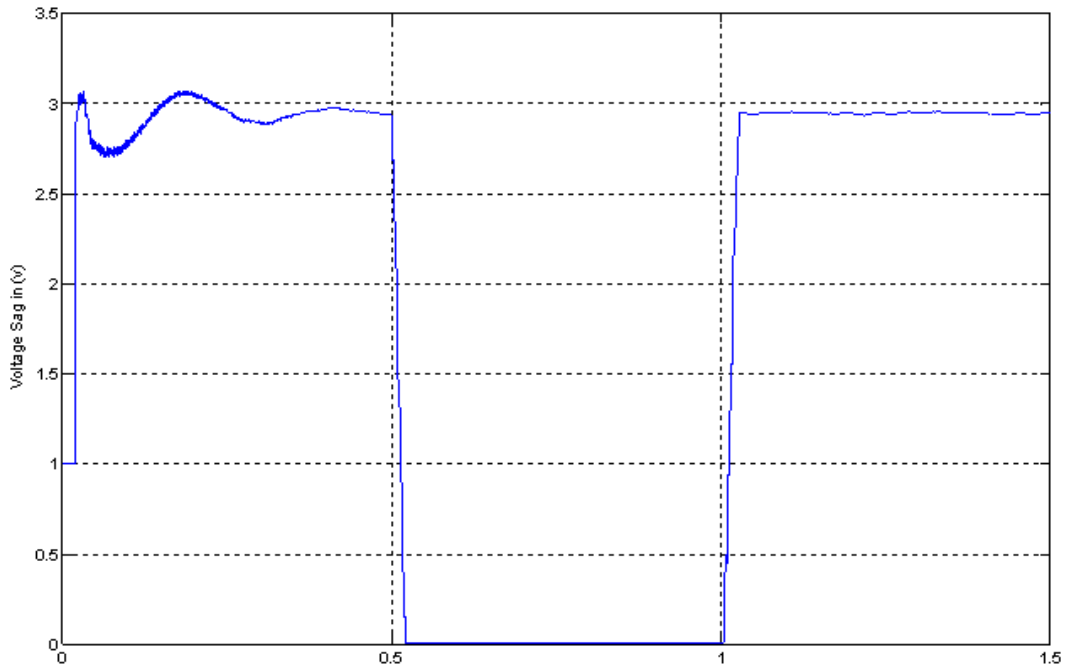

Fig. 16: Sag voltage of three phase ground fault condition

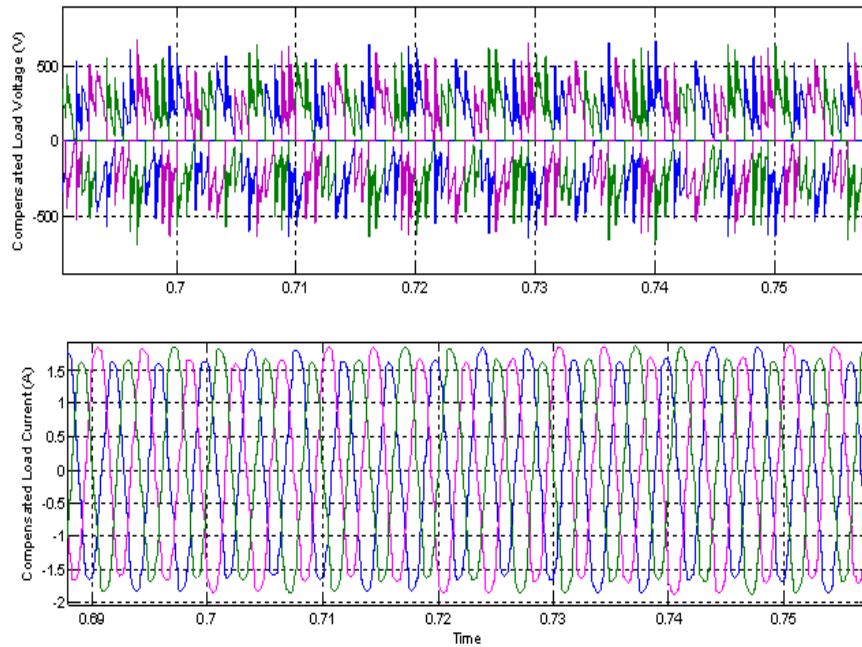

Fig. 17: Three phase sag compensation waveforms

pulse generation at shunt converter side. This corresponding sag compensation of three phase voltage and current waveforms are shown in Fig. 17 and 18.

CONCLUSION

A novel three phase four wire of UPQC configuration proposed by using the Adaptive Network

Based Fuzzy Inference System (ANFIS). This controller is used to provide the dynamic control of shunt and series converter operation of UPQC for compensation of fault condition. The configuration of Unified Power Quality Conditioner (UPQC) consists of back-to-back connection of two three-phase Active Power Filters (APF) with a common dc link. Here, one of the APF is connected in parallel with the utility called as Parallel Active Power Filter (PAPF).

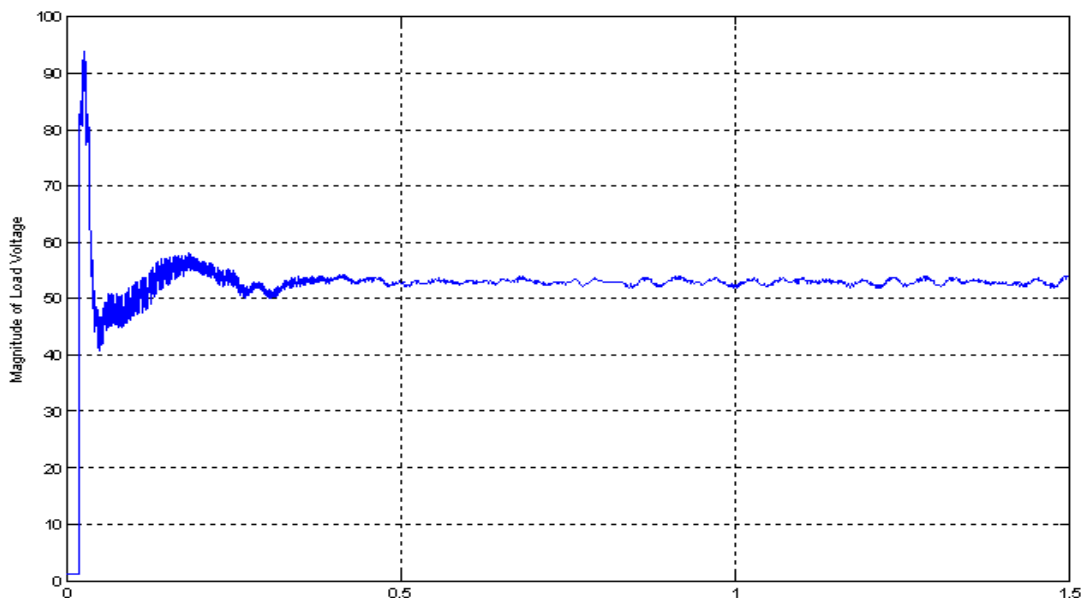

Fig. 18: Magnitude waveform for sag compensation

In this generation method has been analyzed for the reference compensating currents of PAFP and reference compensating voltage of SPAF. The proposed controller of ANFIS consists of combined operations of Fuzzy Logic (FL) and Artificial Neural Network (ANN) method. Here, the effective fault compensation can be achieved by using proposed controller over existing controller Method. The ANFIS optimization is based on the hybrid combination of least square and back propagation method. The input and output variables contains the 3 set of 11 values are taken for rules creation. The reference current generation of ANFIS hysteresis controller based series converter and ANFIS based PWM generation of shunt converter has been analyzed under fault condition. Also, in order to achieve the sinusoidal and balanced in various power quality conditions and compensation can be done easily. The simulation results have been verified by the effective compensation capability and maximum error reduction using ANFIS control.

REFERENCES

Agrawal, A., P. Agarwal and P. Jena, 2014. Compensation of voltage flicker using Unified Power Quality Conditioner (UPQC). Proceeding of the IEEE International Conference on Power Electronics, Drives and Energy Systems (PEDES, 2014), pp: 1-5.

Babu, C. and S.S. Dash, 2012. Design of Unified Power Quality Conditioner (UPQC) to improve the power quality problems by using P-Q theory. Proceeding of the International Conference on Computer Communication and Informatics (ICCCI, 2012), pp: 1-7.

Chourasia, M., S.P. Srivastava and A. Panda, 2014. Control strategy for voltage sag/swell/harmonic/flicker compensation with conventional and fuzzy controller(UPQC). Proceeding of the IEEE 6th India International Conference on Power Electronics (IICPE, 2014), pp: 1-6.

Elmitwally, A., M.S. Kandil and M. Elkateb, 2000. A fuzzy-controlled versatile system for harmonics, unbalance and voltage sag compensation. Proceeding of the IEEE Power Engineering Society Summer Meeting, 3: 1439-1444.

Esmailian, A., M. Mohseninezhad, M. Khanabadi and M. Doostizadeh, 2011. A novel technique to identify inrush current based on adaptive neuro fuzzy. Proceeding of the 10th International Conference on Environment and Electrical Engineering (EEEIC, 2011), pp: 1-4.

Ghani, R.A., A. Mohamed and H. Shareef, 2010. An approach for identifying faulty protection devices in a distribution system using ANFIS. Proceeding of IPEC Conference, pp: 368-372.

Ghosh, A. and G. Ledwich, 2001. A unified power quality conditioner (UPQC) for simultaneous voltage and current compensation. *Electr. Pow. Syst. Res.*, 59(1): 55-63.

Hembram, M. and A.K. Tudu, 2015. Mitigation of power quality problems using unified power quality conditioner (UPQC). Proceeding of the 3rd International Conference on Computer, Communication, Control and Information Technology (C3IT, 2015), pp: 1-5.

Husev, O., S. Ivanets and D. Vinnikov, 2011. Neuro-fuzzy control system for active filter with load adaptation. Proceeding of the 7th International Conference-Workshop Compatibility and Power Electronics (CPE, 2011), pp: 28-33.

- Jha, M. and S.P. Dubey, 2011. Neuro-fuzzy based controller for a shunt active power filter. Proceeding of the International Conference on Power and Energy Systems (ICPS, 2011), pp: 1-7.
- Jia, H.J., 2012. The application of adaptive neuro-fuzzy inference system in lithology identification. Proceeding of the IEEE 5th International Conference on Advanced Computational Intelligence (ICACI, 2012), pp: 966-968.
- Karanki, S.B., N. Geddada, M.K. Mishra and B.K. Kumar, 2013. A modified three-phase four-wire UPQC topology with reduced DC-link voltage rating. *IEEE T. Ind. Electron.*, 60(9): 3555-3566.
- Kumar, K.S.R. and S.V.A.R. Sastry, 2011. Application of PI, fuzzy logic and ANN in improvement of power quality using UPQC. Proceeding of the International Conference on Sustainable Energy and Intelligent Systems (SEISCON, 2011), pp: 316-319.
- Monteiro, L.F.C., J.G. Pinto, J.L. Afonso and M.D. Bellar, 2012. A three-phase four-wire unified power quality conditioner without series transformers. Proceeding of the 38th Annual Conference on IEEE Industrial Electronics Society (IECON, 2012), pp: 168-173.
- Pal, Y., A. Swarup and B. Singh, 2010. A comparative analysis of three-phase four-wire UPQC topologies. Proceeding of the Joint International Conference on Power Electronics, Drives and Energy Systems (PEDES, 2010) Power India, pp: 1-6.
- Sallama, A., M. Abbod and P. Turner, 2012. Neuro-fuzzy system for power generation quality improvements. Proceeding of the 47th International Universities Power Engineering Conference (UPEC, 2012), pp: 1-6.
- Sandhya, K., A. Jayalaxmi and M.P. Soni, 2013. Design of Unified Power Quality Conditioner (UPQC) for power quality improvement in distribution system. *IOSR J. Electr. Electron. Eng. (IOSR-JEEE)*, 4(2): 52-57.