

Research Article

Dynamic Characteristics of CUK Converter based on Sliding Mode Control

¹R. Sriranjani, ²D. Nalini and ¹S. Jayalalitha

¹School of EEE, SASTRA University, Thanjavur

²EEE Department, Mookambigai College of Engg, Pudukkottai

Abstract: In this study the output voltage is controlled by the Cuk converter using Sliding Mode Control. Here to highlight the advantages of SMC, the PI controller is used in Cuk converter to control the output voltage and it is compared with the SMC. The PI and SMC is implemented in the DC-DC converter and the study is carried in MATLAB SIMULINK. The effect of SMC on the DC-DC converter response in steady state, under line variations, load variations and different component variations will be compared with that of PI controller and results are presented.

Keywords: Cuk converter, MATLAB SIMULINK, PI controller, sliding mode control

INTRODUCTION

The DC-DC converter has non-linear components (capacitors, inductors, and resistors), the value of which changes non-linearly if the converter is disturbed or may change within a time. For the design of a DC-DC converter, a nominal voltage and load values are suggested. In practice this values may deviate. These parameters force the converter to deviate from the desired operating condition. If the parameter deviation increases, this will cause the converter not to operate in the steady state condition. Many control methods are used to control the converter and solve the problem mentioned above. Each control method has its own advantages and drawbacks due to which that particular control method appears most suitable method to control under specific conditions compared to other control methods. It is always demanded to obtain a control method that has the best performance under any conditions. Sliding mode control is one of the methods available for the analysis of non-linear systems (Su *et al.*, 2002). SMC offers an alternative way to implement a control action which exploits the inherent variable structure nature of DC-DC converters. In practice the converter switches are driven as the function of the instantaneous values of the state variables in a way that forces the system trajectory to stay on a suitable selected surface in the state space called the sliding surface. The most remarkable feature of SMC is improving the transient response of the system. In this study, transient response of the Cuk converter is studied by using PI controller and SMC control for variable input voltage and for variable load. The comparison study is carried out in Matlab simulink.

CONTROL METHODS

Feedback control is the basic mechanism through which systems, whether mechanical, electrical, or Biological, should maintain their equilibrium. Feedback control may be defined as the use of different signals that are determined by comparing the actual values of the system variables to their desired values, as a means of a control system.

Figure 1 block diagram shows the different types of controller for DC-DC converter which brings system to stable by improving by improving their time domain specification. The feedback signals are the output voltage of the load and the inductor current. The controller may be an analog or digital control.

The challenge behind this wide interest is the need of finding the most suitable control method to overcome the main problems arising and affecting the performance of the circuit. These problems are:

- Non linearity due to the non linear components in the structure of the converter
- Stability in steady state and under line and load variations

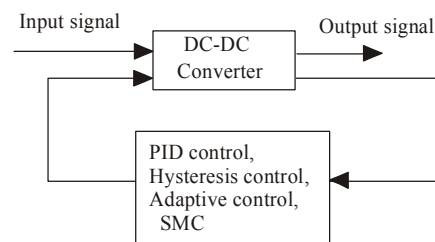

Fig. 1: Control methods-block diagram

- Achieving large signal stability often calls for reduction of the useful bandwidth which ,again affects the converter performances
- Reduction of the costs by reducing the components used in the control prototype

Non-linear control methods: The subject of non linear control deals with the analysis and design of Non-linear control systems. In the design of a non linear control, a non linear system to be controlled and certain specifications of the closed- loop system behavior are given. The task is to construct the controller so that the closed loop system meets the desired characteristics.

Several tools are available for the analysis of the non linear systems. (Mattavalli *et al.*, 1997) It may be mentioned:

- The describing function concept
- The piece wise linear approximation
- The phase plane
- The Lyapunov’s stability criterion
- Popov’s method and
- The Sliding Mode Control(SMC)

PI control: Among the control methods the PI controller is the conventional technique used to control DC-DC converters. In the proportional control, (P) control, only gain adjustment is available to improve the system performance. If a P controller cannot meet the performance specification, it should be replaced by a dynamic controller or a dynamic compensator to provide more flexibility. The lead compensator or derivative action (D) as an effect on the converter response at high frequencies and is used to improve the phase margin ϕ_m . In the derivative control a zero is added to the loop gain at frequency f_z sufficiently below the crossover frequency f_c so that the ϕ_m of the closed loop system is increased by the desired amount. The side effect of adding f_z causes the compensator gain to increase with the frequency and the compensator, to differentiate the error signal so a step must be taken to

ensure the closed loop system remains equal to unity at desired f_c . The D should contain high frequency poles f_p .

Draw backs of PI control: The voltage feedback control has good static regulation properties and tends to be stable. When reasonable values of gain are used:

- The dynamic performance is limited because a PI voltage control cannot react to disturbance until the effects have appeared in the converter output.
- As PI is applied to DC-DC converters, the operating point dependency can become a challenge. Extra ϕ_m at one operating point does not guarantee of extra ϕ_m at all point.

Sliding mode control: An approach that complies with the non-linear nature of switch mode power supplies is represented by the SMC, which is derived from the VSCS (Variable Structure Control System) theory (Venkataramanan *et al.*, 1985).

This control method offers several advantages over the other control methods which are:

- Stability even for large line and load variations
- Robustness
- Good dynamic response
- Simple implementation

Variable Structure Systems (VSS) are systems the physical structure of which is changed intentionally during time with respect to the structure control law. The instances at which the changing of the structure occurs are determined by the current state of the system. The SMC provides alternative way to implement a control action, which exploits the inherent variable structure nature of DC-DC converter. In practice, “The converter switches are driven as a function of the instantaneous values of the state variables in a way that forces the system trajectory to stay on a suitable selected surface in the same space called the sliding surface”.

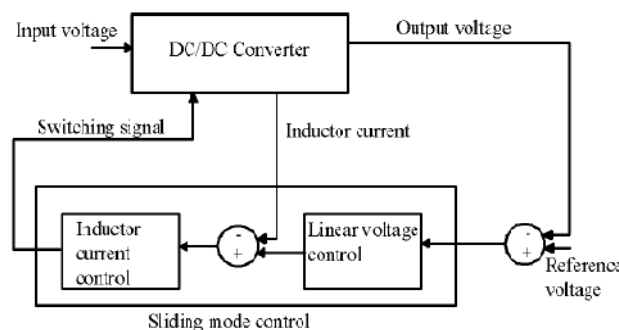

Fig. 2: Block diagram of sliding mode control of DC-DC converters

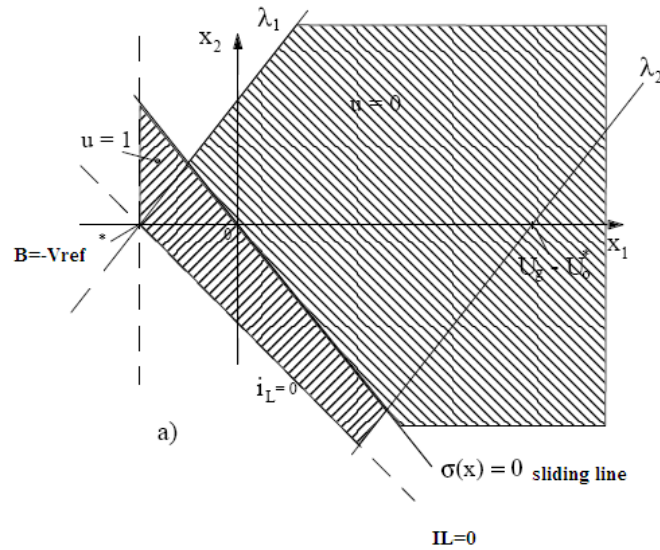

Fig. 3: Sliding mode region of existence

Sliding mode control for dc-dc converter: One of the most important features of the sliding mode control regime in the VSS is the ability to achieve response that is independent of the system parameters. From this point of view, the DC-DC converter is particularly suitable for the application of the SMC, because of its controllable state “the system is controllable if every state variable can be affected by an input signal”. The output voltage and its derivative are both continuous and accessible for measurement. For DC-DC converters used in practice, the motion rate of the current is much faster than the motion rate of the output voltage. The control problem can be solved by using cascaded control structure with two control loops: an inner current control loop, and an outer voltage control loop. The combined loop represents the SMC. The voltage control is usually realized with standard linear control techniques, while the current control is implemented using either PWM or hysteresis control. Here the sliding mode control approach is used for the control of inductor current. Figure 2 shows the general block diagram of the DC-DC converter with SMC. The main problem of this control method is that there is no direct way to measure the gain of linear part, which can be considered as a drawback

Sliding mode region of existence: Figure 3 Shows the sliding mode region of existence. Sliding mode surface equation is $\lambda x_1 + x_2 = 0$. $\lambda = -x_2/x_1$ which represents the negative slope. Then only the system will be stable. If it is positive slope means the system will go to unstable, the trajectory does not reach its target (Malesani *et al.*, 1992; Mattavelli *et al.*, 1993).

Chattering: The chattering phenomenon is understood to be an oscillatory motion in the neighborhood of the sliding manifold (Mattavelli *et al.*, 1993). Possible mechanisms that cause chattering include non-idealities of the switching devices for control realization or the

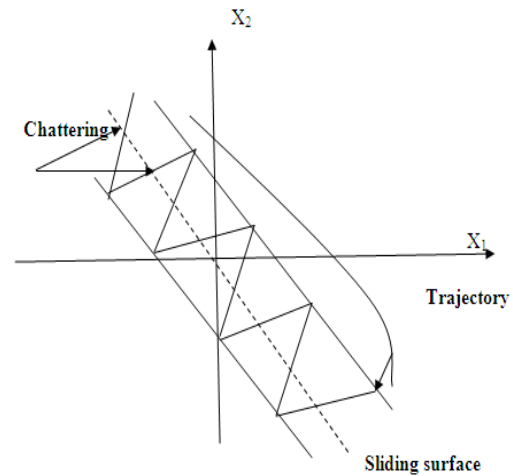

Fig. 4: Chattering

existence of parasitic dynamics in series with the plant. The chattering phenomenon is unavoidable in the real application. An alternative approach suggestion is a continuous approximation of discontinuous control. In addition to that, continuous approximation is unpractical in switching converters related systems, in which the On/Off of the switch is in particular way of pattern. Figure 4 shows the chattering phenomenon of sliding mode control.

Performance of the system: The proposed system improves the domain specification of the output voltage of the Cuk converter. Table 1 shows the result analysis of the PI controller and the SMC. Table 2 shows that the SMC improves the transient response of the Cuk converter when the variation in voltage and load occurs. Figure 5 and 6. Shows the control strategy of PI and SMC. Figure 7 and 8 shows that the waveform of the

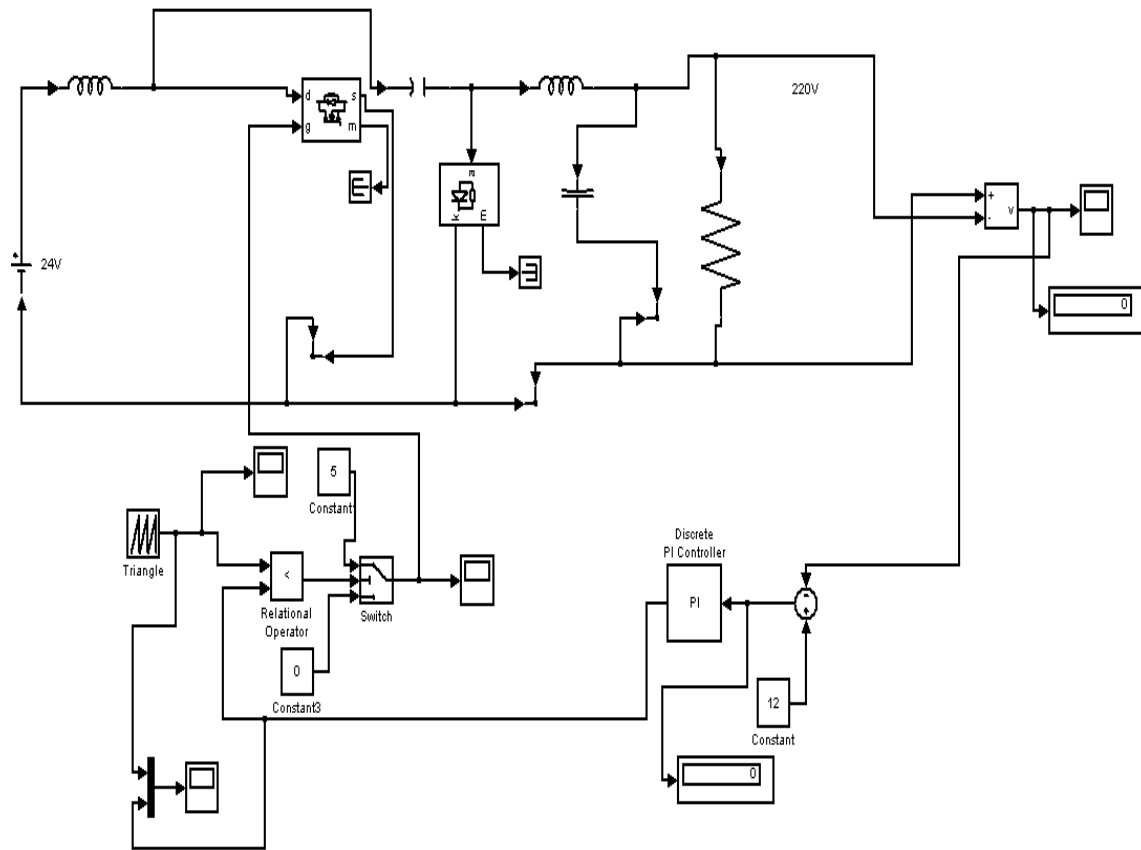

Fig. 5: PI controller

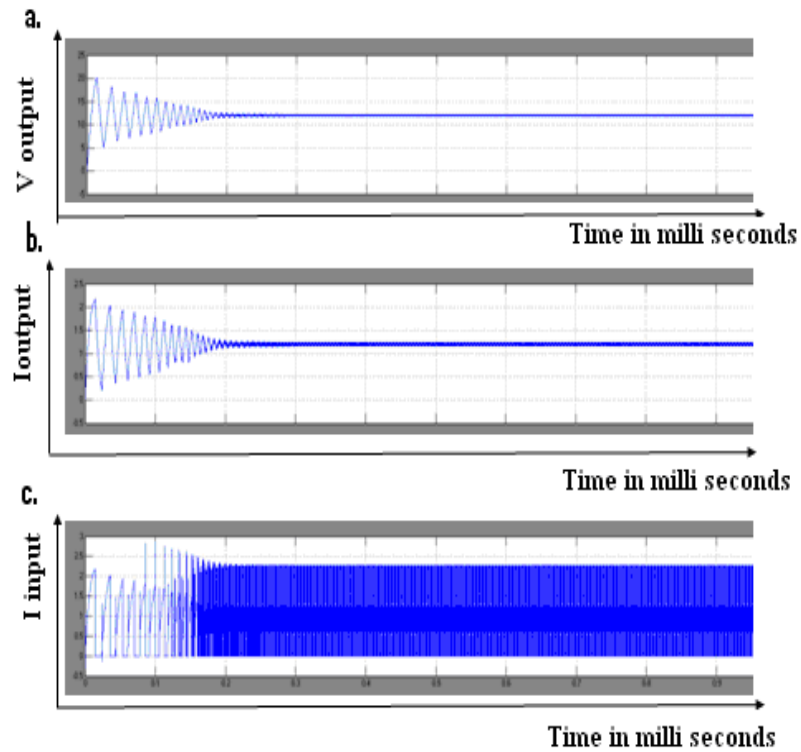

Fig. 6: (a) output voltage, (b) output current, (c) input current waveforms of PI controller

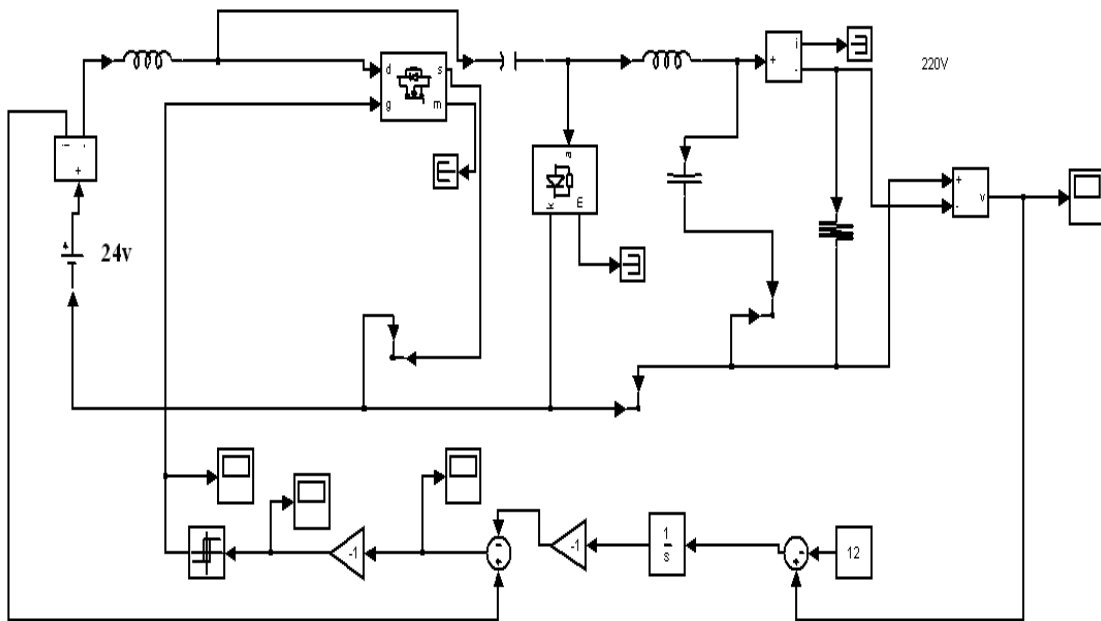

Fig.7: SMC controller

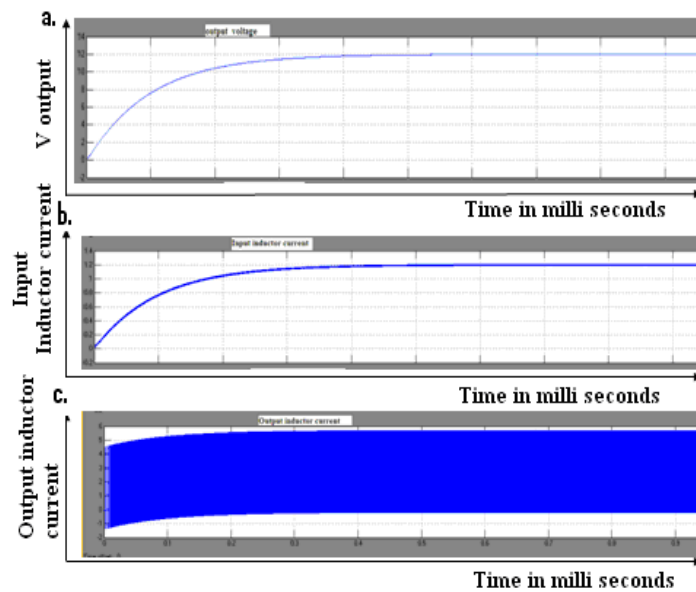

Fig. 8: (a) output voltage, (b) output current, (c) input current waveforms of SMC

Table 1: Comparison of output voltages

	PI		SMC	
	Peak value	t_s	Peak value	t_s
Control region				
Transient region	5.5 v	4ms	4.5 v	3 ms
Line variation (24V to 30V)	0.6 v	2ms	0	0
Line variation (24V to 18V)	Unstable	Unstable	0	15 ms
Load variation (10 Ω to 1 Ω)	0	1ms	0	42 ms
Steady state region	0.005v ripple	-	0.005v ripple	

Table 2: Comparison of inductor currents

	PI		SMC	
	Peak value	t_s	Peak value	t_s
Control region				
Transient region	33.8A	4 ms	1.5A	30 ms
Line variation(24 V to 30 V)	2.3A	2 ms	0	0
Line variation (24V to 18V)	Unstable	Unstable	0	7 ms
Load variation (10 Ω to 1 Ω)	1A	0	0	60 ms
Steady state region	1A ripple		1A ripple	

t_s -settling time in sec

Cuk converter with PI and SMC control. In PI control, the converter operates as a underdamped system

whereas in SMC; it operates as a critically damped system.

CONCLUSION

In steady state region both the control methods give the same performance. In Transient region voltage and current overshoot are very low in SMC. In line variation SMC is insensitive to the input variations. For wide range of load variation SMC is more stable when compare to PI controller. SMC provides several advantages over other control methods: Robustness, stability for even very large line and load variations, good dynamic response and simple implementation.

REFERENCES

- Malesani, L., R.G. Spiazzi and P. Tenti, 1992. Performance optimization of cuk converters by sliding mode control. *IEEE T. Power Electr.*, 10(3): 302-309.
- Mattavalli, P., L. Rosetto and G. Spiazzi, 1997. Small-signal analysis of DC-DC converters with sliding mode control. *IEEE T. Power Electr.*, 12: 96-102.
- Mattavelli, P., L. Rossetto, G. Spiazzi and P. Tenti, 1993. Sliding mode control of SEPIC converters. *Proceeding of European Space Power Conference (ESPC)*. Graz, pp: 173-178.
- Su, J.H, J.J. Chen and D.S. Wu, 2002. Learning feedback controller design of switching converters via mat lab/simulink. *IEEE T. Educ.*, 45: 307-315.
- Venkataramanan, R., A. Sabanovic and S. Cuk, 1985. Sliding-mode control of DC-to-DC converters. *Proceeding of International Conference on Industrial Electronics, Control and Instrumentation (IECON '85)*. (Cat. No. 85CH2 160-0), 1: 251-258.