

Research Article

Reliability Analysis of Phased Mission Systems by Considering the Concept of Sensitivity Analysis, Uncertainty Analysis and Common Cause Failure Analysis using the GO-FLOW Methodology

Muhammad Hashim, Yoshikawa Hidekazu, Msuoka Takeshi and Yang Ming
College of Nuclear Science and Technology, Harbin Engineering University, 145-1 Nantong Street,
Nangang District, Heilongjiang, Harbin, 150001, P.R. China

Abstract: The reliability is the probability that a device will perform its required function under stated conditions for a specified period of time. The Common Cause Failure (CCFs) is the multiple failures and has long been recognized (U.S. NRC, 1975) as an important issue in the Probabilistic Safety Assessment (PSA) and uncertainty and sensitivity analysis has the important information for the evaluation of system reliability. In this study, two cases has been considered, in the first case, author have made the analysis of reliability of PWR safety system by GO-FLOW methodology alternatively to Fault Tree Analysis and Even Tree because it is success-oriented system analysis technique and comparatively easy to conduct the reliability analysis of the complex system. In the second case, sensitivity analysis has been made in order to prioritize the important parameters which have largest contribution to system reliability and also for common cause failure analysis and uncertainty analysis. For an example of phased mission system, PWR containment spray system has been considered.

Keywords: Common cause failure analysis, containment spray system, dynamical reliability analysis, GO-FLOW methodology, montecarlo simulation, phased mission system, PWR, uncertainty analysis

INTRODUCTION

The operation of mission encountered in aerospace, chemical, communication networks, electronics, transportation, nuclear and many other applications involves several different tasks or phases that must be accomplished in sequence (Ma and Trivedi, 1999). The systems used in missions are usually called Phased Mission Systems (PMS). In the reliability analysis, most reliability techniques and tools generally assume the systems as being analyzed perform a single phased mission but with the increased use of automation in above industries, the Phased-Mission System (PMS) analysis is being recognized as an appropriate reliability analysis method for a large number of problems (Liudong, 2007). The reliability is the probability that a device will perform its required function under stated conditions for a specified period of time. It is often measured as a probability of failure or a measure of availability (Hashim *et al.*, 2012). The dynamic reliability methods were developed in the late 1980s, early 1990s to explicitly handle the influence of time, process dynamics and human action, on system operations and failures and accidental scenarios (Florent *et al.*, 2011). The reliability of a PMS is the probability that the mission successfully achieves all the submission objective in each phase.

The dynamic reliability problems are challenging to solve because they are inherently very high dimensional while still involving the small failure probabilities that are a common characteristic of engineering reliability problems (Ching *et al.*, 2005). To solve the dynamic problem, the first dynamic approach was denoted Dynamic Logical Analytical Methodology (DYLAM) (Amenda and Reina, 1984) and to simulated all the possible event sequences it uses the time discretization according to the evolution of process variables. There are also other several methods which have been emerged for dynamical reliability modeling and are not discussed in this study.

The dynamical reliability explicitly handles the interactions between the stochastic behavior of system components and the deterministic behavior of process variables. The dynamic reliability provides a more efficient and realistic way to perform probabilistic risk assessment but the static approaches, its industrial level applications are still limited (Florent *et al.*, 2011). The author of this study has considered the GO-FLOW methodology (Matsuoka and Kobayashi, 1988) for evaluating the dynamical reliability for phased mission system by considering the sensitivity analysis, uncertainties and Common Cause Failure analysis (CCFs). The PWR containment spray system has been taken as an example of phased mission system. The

Corresponding Author: Muhammad Hashim, College of Nuclear Science and Technology, Harbin Engineering University, 145-1 Nantong Street, Nangang District, Heilongjiang, Harbin, 150001, P.R. China, Tel.: +8615146635655

This work is licensed under a Creative Commons Attribution 4.0 International License (URL: <http://creativecommons.org/licenses/by/4.0/>).

GO-FLOW methodology is success-oriented system analysis technique and is capable of evaluating the reliability and availability of complex system. The GO-FLOW methodology possesses the following significant features.

- The GO-FLOW chart corresponds to the physical layout of a system and is easy to construct and validate
- Alterations and updates of a GO-FLOW chart are easily made
- The GO-FLOW chart contains all possible system operational states
- The analysis is performed by one GO-FLOW chart and one computer run

The sensitivity analysis is made by GO-FLOW methodology to priorities the several important parameters to dynamical reliability. In this study two cases are considered such as:

Case 1: Dynamic reliability analysis of Phased mission system

Case 2: Sensitivity analysis in order to select most sensitive parameters for uncertainty analysis and common cause analysis.

DESCRIPTION OF PHASED MISSION SYSTEMS AND GO-FLOW METHODOLOGY

The Phased Mission System (PMS) is subject to multiple, consecutive and non-overlapping phases (time periods) of operation, in which the system configuration, failure criteria and components behavior (e.g., failure rate) may be different (Liudong and Joanne, 1999). In phased mission problem, system operated in several phases and system must operate successfully during each of the phases for complete execution of mission.

The example of the phased mission problem includes an aircraft flight that involves take-off, ascent, level flight, descent and landing and also many military operations for both aircraft and ships. During the execution of the task, the configuration of system is altered such that the failure logic model or system failure characteristics may change to accomplish a different objective.

The phase number, time interval, system configuration, tasks to be undertaken, performance measure of interest and maintenance policy can be used for the expression of mission. This type of mission can be epitomized as a sequence of discrete events required to accomplish a task (La Band and Andrew, 2004). The reliability of a PMS is, in principle, the probability that the mission successfully achieves all the submission objectives in each phase. The condition of components may be critical for one particular phase and transition from one phase to another is the critical event leading to

mission failure. The failure of the components can occur at any point during the mission.

In light of such considerations, a method to express how the combinations of component failures (basic events) can occur during the phases throughout the mission and cause system failure is required (La Band and Andrew, 2004). These failure events then require quantification to enable the likelihood and frequency of mission failure to be determined. For the solution of a phased mission problem, there are techniques that have previously been implemented such as Fault Tree Analysis (FTA), Markov Analysis and Simulation as well as new technique as GO-FLOW methodology.

The Fault Tree Analysis (FTA) is a top-down, deductive failure analysis in which an undesired state of a system is analyzed using Boolean logic to combine the series of lower level events. The FTA has some difficulties in phased mission problem, such as; it is difficult to evaluate the reliability of the machine systems which will change the operation mode with time.

Mindful of these difficulties the author has considered the GO-FLOW methodology for analyzing the dynamical reliability of PWR containment spray system that undergoes phased missions. Owing to the fact that the GO-FLOW can easily make logic for each phase freely, logic models in different phases can mutually use the same component's failure. The probability of the system successively operating in the series of phase is automatically calculated by carefully considering the dependencies with the aids of phased mission operator (type 40). Automatic consideration of components' dependencies is the feature of GO-FLOW methodology.

There are two phases in PWR containment spray system, that is, injection phase and recirculation phase. In GO-FLOW reliability analysis, the results of the analysis are the system failure modes in each phase, the failure probability and the total mission unreliability. The success of the mission depends on the performance of the PWR containment spray system's components used in each phase and the probability of this success is referred to as the mission reliability.

CONSIDERATION OF COMMON CAUSE FAILURE AND UNCERTAINTY ANALYSIS

Overview of common cause failure and uncertainty analysis: A Common Cause Failure (CCFs) is the simultaneous failure of multiple components due to Common Cause (CC). CCFs can exist in most systems with redundant components and can have an important contribution to system unreliability (Matsuoka and Kobayashi, 1997). CCF have long been recognized (U.S. NRC, 1975) as an important issue in the Probabilistic Safety Assessment (PSA) for nuclear power plants (IAEA (International Atomic Energy Agency, 1992).

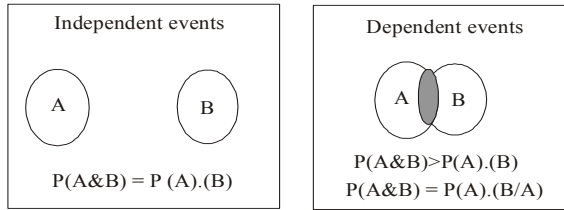

Fig. 1: Independent and dependent events

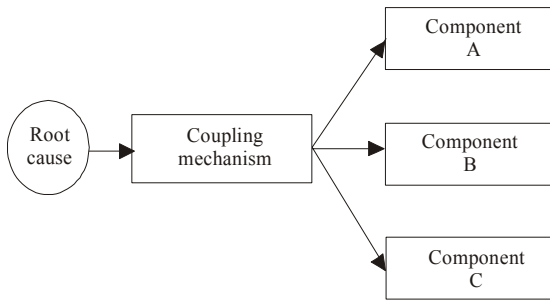

Fig. 2: Physical element of a dependent event

The CCF events included in plant logic models represent those inter component dependencies which are potentially significant and whose mechanisms are not explicitly represented in the logic model (event trees and fault trees) of the plant (IAEA (International Atomic Energy Agency), 1992). An event in which a component state occurs, causally unrelated to any other component state is considered as an independent event and if an event is not independent, it is defined as a dependent event. The dependent and independent events are shown in Fig. 1.

The common cause event are the subset of dependent events in which two or more component fault states exits at the same time, or in a short time interval and are direct result of a shared cause. The physical elements of a dependent event are shown in Fig. 2.

The events that causally occurred at some distinct but possibly unknown point in time are called root cause. There are four general types of root causes, that are:

- Hardware
- Human
- Environmental
- External

The way to explain how a root cause propagates to involve multiple equipment items; e.g., components, is called the coupling mechanism.

There are three broad categories of coupling mechanisms

- Functional equipment's (connected equipment and nonconnected equipment)

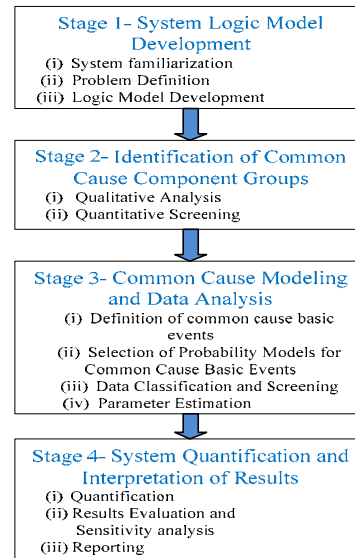

Fig. 3: Procedural framework for common cause failure analysis

- Spatial couplings (spatial proximity, linked equipment)
- Human couplings

These functional dependencies are normally modeled explicitly in systems models without the special common cause events' model. The special common cause events models are Beta factor, Binomial failure rate, Multiple Greek Letter, basic parameter and common load etc. The reliability of the system with high redundancy is degraded due to CCFs and when the reliability of Phased Mission System (PMS) is considered, CCF can complicate the analysis. The procedural framework for the analysis of common cause consists of four major stages each of which contains a number of steps. The procedural framework of common cause failure analysis is shown in Fig. 3 (IAEA (International Atomic Energy Agency), 1992).

Stage 1: Stage 1 is prerequisite for common cause failure analysis and is carried out in accordance with the PSA procedures (IAEA (International Atomic Energy Agency), 1992). It is important that categories of dependencies, such as physical and human interactions, Common Cause Initiators (CCIs) and functional which are modeled explicitly

Stage 2: Focuses on the identification of Common Cause Components (CCC) and on screening process. It is critical for the definition of the scope of the detailed analysis

Stage 3: The incorporation of common cause events in the logic model is achieved by a straightforward modification of its structure. The models can be selected for quantification

of CCF contributions and provide the engineering argument for analysis and manipulation of data

Stage 4: Synthesizes the key output leading to quantification of system failure probability. Provide engineering argument for interpretation of results

Uncertainty analysis investigates the uncertainty of variables that used in decision-making problems in which observations and models represent the knowledge base. Uncertainty analysis aims to make a technical contribution to decision-making through the quantification of uncertainties in the relevant variables. In the physical experiments, the uncertainty analysis deals with assessing the uncertainty in a measurement and in numerical experiments and modeling uncertainty analysis draws upon a number of techniques for determining the reliability of model predictions, accounting for various sources of uncertainty in model input and design. A related field is sensitivity analysis ([http://en.wikipedia.org/wiki/Uncertainty analysis](http://en.wikipedia.org/wiki/Uncertainty_analysis) (Accessed on: June 4, 2012)).

There are two broad categories of uncertainties may be defined as aleatory uncertainty (having to do with chance) and epistemic uncertainty (having to do with knowledge). Aleatory uncertainty is the inherent variation in the physical system; it is stochastic, irreducible uncertainty. Epistemic uncertainty is the scientific uncertainty in the model of the process. It is due to limited data and knowledge of the quantities or processes identified with the system. The epistemic uncertainty is characterized by alternative models (Pinder *et al.*, 2006).

Epistemic uncertainties may be further divided into parameter uncertainties and model uncertainties. In present study, epistemic uncertainty is considered in reliability analysis.

Procedure of common cause failure analysis by GO-FLOW methodology: The identification of the possible common cause failures is the important task in the treatment of CCFs. The CCFs can be modeled explicitly if the cause-effect logic is clear and for the CCFs that are not modeled explicitly, the parametric common cause models have to be applied (Matsuoka and Kobayashi, 1997). In the CCFs, there are more than one common cause and many possible combinations of components failures for a specific common cause. The analysis becomes impractical if all the common causes are treated at the same time. Therefore each common cause is separately evaluated and the total system unavailability is obtained by summing up contribution from each CCF.

If there are two basic events A and B (failure events) which are subjected to common cause. A system failure S, is expressed in the following general

Boolean algebraic equation:

$$S(A, B) = (AE + BF + ABG).H + K \quad (1)$$

From E to K are some Boolean algebraic terms not suffered by common cause. The basic events are decomposed into independent events and a common cause failure as follows:

$$A = A_i + C_{AB}, B = B_i + C_{AB} \quad (2)$$

Substitute the above relations into Eq. (1) and rearrange it:

$$S(A, B) = S(A_i, B_i) + C_{AB}(E + F + G).H \quad (3)$$

where, S(A_i, B_i) means that basic events A and B are replaced by independent failure events A_i and B_i, respectively

In the expression of failure probability the above equation can be written as:

$$P\{S(A, B)\} = P\{S(A_i, B_i)\} + P(C_{AB}) \cdot [P\{S(1, 1)\} - P\{S(0, 0)\}] \quad (4)$$

where, P{S(1,1)} and P{S(0,0)}, means the system failure probability when occurrence probabilities of basic events A and B are replaced by 1.0 and 0.0, respectively. The first term is the contribution from the independent events and the second term is from the common cause event C_{AB}.

The general formula is obtained as the next equation. Where, the summations are performed on the common cause kinds C_i number of suffered components N and the possible combination of m components (Matsuoka and Kobayashi, 1997).

As there are two basic types of uncertainty: parameter value uncertainty and modeling uncertainty. The GO-FLOW handles the parameter value uncertainty. The distribution of a system failure probability is calculated by combining values selected by sampling from the probability distribution for all the basic events (Matsuoka, 2010).

Uncertainty analysis by GO-FLOW methodology: The uncertainty analysis procedure consists of two steps:

- The Minimal Cut Sets (MCS) are obtained for specific signal lines. As the GO-FLOW is a success-oriented system analysis technique and system states expressed in success probability are converted into the expression in the failure probability and the MCSs are obtained.
- The distributions of failure probabilities are assigned for the basic events in the MCSs and the distribution of a system failure probability is

obtained with the Monte Carlo Simulation. The distributions which can be assigned to the basic events are as follows, the Normal Distribution, Log-normal distribution, Homogeneous, Log-homogeneous, Gamma, Binomial, Weibull, Beta and Histogram distributions. From the uncertainty analysis results, the following terms can be obtained; the values median, mean, error factor, 90% ranges of uncertainty, cumulative probability distribution and probability density distributions. The time variation of uncertainty distribution and failure probability distribution at any part of a system can be obtained (Matsuoka, 2010).

CASE 1: EXAMPLE PRACTICE OF PHASED MISSION SYSTEM

Function and structure of PWR containment spray system during the large break LOCA: The PWR containment spray system has been taken as an example of dynamic phased mission system. The configuration of PWR containment spray system employed is illustrated in Fig. 4. Containment Spray System has the function to decrease the containment pressure during the large Loss Of Coolant Accident (LOCA) to attain the design pressure of containment vessel (atmospheric pressure). The pressure transient during LOCA is analyzed for the maximum blow down energy of the reactor coolant system at the same time.

Containment spray system traps radioactive inorganic iodine to wash down into the containment sump by spraying the borated cooling water (JNESO, 2005).

Sodium Hydroxide (NaOH) solution of about 30% concentration is added from Spray Additive Tank

(SAT). The containment spray system is designed to have redundancy according to single criteria. During the large break LOCA if there is no offsite power, then the necessary electric power is supplied by Diesel Generators and it can perform the specified safety function. In the containment spray system there is test line which is designed to allow periodical tests and inspections to verify the operability and integrity depending on the importance of safety.

In Fig. 4, containment spray system consist of Containment Spray Pump (CSP), Containment Spray Heat Exchangers (CSHEX), Refueling Water Storage Tank (RWST), Spray Additive Tank (SAT), Containment Recirculation Sump (CRS) etc. CSHEXs are cooled by Component of Cooling water. RWST is designed to provide the borated water which is pressurized with nitrogen. The redundant spray Pumps and Heat Exchangers of 100% capacity are installed. The NaOH solution makes water slightly alkali to enhance absorption of radioactive iodine and to prevent corrosion of the vessel during long-term cooling after the accident. It can minimize the transpiration of radioactive iodine from the recirculation sump water. When the containment pressure is increased during the LOCA then containment high pressure signal is actuated and transmitted to containment spray system, CSHEXs outlet valve is opened, CSP is started, SAT injection valve is opened and the borated cooling water in RWST is sprayed into the containment Vessel through the Spray nozzles attached on the spray headers (injection mode; phase 1). When the water level in RWST becomes low until a certain value, then the water source is switched to the CRS and after cooling, the recirculation water by CSHEXs, the water will be

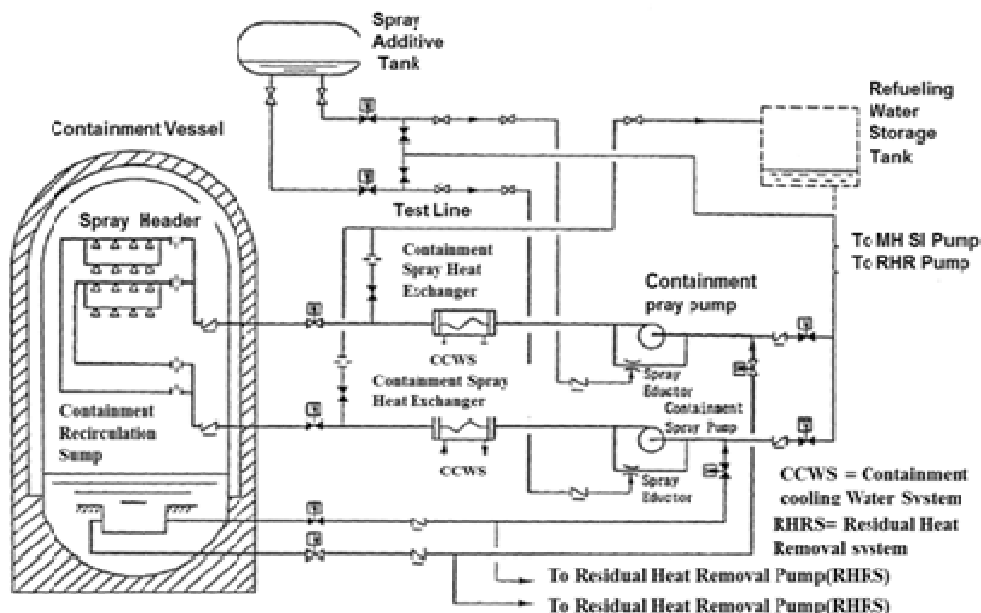

Fig. 4: Containment spray system of PWR plant

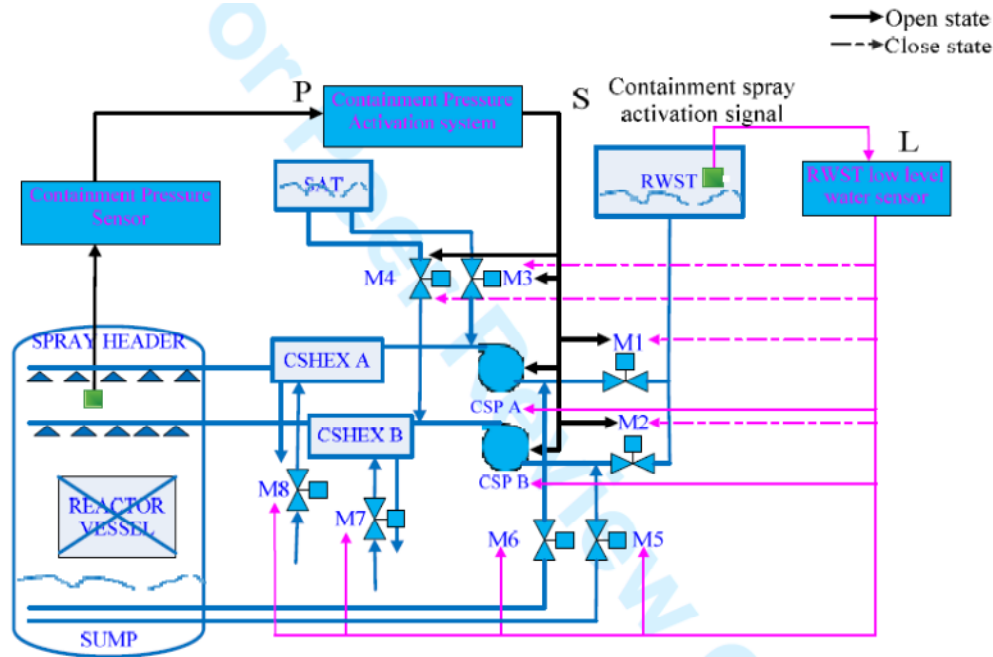

Fig. 5: Containment spray system in case of two lines running simultaneously

sprayed into the containment vessel (recirculation mode; phase 2) (JNESO, 2005).

In the case of LOCA, time span of phase one is 0-1800 sec and that for second phase is 1800-3600 sec for GO-FLOW analysis. The time point 1800 second for shifting from phase 1 to 2 is taken by an engineering judgment that water storage should be large enough to cover the needed time for continuous injection of water by both ECCS and containment spray for large break LOCA in cold leg.

GO-FLOW modeling of containment spray system:

In the real configuration of containment spray system, two parallel injection lines are assumed to run simultaneously as shown in Fig. 4 and these two lines are expressed in a GO-FLOW model in Fig. 5. In the GO-FLOW model of containment spray system, test line is neglected. CSHEXs secondary side is cooled by CCWS but it is also neglected. The redundancy system of two lines enhances the reliability and can wash the radioactive material in containment more quickly as compared to single line and also reduced the containment pressure to atmospheric pressure. In the two lines containment spray model for GO-FLOW analysis, the following assumptions are made: two CSP pumps and two heat exchangers and 8 motor-operated valves, each valve corresponding to each line. The abbreviations used in the GO-FLOW model of containment spray system are as follow, RWST stand for refueling water storage tank, SAT spray additive tank; CSHEX containment spray heat exchanger, CRS containment recirculation sump and M1 to M8 are motor-operated valves. RWST, SAT, CSHEX and CRS

are passive components, which have no need of any power source for actuation.

SCP is active one which needs source for actuation and it should open in both phases. But the motor-operated valves from M1 to M8 are active ones which have open and close state.

In the control system of containment spray system, P is containment pressure activation system, S is containment spray activation signal and L is low level water signal of RWST. During the LOCA, M1 to M4 and CSP A and B are open on the receipt of high containment pressure signal (injection phase) and M5 to M8 and CSP A and B are open on the receipt of low level water signal of RWST (re-circulation phase). In the control system, solid lines represent the open state and dotted lines represent the close state of the components.

GO-FLOW calculation for PWR containment spray system (redundancy case):

The PWR containment spray system is modeled in the GO-FLOW chart as shown in Fig. 6. In the GO-FLOW chart, there are two phases, for phase 1(injection phase), RWST, SAT, two CSP (A and B) and four motor –operated valves from M1 to M4 are needed. For phase 2, SUMP, CSHEX, A and B, two CSP (A and B) and four motor operated valves from M5 to M8 are required. In GO-FLOW chart analysis, 10 time points were declared by operator number 4. The operation of system is demanded 5 time points for phase 1 and 5 time points for phase 2. The time point 1 is an initial state and at time point 2 system operations is demanded in phase 1. There is equal time interval between consecutive time points. For the

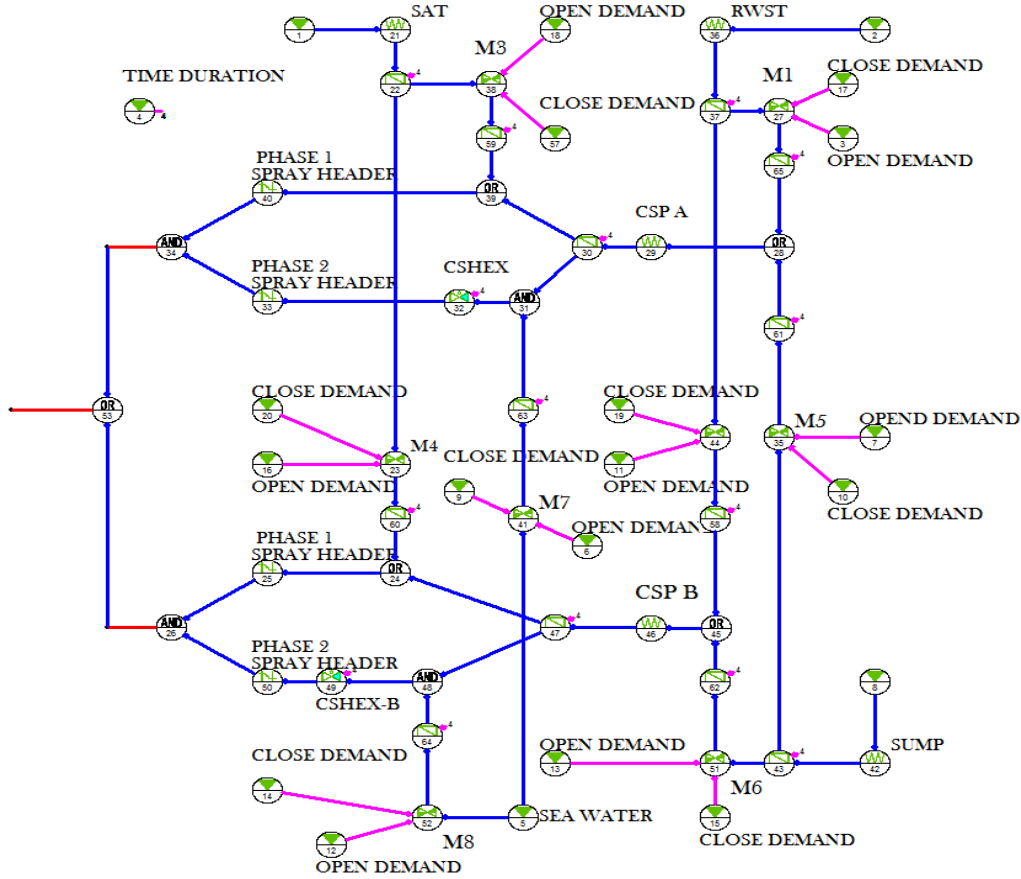

Fig. 6: GO-FLOW chart in case of two lines running simultaneously

Table 1: Operation and failure rate used in the present analysis

Components	Kind	Success probability or failure rate	Phase 1	Phase 2
RWST	Passive	$P_g = 0.999999, \lambda_o = 1 \times 10^{-5} / \text{sec}$	On	Off
SAT	Passive	$P_g = 0.99, \lambda_o = 1 \times 10^{-5} / \text{sec}$	On	Off
CRS	Passive	$P_g = 0.999999, \lambda_o = 1 \times 10^{-5} / \text{sec}$	Off	On
CSHEX	Passive	$\lambda_o = 1 \times 10^{-8} / \text{sec}$	Off	On
CSP	Active	$P_g = 0.99, \lambda_o = 1 \times 10^{-5} / \text{sec}$	On	On
M1, M2, M3, M4	Active (Open and close action)	$P_o = 0.96 / \text{demand}, P_c = 1.0 / \text{demand}, P_p = 0.96, \lambda_o = 1 \times 10^{-9} / \text{sec}, \lambda_c = 1 \times 10^{-8} / \text{sec}$	On	Off
M5, M6, M7, M8	Active (Open and close action)	$P_o = 0.96 / \text{demand}, P_c = 0.96 / \text{demand}, P_p = 0.0, \lambda_o = 1 \times 10^{-8} / \text{sec}, \lambda_c = 1 \times 10^{-8} / \text{sec}$	Off	On

successful operation of the system, it is assumed that the system will operate for 4200 sec. Time is taken for the behavior of typical PWR containment spray system during the large break LOCA. In the GO-FLOW chart, the operators, 26, 34 and 53 present the output signal. These output signals give the result of GO-FLOW analysis. The GO-FLOW analysis results can be consists of failure probability or successful probability of system. Table 1 (U.S. NRC, 1975; IAEA (International Atomic Energy Agency), 1989) show the operation of components and reliability data which is assigned in the GO-FLOW analysis:

- where,
- P_g = Probability for successful operation
- P_p = Probability for premature operation
- P_o = Probability for valve successfully open
- P_c = Probability for valve successfully close

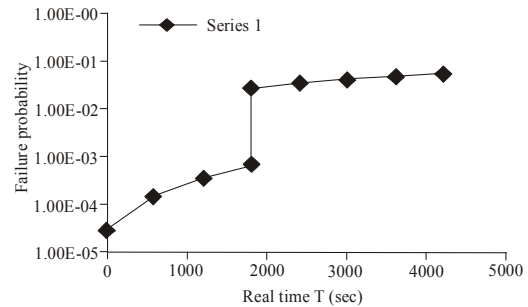

Fig. 7: Failure probability of containment spray system

- λ_o = Failure rate for open state
- λ_c = Failure rate for close state

In this study, author has considered the result of GO-FLOW analysis as the failure probability of PWR

containment spray system. The failure probability curve versus time is shown in Fig. 7. The failure probability is very small in phase 1 and rapidly increases with time in phase 2, because the availability or reliability of nuclear power plant has been affected adversely by the failures of the components with the passage of time and systems which are not safety significant but responsible for a reliable power production.

This dynamical reliability of phased mission system that is, containment spray system is not final evaluation therefore further study has been conducted by considering sensitivity analysis, uncertainty and common cause failure for more reliable results.

CASE 2: SENSITIVITY CALCULATION TO PRIORITIZE SEVERAL IMPORTANT PARAMETERS TO THE DYNAMIC RELIABILITY

The sensitivity analysis is a technique used to determine the appropriate values assign to the numerical item in the model and how these values of an independent variable will impact a particular dependent variable in a given set of assumptions. It is applied in reliability evaluation study how sensitive the reliability is with respect to changes in input parameters or model assumption of the system model. If the portion change in the model output (results), is large compared to the change in input, we say that the system is sensitive to the input element that was changed. A sensitivity studies identify the important epistemic uncertainties and quantification of the latter. In a risk-informed environment, the proper role of sensitivity studies is “to identify what is important to the results, not to replace uncertainty analyses (IAEA (International Atomic Energy Agency), 1992)”.

In this study, sensitivity analysis has been made by GO-FLOW methodology to prioritize the several important parameters to the dynamic reliability of the containment spray system.

In GO-FLOW analysis, there are ten time points and operators 53 represents the final signal that is failure probability as shown in Fig. 7. For sensitivity analysis, the results of failure probability have been considered at time point 5 and 10 for phase 1 and 2 respectively. The most significance terms in the failure probability results at time point 5 and 10 for phase 1 and 2 are given in first and second lists respectively

Failure probability result for phase 1 at time point 5, first list.

- IM = 86 90 0 0 0 0 0 0 0.00049346
- IM = 86 108 91 0 0 0 0 0.00002857
- IM = 104 90 87 0 0 0 0 0.00004430
- IM = 104 90 88 0 0 0 0 0.00001107

Failure probability result for phase 2 at time point 10, second list.

- IM = 81 0 0 0 0 0 0 0.004113118
- IM = 99 82 0 0 0 0 0 0.00160184
- IM = 99 92 0 0 0 0 0 0.00160346
- IM = 109 92 0 0 0 0 0 0.00160507
- IM = 109 82 0 0 0 0 0 0.00160346

According to first list, the largest contributions to failure probability results produced by signals 86, 90, 108, 91, 104 and 87. These signals are internally generated and can be identified by “Signal Intensities At All Time Points” and GO-FLOW chart structure, as has been explained in third list in order to find the relative original operators.

Third list

- 86 ---- >37
- 90 ---- >22
- 108---- >102---- >39(-->59)
- 91---- >85---- >24(-->60)
- 104---- >94---- >28(-->65)
- 87---- >76---- >45(-->58)

For example the operator 39 has the following terms (GO-FLOW chart and analysis result).

- 39 = 43, 93, 95, 96,
- 37, 94, 95, 97
- 22, 102

And operator 39 has input from operators 59 and 30.

- 59 = 22
- 30 = 43, 93, 95, 96
- 37, 94, 95, 97

By comparing the terms of 39, 59 and 30, the internally generated signal 102 is the contribution from operator 59. Similarly, with same procedure others, parameters can be identified. Thus, the important contribution to the failure probability results for phase 1 is produced by following original parameters 22, 37, 58, 59, 60 and 65. The main contributions operators from original parameters and their upstream operators in phase 1 are given in Table 2.

But the parameters 23, 27, 38 and 44 all type 39 operators and have the successful close probability $P_c = 1/\text{demand}$ at time point 6 (close demand) therefore, they are omitted for uncertainty analysis. Parameters with high sensitivity may be therefore, not necessary be associated with great uncertainty. So the parameters for sensitivity analysis are 21, 22 and 37.

Similarly, according to second list the largest contributions to failure probability results produced by 92, 82, 99, 109 and 81. These signals are internally generated and can be identified by “Signal Intensities At All Time Points” and GO-FLOW chart structure as shown in fourth list in order to find the relative original operators.

Table 2: Main contribution for phase 1

Important Parameters	Upstream operators	Largest failures operators	Main contribution operators
43	42	43 = 0.036	43
33	32, 63, 41, 30, 29	30 = 0.036, 41 = 0.04	30, 41
50	49, 64, 52, 47, 46,	47 = 0.036, 52 = 0.04	47, 52
61	35, 43, 42	35 = 0.04, 43 = 0.036	35, 43
62	51, 43, 42	51 = 0.04, 43 = 0.036	51, 43

Table 3: Main contribution for phase 2

Important parameters	Upstream operators	Largest failures operators	Main Contribution operators
37	36	37 = 0.018	37
22	21	21 = 0.01, 22 = 0.018	21, 22
59	38, 22, 21	38 = 0.04, 22 = 0.018	22, 38
60	23, 22, 21	23 = 0.04, 22 = 0.018	22, 23
65	27, 37, 36	27 = 0.04, 37 = 0.018	27, 37
58	44, 37, 36	44 = 0.04, 37 = 0.018	44, 37

Fourth list

- 81--->43
- 82---->77---->45(--->62)
- 92---->26(---->50)
- 99---->93---->28(--->61)
- 109--->34----->(--->33)

The internally generated signals have been identified by the comparison method as like phase 1. So the important contribution to the failure probability results is produced by following original parameters 33, 43, 50, 61 and 62. The contributions from original parameters and their upstream operators in phase 2 are given in Table 3. These all parameters have been considered for uncertainty analysis because they all have a great impact on the results of failure probability.

Hence; input with high sensitivity should be further investigated with uncertainty analysis. Parameters with low sensitivity, on the other hand, should not be dedicated resources for further analysis since their impacts on the results are not of a significant order.

From above description of sensitivity analysis, the important parameters in phase 1 and 2 which have a great impact on the results are 21, 22, 30, 35, 37, 41, 47, 51 and 52. For checking their impact on failure probability results, analysis has been made by GO-FLOW methodology by changing the failure values 10 times larger and 1/10 smaller than the original one. The impact of parameter 21, 22 and 37 on failure probability results for phase 1 is shown in Fig. 8.

Similarly, the impact of parameters 30, 35, 41, 43, 47, 51 and 52 on failure probability results in phase 2 is shown in Fig. 9 and 10. From the results of sensitivity analysis as shown in Fig. 5, 6 and 7, there are two lines for each parameter, the upper line drawn by the failure value ten times larger than original one and lower line drawn by the failure value 1/10 times smaller than original one. From the Fig. 5, we can figure out which of the parameters affects the system failure probability more than the other one. So the more accurate estimation can be obtained for the most important one. In the case of phase 1, the parameter 21, is most sensitive.

Similarly, from Fig. 9 and 10 the parameter 43 is most sensitive in phase 2 than the others. Thus, the

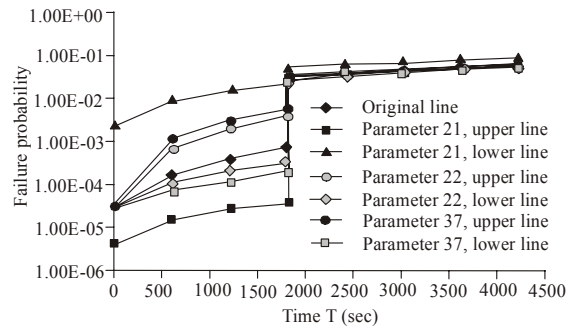

Fig. 8: Most sensitive parameter in phase 1

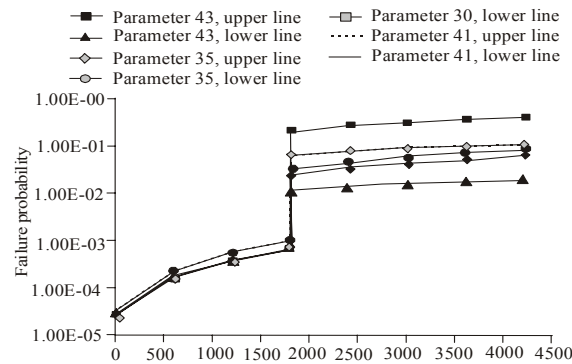

Fig. 9: Most sensitive parameter in phase 2

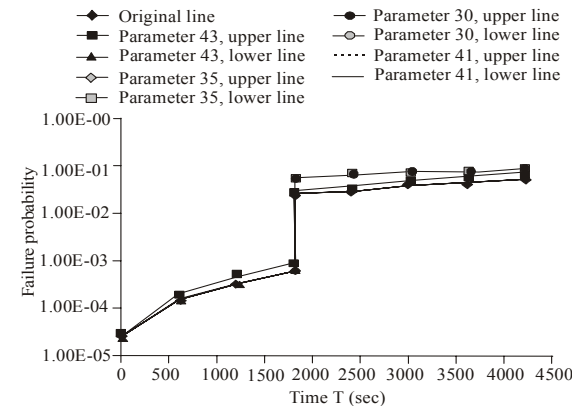

Fig. 10: Most sensitive parameter in phase 2

sensitivity analyses can therefore be used as a tool for identification of important parameters, which are more effective for reliability assessment. A sensitivity analysis can also be performed for measuring the effects of completeness uncertainty by including or excluding possible relevant elements like failure modes and then evaluate if they are significant for the results or not.

Uncertainty and common cause failure analysis for the selected important parameters for dynamical reliability: A task of uncertainty analysis is to determine the uncertainty features of the system outputs

as a function of uncertainties in the system model itself and the stochastic variables involved (Tung, 2011). The uncertainty analysis investigates the uncertainty of variables that are used in decision-making problems. It makes a technical contribution to decision-making through the quantification of uncertainties in the relevant variables. From the sensitivity analysis following important parameters, 21, 22, 30, 35, 37, 41, 47, 51 and 52 has been selected for uncertainty and common mode failure which have main contribution to system dynamic reliability results. However, the analysis of common cause failure and uncertainty analysis by GO-FLOW are not being presented in this study.

For uncertainty analysis, we can assume the appropriate distribution function such as “the normal, log-normal, homogeneous, log homogeneous, gamma, binomial, Weibull, beta and histogram distributions. For the procedure of treating the uncertainty analysis we can use the ELSAT version of GO-FLOW methodology which use the Monte Carlo method applied to the uncertainty analysis. Similarly, for common mode failure, it is important to make common cause groups of selected parameters which have same failure mode and have large contribution to system failure probability. In the present analysis, we can make three common cause groups such as:

Group 1: Spray additive tank (SAT, operator 22) and Refueling Water Storage Tank (RWST, operator 37).

The nature of failure or failure mode is- Failure during usage.

Group 2: Two containment spray pumps (CSP, Operators 30 and 47) and failure mode is- Failure during usage

Group 3: Three motor-operated valves (M6 to M8, Operators 41, 51 and 52) and failure mode is- Failure in open and close action

For common cause analysis, we can select the suitable parametric model out of four parametric models such as β -factor model (Fleming, 1975), Multiple Greek Letter model (Fleming and Kalinowski 1983), Binomial Failure Rate model (Atwood, 1983) and α -factor model (Mosleh and Siu, 1987). By making the common cause groups and suitable parametric model, we can follow the equations 4 and 5 and can make the common cause failure analysis by GO-FLOW method. It can be noticed from common cause failure analysis that which common groups has largest contribution to system failure probability and summing the failure probability of all common cause groups, the total system failure probability will be increased as compared to without common cause failure results.

Similarly, from the results of uncertainty analysis, you will obtain that uncertainty analysis is an important part of practical evaluation of the system

dynamic reliability where the results of system reliability are presented in the form of mean and informative quantiles (5, 50 and 95%). These results will make the reliability prediction more practical compared with the result without the uncertainty analysis. The results provide the valuable risk information to the operators for decision making to ensure the safe operation of nuclear power plant. Analysis of common cause failure and uncertainty analysis, authors will make in the next study.

CONCLUSION AND FUTURE WORK

In this study, authors have made the analysis of reliability for phased mission system by GO-FLOW methodology alternatively to Fault Tree Analysis (FTA) and Event Tree Analysis (ETA) because GO-FLOW methodology is success-oriented analysis technique. It has capability to evaluate the system unavailability and reliability of complex system and comparatively easy to conduct the analysis. In this study two cases have been conducted, in the first case, reliability analysis has been made for PWR containment spray system which is an example of phased mission system. In the reliability analysis of containment spray system, there two phases that are, injection phase and recirculation phase. The failure probability of safety system is very small in the first phase and uncontinuously increases in the second phase because the failure probability of system greatly effected due to increase of failure rate of safety components with the passage of time. In the second case, sensitivity analysis has been made in order to prioritize the important parameters which have largest contribution to system failure probability. The sensitivity analysis is made by changing values of the failure data of safety components 10 times larger and 1/10 times smaller than the original one. The important parameters are also selected for common cause failure analysis and uncertainty analysis. However, the analysis of common cause failure and uncertainty analysis has not been made in this study but authors have given the idea, how to make analysis of CCF by making the common cause groups from the selected parameters which have same failure mode and large contribution to the failure probability. And also by selecting the suitable parametric models such as β -factor model (Fleming, 1975), Multiple Greek Letter model (Fleming and Kalinowski 1983), Binomial Failure Rate model (Atwood, 1983) and α - factor model (Mosleh and Siu, 1987). Similarly, for uncertainty analysis, selection of appropriate distribution function is necessary from “the normal, log-normal, homogeneous, log homogeneous, gamma, binomial, Weibull, beta and histogram distributions”. Above study to evaluate the dynamical reliability of real containment spray system in the nuclear power plant does not give the sufficient information due to the lack of sufficient failure data as the input parameter. The further preparation will be needed to complete common mode failure analysis and

uncertainty analysis with the help of GO-FLOW, in order to conduct on practical evaluation of dynamical reliability of containment spray system in PWR.

ACKNOWLEDGMENT

The authors thank the financial support from National Natural Science Foundation (NFSC) of China (Grand No.60604036) and the 111 Project (Grand No. b08047) and China Government Scholarship.

REFERENCES

- Atwood, L., 1983. Common cause fault rates for pumps. Estimates Based on Licensee Events Reports at U.S. Commercial Nuclear Power Plants, January 1,1972, through September 30, 1980 NUREG/CR/2098, EG&G Idaho Falls, ID.
- Amenda, A. and G. Reina, 1984. Dylam-1: A Software Package for Event Sequence and Consequence Spectrum Methodology. EUR 9224 EN. Commission of European Communities, Luxembourg.
- Ching, J., S.K. Au and J.L. Beck, 2005. Reliability estimation for dynamical systems subject stochastic excitation using subset simulation with splitting. *Comput. Methods Appl. Mech. Eng.*, 2005(194): 1557-1579.
- Fleming, K.N. 1975. A reliability model for common mode failures in redundant safety systems general atomics report GA-13284. Proceeding of the 6th Annual Pittsburgh Conference on Modeling and Simulation, Instrument society of America, Pittsburgh, pp: 23-25.
- Fleming K.N. and A.M. Kalinowski 1983. An extension of the beta factor method to systems with high levels of redundancy. Technical report. Pickard, PLG-0289, Loweand Garrick, Inc., USA.
- Florent, B., S. Carol, B. Anne and B. Christophe, 2011. Dynamic reliability of digital-based transmitters. *Reliab. Eng. Syst. Safety*, 2011(96): 793-813.
- Hashim, M., T. Matsuoka, H. Yoshikawa and Y. Ming, 2012. Dynamical reliability analysis for ECCS of pressurized water reactor considering the large break LOCA by GO-FLOW methodology. *Int. J. Nucl. Safety Simul.*, 16(3): 81-90.
- IAEA (International Atomic Energy Agency) 1989. Survey of ranges of components reliability data for use in probabilistic safety assessment. TECDOC-508, Vienna.
- IAEA (International Atomic Energy Agency), 1992. Procedures for conducting common cause failure analysis in probabilistic safety assessment. IAEA-TECDOC-648, Vienna, ISSN: 1011-4289.
- JNESO (Japan Nuclear Energy Safety Organization), 2005. Outline of safety design (case of PWR). Long-term training course on Safety Regulation and safety Analysis Inspection 2005.
- La Band, R.A. and J.D. Andrew, 2004. Phased mission modeling using fault tree analysis. *P I Mech. Eng. E-J.Pro.*, 218(83).
- Liudong, X., 2007. Reliability evaluation of phased-mission systems with imperfect fault coverage and common-cause failures. *IEEE T. Reliab.*, 56(1).
- Liudong, X. and B.D. Joanne, 1999. Reliability analysis of static phased mission systems with imperfect coverage. M.S. Thesis, Department of Electrical Engineering, University of Virginia.
- Ma, Y. and K.S. Trivedi, 1999. An algorithm for reliability analysis of phased-mission systems. *Reliab. Eng. Syst. Safety*, 66(1999): 157-170.
- Matsuoka, T. and M. Kobayashi, 1997. The GO-FLOW reliability analysis methodology-analysis of common cause failures with uncertainty. *Nucl. Eng. Des.*, 175(1997): 205-214.
- Matsuoka, T. and M. Kobayashi, 1988. GO-FLOW: A new reliability analysis methodology. *Nucl. Sci. Eng.*, 98: 64-78.
- Matsuoka, T., 2010. GO-FLOW methodology-basic concept and integrated analysis framework for its applications. *Int. J. Nucl. Safety Simul.*, 3(9): 189-206.
- Mosleh, A. and N.O. Siu, 1987. A multi-parameter common cause failure model. Proceeding of the 9th International Conference on Structural Mechanics in Reactor Technology. Lausanne, August 17-21.
- Pinder, G.F., J.L. Ross, B.R. Mathon and M.M. Ozbek, 2006. Aleatory and epistemic uncertainty in subsurface flow. American Geophysical Union, Fall Meeting 2006, abstract #H31F-03. Retrieved from: adsabs.harvard.edu/abs/2006AGUFM.H31F..03P.
- Tung ,Y.K., 2011. Uncertainty and Reliability Analysis in Water Resources Engineering. *J. Contemp. Water Res. Educ.*, 103(1).
- U.S. NRC (U.S. Nuclear Regulatory Commission), 1975. Wash 1400 (NUREG -75/014) Failure Data. Appendix III to Reactor Safety Study.