

Research Article

Study on Calibration System for Electronic Transformers Based on High-Accuracy PCI Card

¹Mingzhu Zhang, ²Zhenxing Li and ²Kaicheng Li

¹School of Mathematics and Statistics, Xuchang University, Xuchang 461000, China

²State Key Laboratory of Advanced Electromagnetic Engineering and Technology, Huazhong University of Science and Technology, Wuhan 430074, Hubei Province, China

Abstract: With preliminary applying of Electronic Transformer (ET) based on IEC 61850 standards in power grid, the calibrations of tested transformers have attracted extensive research attention. This study proposes a novel Calibration System of ET (CSET) based on high-accuracy card. Data acquisition of ET and Standard Transformer (ST) is gotten by optic Ethernet and PCI-4462 data acquisition card, respectively. Meanwhile, the synchronized sampling between ET and ST is completed on the optic/electronic pulse signal of PCI synchronization card. The signals processing and human interface are realized by Labview software. The system proposed in the study is feasible for calibrating Electronic Voltage/Current Transformers (EVT/ECT) of different voltage classes. System tests show that the precision of the system can get to 0.2°.

Keywords: Calibration system, electronic transformers, PCI card, synchronism

INTRODUCTION

According to modern control theory, measurement of system state variable is a precondition to realize effective control of power system which is extremely complex and huge. With the development and construction of smart grid and digital substations, voltage/current measurement technology based on Electronic Transformers (ETs) plays a more and more important role in the system monitoring, protection and control. Compared with the traditional electromagnetic instrument transformers, ETs have higher performance-cost ratio, smaller size, better electromagnetic compatibility and more intelligent data exchange interfaces, etc. However, their measuring principles, system architecture and data output way, have undergone great changes (Ramboz, 1996), which bring new problems to the calibration of the transformers. Therefore it is necessary to design a new calibration system adapted to EITs.

Digital output of EIT is the main reason to change the conventional transformer calibration system (Branislav and Eddy, 2005). The digital output mode is based on the basic principles of EITs. The primary large current is transferred to secondary weak voltage by sensors based on Rogowski coils or Faraday coils. The analog signals of weak voltage are digitized at the high-voltage side and then are sent to merging units where they are synchronized. Finally, synchronized signals of multi-bays are packed in accordance with IEC61850 9-1/2 standards and then send to protection, metering and

control system (Zhi-Zhong, 2008). While the transfer of voltage for Electronic Voltage Transformers (EVTs), especially high-voltage transformers, is completed by capacitive dividers, the digital signals are sent to merging units and then to the second devices in the same way with ECTs (Pan and Tian, 2010).

From the basic principles of EITs, the calibrated objects of CSET include not only the metering sensor, but also the whole measuring circuit. Some papers described design of CSET on the whole (Djokic and Eddy, 2005). Zhi-Gang and Cheng-Mu (2006) designed the earliest CSET on virtual instrument platform based on acquisition card PCI 6013 card produced. But the accuracy of CSET is not enough for using the card with the accuracy of 0.03%. Pan and Xu (2009) utilize PCI card base on a high-accuracy analogue-to-digital (A/D) converter with the accuracy of 0.01% as DSS of CSET, which were less than 0.03% for magnitude error and 1 min for phase error. But the design lack of in-depth discussions for the key technologies, especially for metrological traceability of CSET itself.

In the CSET designed in this study, the traditional electromagnetic instrument transformers with an accuracy of one per ten thousand, the PCI card with high-precision of high sampling rate and digital signal processing algorithm with an accuracy of one per ten thousand together guarantees the high accuracy of CSET. The virtual instrument assures friendly interface of system operation platform and synchronous cards with phase error of only 10 ns can ensure synchronous sampling between calibrated ET and Standard

Transformer (ST) signal. The CSET takes EVT's with rated voltage varying from 10kV to 500kV and ECT's with rated current varying from 5A to 5000A into account. At the same time, this study tests the tested ET's using our own calibration system in the fields. Tests and results show that the designed CSET can meet the calibration of 2% precision electronic instrument transformers.

SYSTEM STRUCTURE

Digital output of ET is the main reason to change the conventional transformer calibration system (Hui-Xia and Wei, 2010). But the tested electronic transformer contains not only sensors at high-voltage side, but also the signal processing unit at high-voltage side and the merging unit at the low voltage side (Gurbiel *et al.*, 2009). In the system, the analog output of reference source is completed by standard electromagnetic current/voltage transformer which have high accuracy (0.01% level) and good stability under steady state which the problems of poor electromagnetic compatibility, easy magnetic saturation and big size are no longer problems. Meanwhile, the system should also be able to calibrate the special transformers with analog out which mainly apply in medium and low voltage power stations

Schematic diagrams of calibration system for ECT's with digital output and analog output are shown in Fig. 1 and 2 respectively.

The system has no distinct microcomputer-based instrument characteristics, the data sampling card and data synchronization card are settled in the personal computer and digital signals processing are realized by Labview software. The main functions of the system is to calculate the magnitude difference and phase difference between ET and ST, meanwhile it also calculate frequency and harmonic of ET. The system structure is composed with signal conversion units, data sampling units, data synchronization unit and Labview software technology.

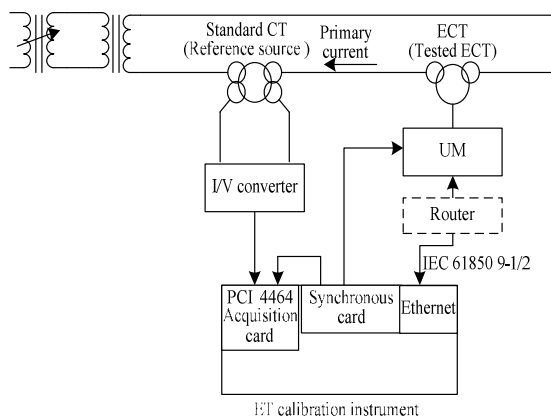

Fig. 1: Calibration system of digital output for ECT

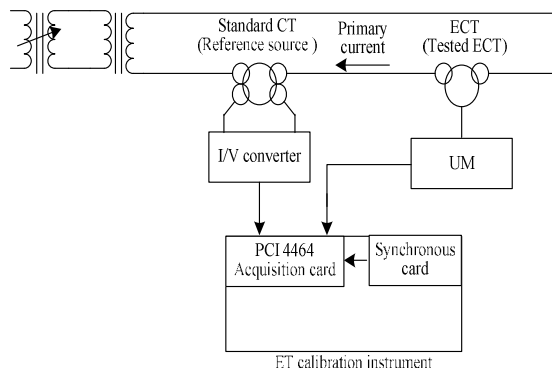

Fig. 2: Calibration system of analog output for ECT

- **Signal conversion unit:** The unit is to convert the secondary output current signal of standard current transformer to the voltage signal so that data sampling card can normally acquire reference information. The unit generally uses the shunt or precise resistance.
- **Data sampling unit:** The function is completed by high-precise data sampling card PCI-4462 produced by American NI Company. The study lists some basic parameters as the flowing:

- 24-bit resolution
- Sampling rates up to 204.8 kS/s
- Built-in anti-alias and TEDS function
- channel Synchronization trigger input (PFIO)

- **Data synchronization unit:** Data synchronization is the basic of the calibration system. It is not significant to comparison results if asynchronous sampling between ET and ST. The detail function is introduced in the next section.
- **Labview software:** Labview 8.6 has mighty system design platform based on graphical function. It not only can be used to fleetly small test automation system, but also be used to develop the large distributed data acquisition and control system, such as the calibration system.

DATA SYNCHRONIZATION

Data synchronization is the key of the calibration system and is realized by our own PCI synchronization card. The card is designed to output two ways of electric trigger pulse signals and two ways of optical synchronous pulse signals simultaneously, to adapt to merging units with different receiving modes of synchronous signals. Merging unit resets its sampling counter when receiving a synchronous second pulse, while data acquisition card PCI-4464 starts signal collecting when receiving a trigger pulse. After receiving the calibration order, the synchronous card

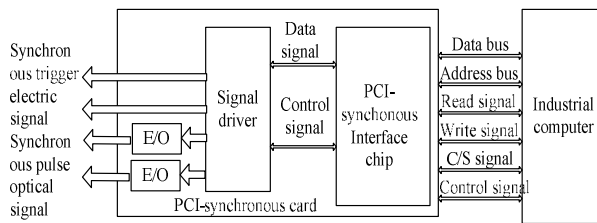

Fig. 3: Hardware diagram of data synchronization card

would alter trigger pulse to the low level at the rising edge of second pulse. The hardware diagram of the card is shown in Fig. 3.

To meet the reliable receipt of UM for the optic synchronized signal, synchronous signals must satisfy certain technical requirements. The rising edge of synchronous second pulse signals accounts for 50% maximum optical power. The rationality of synchronization signal is generally checked by UM and the incorrect synchronization state information based on IEC61850 standards is send to UM when time difference between the adjacent interval and the setting time (1s) is more than 10 μ s. Otherwise, the synchronization state is send. The calibration can manipulate only when UM receives synchronization signals.

SOFTWARE DESIGN

The software design includes human-computer interface design and digital signal processing.

Human-computer interface design: The calibration system is designed on Labview software. The human-computer interface is composed with parameter configuration interface, calibration results interface and calibration analysis interface.

The parameter configuration interface mainly finishes the parameter input of primary equipment, including the select of digital/analog signals input of ET, system rated primary/secondary values, communication standard, calibration channels and calibration times.

The calibration results interface completes some statistics of the calculated results, as Fig. 4 shows. The interface is the core of the whole system. Clicking one button manipulation button “Start” after completing parameters configuration, the system automatically complete signals sampling and processing and can get the calibration results including magnitude difference, phase difference, system frequency and waveform of each time and the statistics results, such as maximum, minimum, mean value and variance of the multi-time comparison results.

The calibration analysis interface realizes the realize time-domain analysis and spectrum analysis for

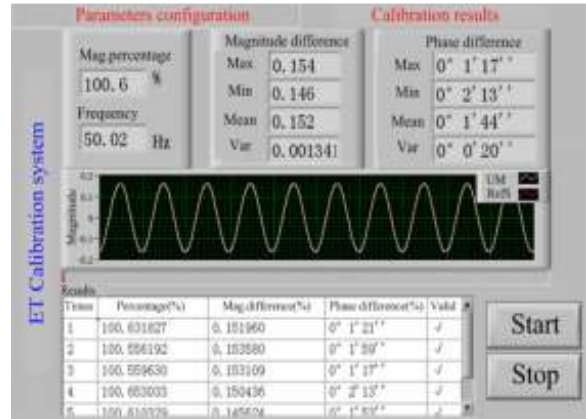

Fig. 4: Display interface of calibration analysis

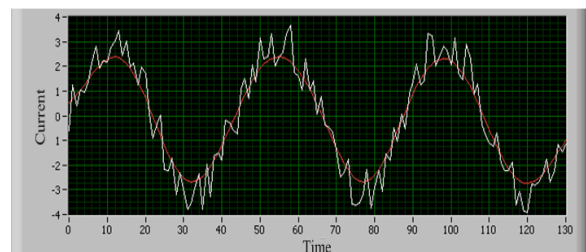

Fig. 5: Results of zero-phase filter test

ET and ST sampling signals. The system automatically analysis the spectrum amplitudes, DC, 2~20 times harmonic percentages and the total harmonic distortion rate of the unqualified signals.

Data signal processing:

- Digital filtering technology:** The input signals of ET and ST contain higher harmonic component and white noise besides fundamental wave component. Signal-to-noise ratio decreased obviously when Signal amplitude is lower. The signal quality is improved using the zero phase shift digital filter in Labview, which not only have very good filter effect for high frequency signal, but also have no phase shift and Amplitude attenuation. The simulation test results are shown in Fig. 5.
- Improved FFT algorithm based on Harming window interpolation:** The comparison of magnitude and phase are based on base wave signal. But there are still rich harmonic component in the signal which will serious effect the comparison results. At the same time the power frequency is not a constant value which brings certain effects on the sampling and the calculation of signal using FFT algorithm. The system utilizes improved FFT algorithm based on Harming window interpolation in Labview software to inhibit the influence of spectrum leakage and harmonic interfering signal.

Table 1: Results of amplitude and phase tests

Freq(Hz)	Calculated value		Error	
	Mag.	Ph.	Mag. (%)	Ph. Diff.
49	1.0001179	30°0.34"	0.00117911	0°0.34"
49.5	1.0000838	30°0.15"	0.00083828	0°0.15"
50	1.0000000	30°0.0"	0.00000000	0°0.0"
50.5	1.0000099	30°0.36"	0.0000991	0°0.36"
51	1.0000892	30°0.45"	0.00089241	0°0.45"

Table 2: Test results of phase a current for 10 times

Input	5% (In)		10% (In)		20% (In)	
	Mag.	Ph.	Mag.	Ph.	Mag.	Ph.
Max	-0.288	6.24"	-0.167	1.27"	-0.143	1.44"
Min	-0.306	4.41"	-0.182	1.02"	-0.155	0.42"
Mean	-0.297	5.20"	-0.176	1.11"	-0.151	1.21"
Variance	0.006	0.31"	0.005	0.10"	0.003	0.16"
Input	50% (In)		80% (In)		100% (In)	
	Mag.	Ph.	Mag.	Ph.	Mag.	Ph.
Max	-0.120	0.47"	-0.108	1.18"	-0.101	1.35"
Min	-0.128	0.32"	-0.118	1.01"	-0.112	1.15"
Mean	-0.124	0.42"	-0.112	1.14"	-0.105	1.26"
Variance	0.003	0.5"	0.003	0.7"	0.003	0.6"

Table 3: Test results of phase a voltage for 10 times

Input	70%(Vn)		80%(Vn)	
	Mag.	Ph.	Mag.	Ph.
Max	0.150	6'21"	0.129	3'69"
Min	0.130	4'66"	0.118	3'74"
Mean	0.141	5'21"	0.125	3'66"
Variance	0.004	0'25"	0.004	0'12"
Input	100% (Vn)		110% (Vn)	
	Mag.	Ph.	Mag.	Ph.
Max	0.075	0'45"	0.178	2'50"
Min	0.064	0'31"	0.097	1'10"
Mean	0.068	0'37"	0.153	1'57"
Variance	0.004	0'3"	0.003	0'17"

The simulation is test on Labview when input current magnitude is 1A and phase is 30°. The results are shown in Table 1.

SYSTEM TESTS

Type test: In order to check the correctness of the calibration system, tests in the laboratory as follows. ET and ST signal output are simulated through two standard signals outputted by 5720A multi-function calibration instrument produced by American FLUKE Company. And the system calculates the two channel signals to check the measurement precision. The measuring results show that calibration system can achieve 1/10000 of precision and can be calibration 0.2 level precision grades of electronic transformer.

Field test:

The calibration of ECT: According to the Fig. 1, ECT with 0.2 levels precision is checked in the fields. Input parameters are shown as the following:

Calibration channel: phase A
 Current rated ratio: 300A/1A
 Comparison times: 10

ET inherent delay: 188µs.

The results are shown in Table 2.

The results indicate that when current equals rated value, magnitude error is <2% and phase error is <2''; when current is no higher than 5% of rated ratio, magnitude error is <2% and phase error is less than 10''. The tested ET can reach the accuracy class of 0.2.

The calibration of EVT: According to the Fig. 1, EVT with 0.2 levels precision is checked in the fields. Input parameters are shown as the following:

Calibration channel: phase A
 Voltage rating ratio: 10kV/57.7 V
 Comparison times: 10
 ET inherent delay: 255µs.
 The results are shown in Table 3.

The results indicate that when voltage equals rated value, magnitude error is <2% and phase error is less than 2''; when voltage is no higher than 80% of rated ratio, magnitude error is <2% and phase error is <10''. The tested ET can reach the accuracy class of 0.2.

CONCLUSION

A design scheme of calibration system for electronic transformers is proposed. Its key technologies are discussed, including reference signal sampling, synchronous technique, signal processing technique and system platform. Field tests indicate that the designed calibration system is feasible and effective.

ACKNOWLEDGMENT

This study was financially supported by the Henan Province Department of Education Natural Science Foundation of China (12A110022), by the Henan Province Science and Technology Department Natural Science Foundation of China (122300410269).

REFERENCES

- Branislav, D. and S. Eddy, 2005. Calibration system for electronic instrument transformers with digital output. *IEEE Trans. Instr. Meas*, 54(2): 479-482.
- Djokic, B. and S. Eddy, 2005. Calibration system for electronic instrument transformers with digital output. *IEEE Trans. Instr. Meas*, 54(2): 479-482.
- Gurbiel, M., P. Komarnicki, Z.A. Styczynski, F.W. Gatzel and C. Dzienis, 2009. Merging unit accuracy testing. *IEEE Power and Energy Society General Meeting, Electr. Power Networks & Renewable Energy Sources*, Otto von Guericke Univ. Magdeburg, Magdeburg, Germany, pp: 1-6.
- Hui-Xia, Y. and G. Wei, 2010. Study and comparison on several different electronic transformer calibration methods. *Power Syst. Protect. Cont.*, 37: 99-101.
- Pan, F. and Y. Xu, 2009. Calibration system for electronic instrument transformers with analogue and digital outputs. *The 9th International Conference on Electronic, Measurement and Instruments*, 1: 650-654.
- Pan, H. and S. Tian, 2010. An adaptive synthesis calibration method for time interleaved sampling systems. *Metrol. Measur. Syst.*, 3: 405-414.
- Ramboz, J.D., 1996. Machinable rogowski coil, design and calibration. *IEEE Trans. Instr. Meas*, 45(2): 511-515.
- Zhi-Gang, M. and L. Cheng-Mu, 2006. Design of virtual calibrator for instrument transformer. *Transformer*, 43: 25-29.
- Zhi-Zhong, G., 2008. Review of electronic instrument transformers. *Power Syst. Protect. Cont.*, 36: 1-5.