

Research Article

Modification of Activated Carbon by Means of Microwave Heating and Its Effects on the Pore Texture and Surface Chemistry

Liqiang Zhang, Mi Mi, Bing Li, Yong Dong

National Engineering Laboratory for Coal-fired Pollutants Emission Reduction,
Shandong University, Jinan 250061, China

Abstract: Two kinds of typical Activated Carbons (coal based AC and coconut shell based AC) were modified in a flow of N₂ gas has been carried out using a microwave device operating at 2450 MHz and different input power, instead of a conventional furnace. The samples were analyzed by means of low temperature N₂ adsorption, elemental analysis and Boehm titration. The results show that microwave heating is an effective means of activated carbon modification. The temperature of activated carbon increases rapidly under microwave heating and then gradual increase to a quasi-stationary temperature. The pore texture of activated carbon changes slightly after microwave treatment and the two activated carbons still keep rich pore structure. The oxygen functional groups decompose and evolve with the form of CO and CO₂. This in turn gives rise to a significant decrease in oxygen content. These changes of oxygen contents increase as the microwave input power increases. During microwave treatment, a gradual decrease in the surface acidic functional groups is observed. More important, with the removal of the surface acidic groups, the number of the basic group increased gradually, the activated carbon with oxygen functional groups become basic properties material.

Keywords: Activated carbon, microwave treatment, pore texture, surface chemistry

INTRODUCTION

Activated carbon is widely used as adsorbents and also as catalysts as well as catalyst supports for gas-phase and liquid-phase application, due to its extensive surface area, well-developed microspore structure and the presence of functional groups of different types on the surface (Nilgun *et al.*, 2008; Nestor *et al.*, 2004). The physical and chemical characteristics of activated carbon can be controlled by the selection of precursors and activation methods and also achieved by post-treatment (Josefa *et al.*, 2010, Hui-Hsin and Ming-Yen, 2006). Thermal treatments in different gaseous environments are performed in order to adjust pore structure and surface chemistry (Lisovskii *et al.*, 1997; Daley *et al.*, 1997; Ohkubo *et al.*, 2000; Boudou *et al.*, 2003).

Microwave heating has been successfully applied for the preparation and regeneration of activated carbon (Foo and Hameed, 2011; Emine *et al.*, 2008). Microwaves supply energy to the carbon particles and this energy is converted into heat within the particles themselves by dipole rotation and ionic conduction. Microwave heating has the advantages of rapid temperature rise, uniform temperature distribution and saving of energy over conventional heating method (Carrott *et al.*, 2001). Hence, it is expected that

microwave heating will be a viable technology for the modification of activated carbon. So far, there are relatively few studies in this field. Menéndez *et al.* (1999) and Liu *et al.* (2010) have reported the surface modification of activated carbon and activated carbon fiber by means of microwave heating.

In this study, two kinds of activated carbons (coal-based and coconut shell-based) were treated in an atmosphere of N₂ using a microwave device under different input power instead of a conventional heating system. The effects of microwave heating on the pore texture and surface chemistry were characterized and analyzed.

EXPERIMENTAL

Microwave treatment: The commercial coal-based and coconut shell-based activated carbon manufactured by Shanghai Activated Carbon Co. Ltd. Were used as starting material (CAC and CSAC). In all experiments the particle size used was between 0.83 and 0.88 mm. Carbon AC was dried at a temperature of 105°C in an oven for 24 h to remove adsorbed water.

The microwave heating system shown in Fig. 1 consists of microwave generator and controller, multimode resonant cavity, temperature measuring

Corresponding Author: Liqiang Zhang, National Engineering Laboratory for Coal-fired Pollutants Emission Reduction, Shandong University, Jinan 250061, China

This work is licensed under a Creative Commons Attribution 4.0 International License (URL: <http://creativecommons.org/licenses/by/4.0/>).

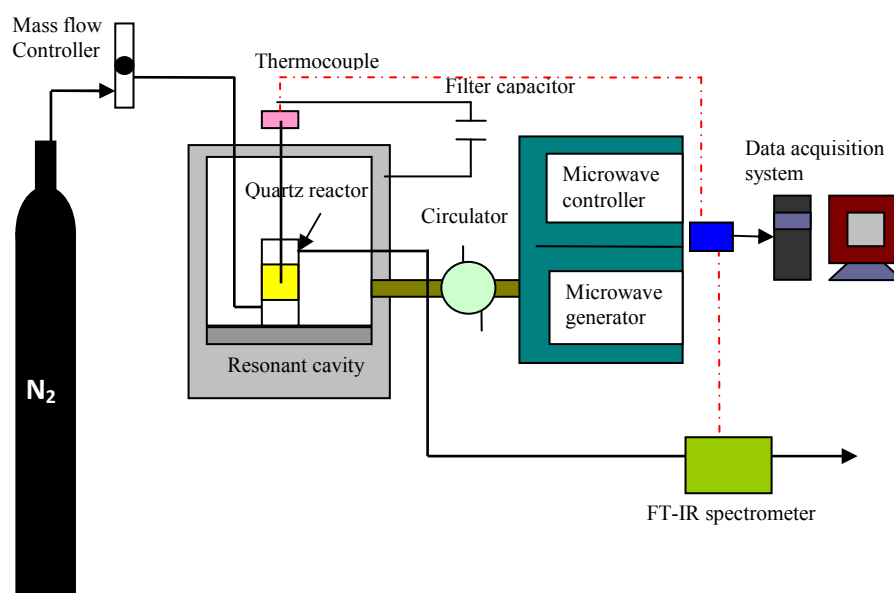

Fig. 1: Schematic diagram of microwave heating system

system, gas analysis and data acquisition system. The magnetron (model: LG-2M285) gives a continuous adjustable microwave power between 0 and 3 kW. The temperature of the carbon bed during microwave treatment was measured using a sheltered type-K thermocouple which was inserted into the center of the activated carbon bed. A filter capacitor is connected to the end of the leading wire of the thermocouple, as shown in Fig. 1, in order to eliminate high frequency interference from thermocouple induction.

Some AC was placed in a quartz reactor, at the bottom of which a perforated quartz plate was fixed to sustain the samples and the reactor was in turn placed inside a multimode resonant microwave cavity. Microwave treatment consisted in subjecting the samples to microwave heating at different microwave power for 15 min (samples were named AC-power). N_2 of 500 mL/min controlled by a mass flow controller (Seven stars CS200) was kept for 30 min before the microwave treatment to outgas air and was maintained during treatment and cool-down intervals. The microwave-treated activated carbons were stored in a sealed glass jar, which was purged with N_2 , in order to prevent the samples from being exposed to air. The input power of the microwave heating system was set at different power (100, 200, 300 and 400 W, respectively) and the microwave frequency used was 2450 MHz. The amounts of CO and CO_2 evolved during microwave treatment were monitored continuously using a Fourier-transform IR spectrometer (GASMET, DX-4000).

Physical and chemical characterization of activated carbon: The pore texture of the activated carbon was characterized by N_2 adsorption isotherms at 77 K using

a Quadra orb Station 1 instrument. The specific surface area was calculated from N_2 adsorption data using the BET equation. The total pore volume, microspore volume, the average pore width and pore size distributions were determined using DFT method.

Elemental analysis of carbon, hydrogen and nitrogen was carried out using a Vario EL 3 analyzer. The ash content was determined according to the standard test method for granular activated carbon. The oxygen content was determined by difference.

The analysis of surface functional groups was based on the Boehm titration method (Boehm, 1994). The basic groups were neutralized with 0.1 mol/L HCl solution. The acidic groups were neutralized with 0.1 mol/L NaOH solution.

RESULTS AND DISCUSSION

Microwave heating: The energy supplied by the microwave generator is deposited directly in activated carbon and the temperature reached will therefore depend on the fraction of the supplied energy which is actually adsorbed by activated carbon during microwave treatment. The ability of a carbon material to adsorb microwave energy depends on the nature of carbon as well as the microwave power applied to the sample (Haque, 1999). In the present experiments the amount of activated carbon, the moisture content, the particle size and the nature of activated carbon were all the same for all samples. Hence, the differences in the temperatures reached by each sample and its evolution during the treatment may be a consequence of the different microwave input power.

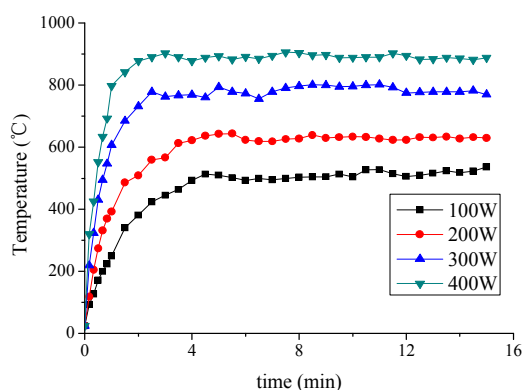

Fig. 2: Temperature-time courses of AC during microwave treatment at various input power

Figure 2 shows the evolution of the temperature of the activated carbon bed during microwave treatment at various input power. In all cases heating of the activated carbon is quite fast taking in the initial stage, however, the temperature is not constant during the 15 min of treatment. At the beginning, there is a rapid increase in temperature and then gradual increase to a quasi-stationary temperature. The larger the input microwave power, the more rapidly the temperature of activated carbon bed rises and the higher the temperature reaches in quasi-stationary stage. When the microwave power is as high as 400 W, the temperature rises up to 800°C in one min and reaches to the quasi-stationary stage, about 900°C, around two min after commencement of the treatment. When the power is 100 W, the temperature reaches about 500°C in 4 min.

Carboxyl, lactone, phenol, carbonyl and quinone groups, which present different thermal stability, have been identified on activated carbon surfaces. Surface oxygen functional groups on activated carbon decompose upon heating in an inert atmosphere by releasing CO₂ and CO at different temperature. Carboxylic acids give CO₂ at low temperatures and lactones give CO₂ at higher temperature. Carboxylic anhydrides give both CO₂ and CO. Phenols, ethers, carbonyls and quinones give CO at different temperatures (Figueiredo *et al.*, 1999; Biniak *et al.*, 1997).

The CO₂ and CO evolved during microwave treatment at different input power are shown in Table 1. Due to different temperature rising rate and final temperature under different microwave input power, the samples present different extents of decomposition of surface oxygen functional groups. The larger the microwave power, the more rapid the decomposition of surface oxygen groups, the more the amounts of CO₂ and CO evolved during microwave treatment. Small

Table 1: The evolved CO₂ and CO during microwave treatment at various input power

Sample	CO ₂ (μmol/g)	CO (μmol/g)
CAC-100	43.90	8.200
CAC-200	66.70	20.60
CAC-300	107.3	68.10
CAC-400	131.2	122.5
CSAC-100	439.4	99.80
CSAC-200	814.8	161.9
CSAC-300	975.6	640.9
CSAC-400	995.2	732.8

amounts of CO₂ are desorbed at the power of 100 W, indicating that there may be a few carboxylic groups which are decomposed at low temperature (Figueiredo *et al.*, 1999). The amounts of CO₂ evolved increase with microwave power increasing, indicating that there may be quantities of carboxylic anhydrides and/or lactones, which are relatively stable and decomposed at higher temperature. There is minimal amount of CO evolved during 100 W treatment, which may be originated from carboxylic anhydrides or phenols. The amounts of CO evolved increase with microwave power increasing, indicating that there may be quantities of phenols, carbonyls and quinones, which are decomposed at higher temperature.

Effect of microwave heating on the pore texture: The N₂ adsorption isotherms were analyzed by means of BET and DFT methods. The pore textural characteristics of the samples before and after microwave treatment are summarized in Table 2.

The as-received activated carbon, coal based activated carbon, has a well-developed porosity with a BET specific surface area of 1090 m²/g. Due to the loss of some mesopores during microwave treatments, microwave treatments slightly decrease the BET specific surface area, pore volume and microspore volume. These changes increase as the microwave input power increases. During microwave treatment, the activated carbons present a sharp temperature rise and this high temperature treatment causes the contraction of carbon skeleton and changes in pore structure. However, the contraction of carbon skeleton has the same effects on microspores and mesopores and pores of different width are shrinking, so, microwave treatment has little effect on the average pore width.

As to coconut shell based activated carbon, the pore volume is 0.3298 cm³/g, in which the microspore volume is 0.2755 cm³/g, shows that activated carbons are mainly micro porous. In general, the textural properties are quite similar in the all microwave treated case. The BET specific surface area and microspore specific surface area increased about 3%, the pore volume and microspore volume about 4% due to the microwave activation. So the increased specific surface

Table 2: Textural characteristics of the as-received and microwave-treated activated carbon

Sample	BET surface area (m ² /g)	Pore volume (cm ³ /g)	Micropore volume (cm ³ /g)	Mesopore volume / (cm ³ /g)	Pore width (nm)
CAC	1090	0.519	0.266	0.253	1.167
CAC-100	1067	0.510	0.252	0.258	1.167
CAC-200	1014	0.481	0.250	0.231	1.167
CAC-300	968	0.465	0.225	0.240	1.167
CAC-400	916	0.436	0.200	0.236	1.167
CSAC	618.1	0.3298	0.2755	0.0543	2.134
CSAC100	641.0	0.3400	0.2866	0.0534	2.122
CSAC200	642.5	0.3440	0.2842	0.0598	2.142
CSAC300	637.0	0.3377	0.2848	0.0529	2.120
CSAC400	646.3	0.3438	0.2871	0.0567	2.128

Table 3: Elemental analysis and acid-base groups of as-received and microwave-treated activated carbon

	Elemental analysis (wt %)				Acidic groups (mmol/g)	Basic groups (mmol/g)
	C	H	N	O		
CAC	79.43	0.60	0.41	8.52	0.11	1.12
CAC-100	80.33	0.62	0.43	7.42	0.06	1.15
CAC-200	81.69	0.55	0.39	5.83	0.01	1.19
CAC-300	84.33	0.54	0.37	3.42	0	1.20
CAC-400	86.19	0.59	0.36	1.51	0	1.23
CSAC	89.02	0.86	0.30	9.81	0.2375	0.5200
CSAC100	94.95	0.73	0.39	3.93	0.1469	0.5732
CSAC200	95.19	0.59	0.62	3.60	0.15	0.5829
CSAC300	95.82	0.69	0.39	3.10	0.10	0.6327
CSAC400	97.07	0.65	0.32	1.97	0.0625	0.6710

area and pore volume almost concentrated on micro pour. It is interesting to note that a microwave treatment of 100 W powers was sufficient to increase its textural properties. High power microwave treatments did not produce any further important changes in these parameter.

As commented above, microwave treatment has slight impacts on the textural properties and the results are in agreement with a similar lack of significant textural changes observed in other conventional thermally treated activated carbon (Figueiredo *et al.*, 1999; Lisovskii *et al.*, 1997; Daley *et al.*, 1997). The pore texture of activated carbon changes slightly after microwave treatment and the two activated carbons still keep rich pore structure.

Effect of microwave heating on the surface chemistry:

The results of elemental analysis given in Table 3 show that microwave treatment results in an increase in the carbon content for all microwave-treated activated carbons. This indicates an overall reduction in the total quantity of heteroatom's present in the samples. Microwave treatment produces minor changes in the contents of nitrogen and hydrogen. In particular, it should be noted that the oxygen content is always reduced. These changes in the contents of carbon and oxygen increase as the microwave input power increases. Although the reduction of oxygen present is particularly significant in AC-400, the oxygen content of CAC and CSAC is still 1.5 and 1.97%, respectively.

The amounts of the acid and basic surface groups on the original and treated activated carbon are shown in Table 3. The surface of CAC and CSAC are all

amphoteric with much more amounts of basic surface groups. Microwave treatment enhances the basic properties of the activated carbons at the expense of the acidic properties. Acidic surface oxygen functional groups are more weakly attached to the carbon surface than basic ones. During microwave treatment, acidic surface oxygen functional groups are released as CO₂ and CO. In particular, AC-300 and AC-400 fail to determine the acid surface groups which may be completely removed during the microwave treatment. However, the oxygen content of CAC-400 and CSAC-400 are still 1.5 and 1.97%, indicating that at least part of the oxygen is very strongly bound to the carbon surface in the form of surface functional groups, certain CO-yielding groups of a basic nature, which can resist temperature as high as 950°C and are not eliminated during microwave treatment.

The basic properties of activated carbons increase gradually with input powers increasing. The basic property of activated carbons is due to the presence of surface groups of a basic nature and to the contribution of the delocalized π-electrons of the basal planes which would be reinforced when surface oxygen functional groups are removed from the activated carbon surface (Leony *et al.*, 1992). Microwave heating treatment changes the nature and quantity of surface functional groups and has significant effects on the surface chemistry.

CONCLUSION

The results presented show that microwave heating in an inert environment is a very effective means of

modifying the properties of activated carbon to remove oxygenated functionalities from carbon surfaces and to obtain materials with basic properties. At the beginning, there is a rapid increase in temperature and then gradual increase to a quasi-stationary temperature. Microwave treatment has little effect on the pore texture of activated carbon. For the coal based AC, high temperature treatment causes the contraction of carbon skeleton and the loss of some mesopores. As to coconut shell based AC, which is mainly micro porous, BET specific surface area, the pore volume and microspore volume slightly increased under microwave treatment. Depending on the characteristics of the carbon sample, microwave-induced treatments can remove most of the oxygen-containing surface groups, especially those of an acidic nature. More important, with the removal of the surface acidic groups, the number of the basic group increased gradually, the activated carbon with oxygen functional groups became basic properties material.

ACKNOWLEDGMENT

The authors wish to thank the helpful comments and suggestions from my teachers and colleagues in Energy and environment lab of SDU at Jinan. And also thank Key Technologies R & D Program of Shan Dong province Beijing Up-tech to provide part hardware (2009GG2GC06013).

REFERENCES

- Biniak, S., G. Szymanski, J. Siedlewski, A. Swiatkowski, 1997. The characterization of activated carbons with oxygen and nitrogen surface groups. *Carbon*, 35(12): 1799-1810.
- Boehm, H.P., 1994. Some aspects of the surface chemistry of carbon blacks and other Carbons. *Carbon*, 32(5): 759-769.
- Boudou, J.P., Chehimi, M., E. Broniek, T. Siemieniowska and J. Bimer, 2003. Adsorption of H₂S or SO₂ on an activated carbon cloth modified by ammonia treatment. *Carbon*, 41(10): 1999-2007.
- Carrott, P.J.M., J.M.V. Nabais, M.M.L.R. Carrott and J.A. Menendez, 2001. Thermal treatments of activated carbon fibres using a microwave furnace. *Micropor. Mesopor. Mat.*, 47(2-3): 243-252.
- Daley, M.A., C.L. Mangun, J.A. DeBarr, S. Riha, A.A. Lizzio, G.L. Donnals and J. Economy, 1997. Adsorption of SO₂ onto oxidized and heat-treated Activated Carbon Fibers (ACFs). *Carbon*, 35(3): 411-417.
- Emine, Y., O. Meryem and A. Zeki, 2008. A novel method for production of activated carbon from waste tea by chemical activation with microwave energy. *Fuel*, 87(15-16): 3278-3285.
- Figueiredo, J.L., M.F.R. Pereira, M.M.A. Freitas, J.J.M. Qrfao, 1999. Modification of the surface chemistry of activated carbons. *Carbon*, 37(9): 1379-1389.
- Foo, K.Y. and B.H. Hameed, 2011. Microwave-assisted preparation of oil palm fiber activated carbon for methylene blue adsorption. *Chem. Eng. J.*, 166(2): 792-795.
- Haque, K.E., 1999. Microwave energy for mineral treatment processes a brief review. *Int. J. Min. Process.*, 57(1): 1-24.
- Hui-Hsin, T. and W. Ming-Yen, 2006. Effects of acid treatments of activated carbon on its physicochemical structure as a support for copper oxide in DeSO₂ reaction catalysts. *Chemosphere*, 62(5): 756-766.
- Josefa, J., M.A. Pedro and V. Gomez-Serrano, 2010. Oxidation of activated carbon by fry and wet methods: Surface chemistry and textural modifications. *Fuel, Process. Technol.*, 91(11):1768-1775.
- Leony, C.A.L., J.M. Solar, V. Calemma and L.R. Radovic, 1992. Evidence for the protonation of basal plane sites on carbon. *Carbon*, 30(5): 797-811.
- Lisovskii, A., G.E. Shter, R. Semiat and C. Aharoni, 1997. Adsorption of sulfur dioxide by active carbon treated by nitric acid: II effect of preheating on the adsorption properties. *Carbon*, 35(10-11): 1645-1648.
- Liu, Q.S., Z. Tong, N. Li, W. Peng and A. Gulizhaer, 2010. Modification of bamboo-based activated carbon using microwave radiation and its effects on the adsorption of methylene blue. *Appl. Surf. Sci.*, 256(10): 3309-3315.
- Menéndez, J.A., E.M. Menendez, M.J. Iglesias, A. Garcia and J.J. Pis, 1999. Modification of the surface chemistry of active carbons by means of microwave-induced treatments. *Carbon*, 37(7): 1115-1121.
- Nestor, T., M. Natalia, M. Fabiana, P. Javier, P. Carina and C. Tomas, 2004. Phenol adsorption onto powdered and granular activated carbon, prepared from Eucalyptus wood. *J. Colloid. Interf. Sci.*, 279(2): 357-363.
- Nilgun, K., O. Ilkun, Y. Reha, O. Ayse, 2008. Sulfur dioxide adsorption by activated carbons having different textural and chemical properties. *Fuel*, 87(15-16): 207-3215.
- Ohkubo, T., C.M. Yang, E. Raymundo-Pinero, Linares-Solano and K. Kaneko, 2000. High-temperature treatment effect of microporous carbon on ordered structure of confined SO₂. *Chem. Phy. Lett.*, 329(1-2): 71-75.