

## Research Article

# Engineering-Oriented Practical Training Methodology for Undergraduate and a Case Study

Jianyong Zuo and Zhongkai Chen

1Railway and Urban Rail Traffic Academy, Tongji University, Shanghai, 201804, P.R. China

**Abstract:** In this study, the education method which is different from traditional Chinese education methods for its accentuation of practical training is proposed. Compared with traditional engineering education methods, engineering-oriented practical training methodology is student-centered, contains various educational activities, requires interdisciplinary skills, values teamwork and have more objective evaluation methods. Based on the educational case of anti-skid control of railway train, a semi-physical simulation platform is introduced with details in design philosophy, system structure, operator interface and training process. The intention of creating the platform is to provide the students who use it with more hands-on experience since one of the key factors in transfer of learning is the diversion of practice. Based on the knowledge transfer theory, we encourage our students to do their work more independently and freely and the corresponding scores of their performance prove that the students who are better-rounded tend to perform well in the training courses we offered while those only with straight a scores may not outperform their classmates. Thus, the results indicate that this mode is effective in education and instructive to the reform of technological college education.

**Keywords:** Anti-slide control, case teaching, educational reform, practice training

## INTRODUCTION

These days, Chinese people increasingly see education as a critical component of democratic society. Traditionally speaking, Chinese education is characterized by teacher-centeredness and examination-orientedness, which hinder the development of the students' practical ability. The quality of Chinese education is further impaired by the major expansion in education, increasing the number of undergraduates and people who hold doctoral degrees fivefold in 10 years. As a result, the current labor market cannot fully absorb graduates produced by the cookie-cutter approach to teaching. According to the Ministry of Education, about 1.76 million graduates in China were jobless, accounting for 27.8% of the nation's college students, who graduated at the end of June, 2010. Tao Xiping, now vice-president of Chinese Education Association pointed out the traditional education patterns, particularly exam-oriented teaching and learning that focus on textbooks and exams, have greatly restrained the creativity and potential of the students. The commenter of Global Times noted that students coming out of Chinese Education system are of no use to society, because Chinese education reform is not fulfilling the needs of China's economic and social development (Zheng, 2009).

Many perspectives have been established regarding the theories of learning such as behaviorism, cognitivism, social cognitive theory and constructivism, but there is limited consensus on the crucial question of how much school knowledge transfers to tasks outside formal educational settings and how such transfer occurs (Perkins and Salomon, 1992). Such a disagreement explains why there are so many people like Larry Elision scorn the necessity of college education. Another indispensable ingredient in successful education is motivation which is mainly concerned with students' determination to finish tasks and their perspectives regarding possible failures. Thus, the central purposes of engineering-oriented practical training methodology are that students:

- Attain practical engineering experience
- Develop their confidence in problem-solving

Based on the application of the theories of knowledge transfer and motivation, engineering oriented practical training methodology dominates traditional engineering education methodologies theoretically.

One of the key advantages of the proposed methodology is practicality. Generally, the "hands-on" approach for educational experiments is essential for students' intellectual development. However, these traditional methods are costly and require complex

**Corresponding Author:** Jianyong Zuo, Railway and Urban Rail Traffic Academy, Tongji University, Shanghai, 201804, P.R. China

This work is licensed under a Creative Commons Attribution 4.0 International License (URL: <http://creativecommons.org/licenses/by/4.0/>).

logistics concerning space, staff, scheduling and safety (Feisel and Roas, 2005). As a simulation of natural experiments, virtual experiments are widely considered as a possible solution to these limitations. Nevertheless, some natural phenomena are hardly possibly to be simulated purely by computers. To exemplify, on account of the nonlinearity and fickleness of maximum braking force, the anti-skid control of railway trains is still puzzling many engineers. Those who stick to simulation results are tend to provide fallacious explanations. In light of this, the semi-physical simulation platform of anti-skid control is designed. Using the platform, students can easily write and test their anti-skid program, thus improving their ability of problem solving. The training scores of the students that participated in the recent training project show that above average students and average students can equally perform in this kind of training project. The questionnaire after the project reveals that the notion of the training project is well-accepted by students.

This study presented a new teaching methodology based on the theories of knowledge transform and motivation to overcome the inherent defects of traditional college education. The results obtained from the training program finished in October suggest that the engineering-oriented practical training methodology is equally effective for both above average students and average students. The feedback from the students involved in the project shows that the training methodology is quite welcome among senior university students.

#### **THE CONCEPTION OF THE ENGINEERING-ORIENTED PRACTICAL TRAINING METHODOLOGY**

In education, the phenomenon that learning in one context enhances or undermines a related performance in another context is defined as transfer of learning (Perkins and Salomon, 1992). Although most formal education aspires to transfer, it cannot be taken for granted. Very often the desired transfer from learning experiences does not occur. For instance, the renowned educational psychologist Thorndike (1923) disproved the proposition that studies of Latin sharpened the mind, preparing people for better performance in other areas (Thorndike, 1923). Regarding the impact of literacy on cognition, Scribner and Cole (1981) reported a study of an African tribe, finding that the impact of literacy depends on immersion in diverse activities surrounding literacy (Scribner and Cole, 1981). While most results concerning transfer appear to be negative, positive findings do have appeared occasionally. Salomon and Perkins (1989) showed that students can

improve their writing skills from a computer program designed to make students more strategic readers (Salomon and Perkins, 1989). According to Perkins, these findings together with others have led to suppositions of transfer conditions listed in Table 1.

Based on the suppositions above, the advantages of engineering-oriented practical training methodology over traditional engineering education methodologies may well be explained by their inherent characteristics indicated in Table 2. A majority of characteristics of engineering-oriented practical training methodology correlate conditions of transfer. Specifically, the needs of interdisciplinary skills and the diversity of educational activities stimulate students to utilize their learned skills more thoroughly and diversely; the style of student-centered learning and the scarcity of direct reference materials force students to be more aware of their activities and surroundings; the complex evaluation systems make students more concerned with their thinking process, thus helping them to extract valuable experience from what they have done. What's more, the closeness of the given tasks to real engineering problems can enlarge the part of near transfer in one's learning since near transfer usually have better prospects than far transfer.

As is mentioned before, another important ingredient in successful engineering education is motivation. Generally speaking, educational psychology research on motivation is generally concerned with the determination that students have to finish a task, their emotional investment, the personal plans that lead them to success and their thinking about the causes of their success or failure.

Elliot explained the impact of learners' goals on their success. Basically, there are 3 kinds of goals, namely, mastery goals, performance approach goals and performance avoidance goals. Specifically, mastery goals emphasize the increase of ability and knowledge; performance approach goals accentuate high grades and demonstration of abilities; performance avoidance goals drive people to avoid situations where their abilities are exposed. Research has found that mastery goals are related to positive outcomes such as persistence in time of difficulty, appetite for adventure and creativity. Performance avoidance goals usually yield negative outcomes including poor concentration, disorganization, less self-regulation, shallow information processing and test anxiety. Performance approach goals are associated with positive outcomes and some negative outcomes such as an unwillingness to seek help and shallow information processing.

Traditional engineering education methodologies generally lead to either performance avoidance goals or performance approach goals. Those straight a students usually focus too intensely on their academic

Table 1: Conditions of transfer

Conditions of transfer	Explanations
Thorough and diverse practice	Transfer may depend on extensive practice of the performance in question in a variety of context.
Explicit abstraction	Transfer sometimes depends on whether learners have abstracted critical attributes of a situation.
Active self-monitoring	Reflection on one's thinking processes appears to promote transfer of skills.
Arousing mindfulness	Mindfulness refers to a generalized state of alertness to the activities one is engaged in and to one's surroundings, in contrast with a passive reactive mode in which cognitions, behaviors, and other responses unfold automatically and mindlessly.
Using a metaphor or analogy	Transfer is facilitated when new material is studied in light of previously learned material that serves as an analogy or metaphor.

Table 2: Characteristics of practical training methodology and traditional methodologies

Engineering-oriented practical training methodology	Traditional engineering education methodologies
Student-centered learning: The focus is placed on the needs of the students.	Teacher-centered learning. The focus is placed on the needs of the teachers and administrators.
Educational activities include seminars, on-site experiments, searching for information, teamwork and so on.	Educational activities mainly include classroom teaching and homework.
Direct reference materials are hard to find because of the regular update of the assignments.	Reference materials are easy to find since the assignments remain unchanged for years.
The given tasks are closely related to real engineering problems.	The given tasks are usually imaginary and only used to explain the content covered in textbooks.
Teamwork is necessary because some of the tasks cannot be finished by individuals.	Teamwork is dispensable because the given tasks are independent to one another.
Evaluation is based on the performance in various aspects such as planning reports, final reports, test reports, peer assessment, outsiders' opinions, and most importantly, the final outcome of the given tasks.	Evaluation is basically divided into mid-terms, finals and class performance.

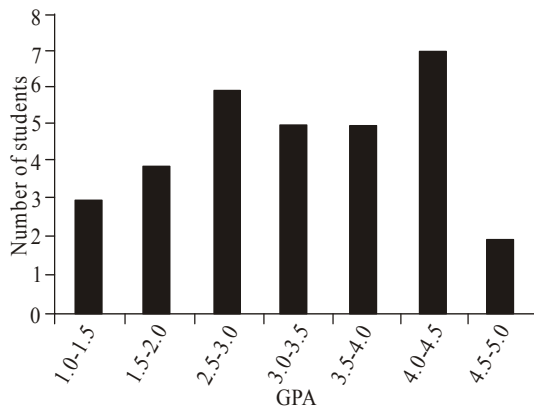

Fig. 1: The GPAs of graduates at institute of railway & urban rail transit in 2009

performance that they are no longer interested in widening their mental horizon through extracurricular activities. Those with poor scores, on the other hand, tend to give up on themselves and stop trying to make progress. As is observed by many Chinese educators, the GPA distribution of Chinese university graduates often do not accord with Gaussian distribution. Figure 1 illustrate the GPA distribution of our department and it seems that the average students (GPA from 3.0 to 4.0) are outnumbered by the combination of the below average (GPA from 0.0 to 3.0) and above average (GPA from 4.0 to 5.0) students. Ironically, the scores of their entrance examination are almost the same, which

implies that the abnormal distribution of GPA is not caused by different individual intelligence.

Unlike traditional engineering education methodologies, engineering-oriented practical training methodology encourages mastery goals. Because of the complex evaluation system, the students' sense of satisfaction is no longer purely influenced by external performance such as grades. Also, because of the scarcity of direct reference materials, they are forced to get rid of the exam-oriented mentality and thus spend more time on creating. In this way, they become more appreciative of teamwork and the process of overcoming difficulties, which is one of the central purposes of engineering-oriented practical training methodology.

### THE SEMI-PHYSICAL SIMULATION PLATFORM OF ANTI-SKID CONTROL

Anti-skid control systems are indispensable subsystems of electric multiple units and urban rail trains; they are used to prevent wheel set skid during braking cycles. By decreasing the air pressure in brake cylinders or the energy consumption of dynamic brake systems, anti-skid control systems can help rail train wheel sets regain their adhesion state. In general, the deceleration performance of rail trains is determined by 2 factors: the maximum value and the utilization ratio of potential braking force. The maximum value of

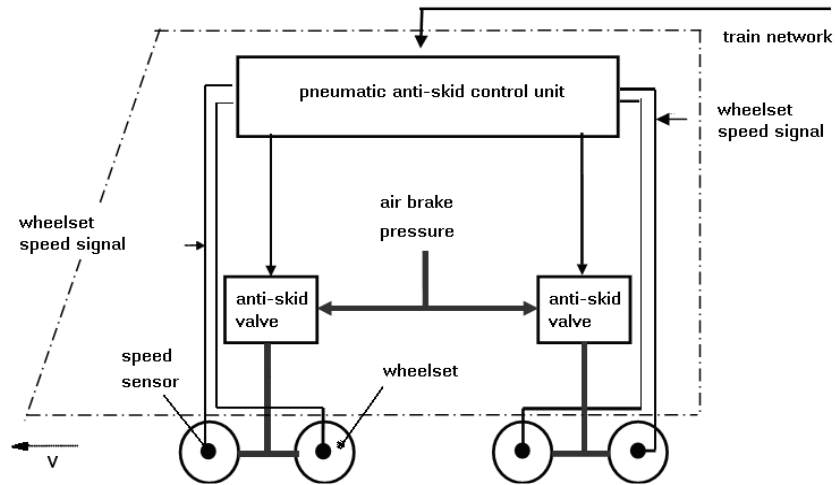

Fig. 2: The construction of a typical pneumatic anti-skid system

potential braking force is highly unpredictable due to the complex system characteristics and the environmental influences including air humidity, contact area cleanliness, the shapes of wheel sets and rails and so forth. Since the calculation of maximum braking force is infeasible, safety margin is required to prevent wheel sets from sliding. Nevertheless, larger safety margin spells poorer deceleration performance, which is negative for the development of high-speed trains and urban rail trains. Therefore, anti-skid control systems are crucial for improving the deceleration performance of rail trains since they can lessen the necessity of large safe margin. A typical anti-skid control system is composed of a pneumatic anti-skid control unit and a dynamic anti-skid control unit. The former is controlled by an air brake controller while the latter is controlled by a draft controller. The discussion in this study concentrates on pneumatic ones.

At present, the pneumatic anti-skid systems for high-speed trains and those for urban trains are quite similar. As is illustrated in Fig. 2, a typical pneumatic anti-skid system can be divided into speed detection units, anti-skid valves and pneumatic anti-skid control units. Specifically, the speed signals generated by speed sensors are collected by the pneumatic anti-skid control units, which then control the anti-skid valves according to the processing results of these signals; the anti-skid valves adjust air brake pressure, increasing or decreasing braking force as required so as to help wheel sets regain their adhesion state.

In short, the functions of pneumatic anti-skid control systems include the detection of wheel set speed, the actuation of anti-skid valves, the monitoring of failure conditions and the realization of safety circuits. For different pneumatic anti-skid control

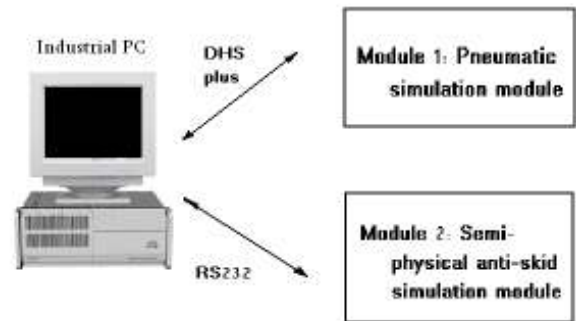

Fig. 3: The construction of the semi-physical simulation platform

systems, their operation principles are similar and the distinctions among them are different pneumatic characteristics and anti-skid control strategies.

**Overall structure of the platform:** As indicated in Fig. 3, the semi-physical simulation platform of anti-skid control is constructed by 2 modules: a pneumatic simulation module and a semi-physical anti-skid control simulation module. The former is used to simulate the pneumatic characteristics of rail train brake systems, whilst the latter is used to simulate and display the anti-skid control process. Figure 4 shows the appearance of the semi-physical simulation platform. At present, the practical training functions of Module 2 have been fully developed while the pneumatic simulation functions of Module 1 are still under optimization.

**Pneumatic simulation module:** To begin with, the pneumatic simulation module is built on DSH plus Platform and can be called by its upper computer.



Fig. 4: The appearance of the semi-physical simulation platform

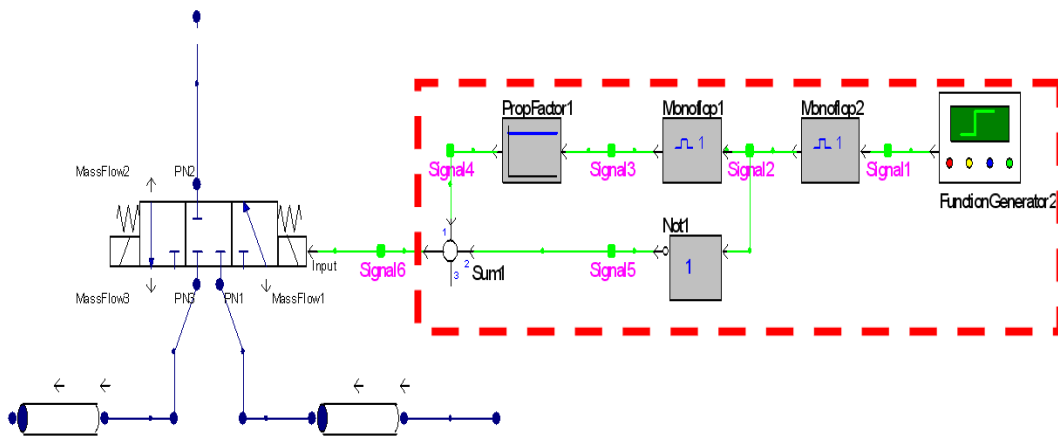

Fig. 5: The kernel program of module 1

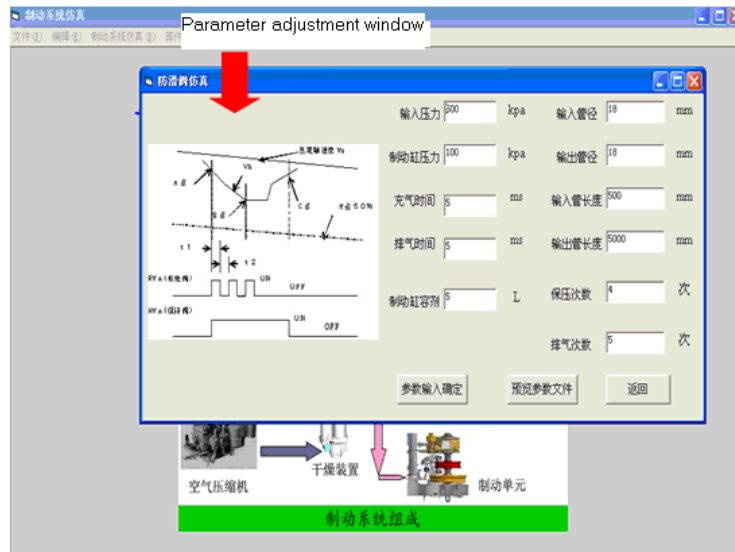

Fig. 6: The interface of the pneumatic simulation module

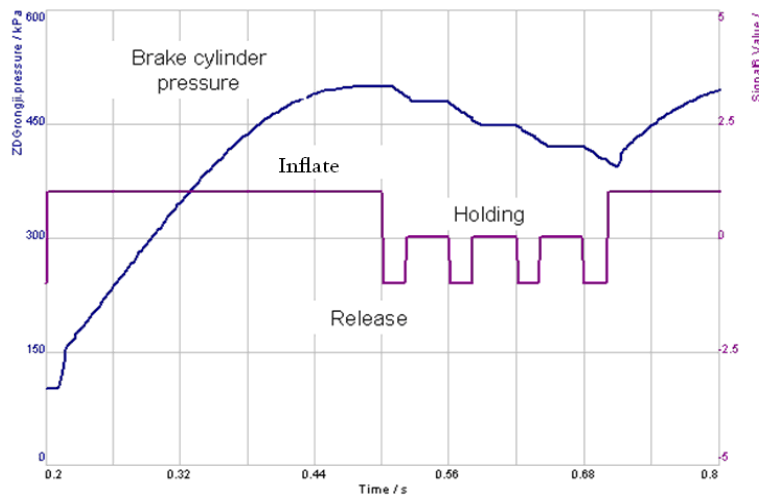

Fig. 7: A typical pneumatic test result

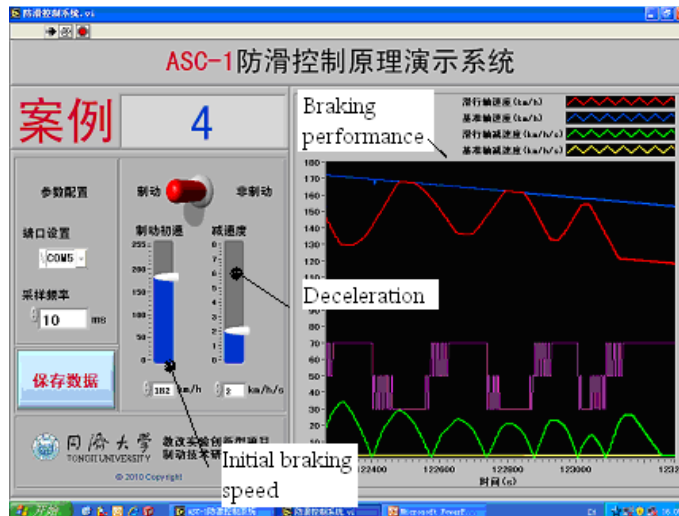

Fig. 8: The interface of the semi-physical anti-skid control simulation module

DSH plus is a simulation program especially developed for the dynamic nonlinear calculation of complex hydraulic and pneumatic systems and components. The kernel program of Module 1 is indicated in Fig. 5. The subprogram within the dashed frame can be reprogrammed by users so that different anti-skid strategies can be tested.

As mentioned above, the deceleration performance of rail train braking system is determined by system characteristics and environmental influences, which are both unpredictable. Thus, it is essential for anti-skid strategy designers to create strategies capable of handling different possible situations. By adjusting parameters in the parameter adjustment window shown in Fig. 6, users can quickly change the simulated characteristics of brake systems. In this way, the

pneumatic performance of different anti-skid strategies can be tested easily. (A typical pneumatic test result is shown in Fig. 7).

**Semi-physical anti-skid control simulation module:**

As is illustrated in Fig. 4, the communication between PC and the semi-physical anti-skid control simulation module is through a RS232 port. The PC is mainly responsible for realizing man-machine interaction functions including the adjustment of system parameters, the display of data and the edit of anti-skid control program. Specifically, the system parameters include initial braking speed, deceleration and sampling frequency (The interface of Module 2 is shown in Fig. 8).

Table 3: The functions of the sub modules of module 2

Submodule	Functions
Communication module	Realizes the data communication between Module 2 and the PC
Power module	Supplies power for embedded controllers
Case library	Provides various anti-skid control cases
Data acquisition module	Simulates the speeds of the reference wheel and the skidding wheel
Drive module	Actuates the anti-skid valve, the reference wheel motor and the skidding wheel motor

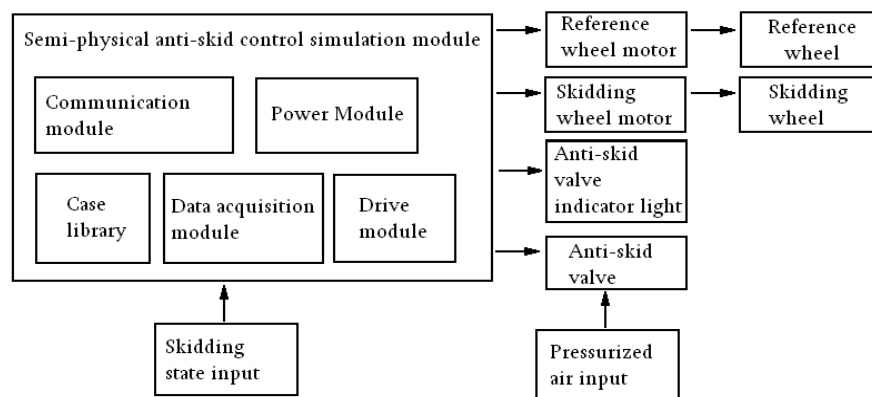

Fig. 9: The hardware structure of module 2

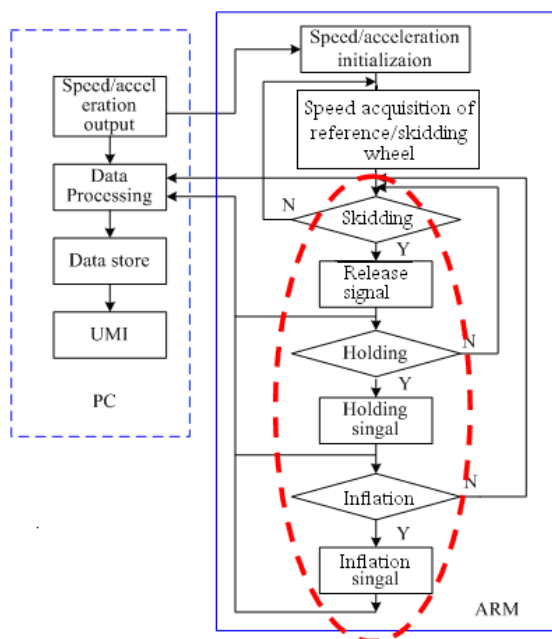

Fig. 10: The flowchart of the overall program of module 2

Basically, the design of Module 2 is oriented towards the convenient editing and testing of various anti-skid control programs. As can be seen in Fig. 9, Module 2 can be further divided into the following sub modules: a communication module, a power module, a case library, a data acquisition module and a drive module, of which the functions are listed in Table 3.

The semi-physical anti-skid control simulation module is built on ARM platform and its program flowchart is illustrated in Fig. 10. The program within the dashed frame is used for anti-skid control judgment, which is the main content of practical training. Essentially, the anti-skid function is realized by controlling the air pressure within brake cylinders. And the air pressure is managed by opening and closing the anti-skid valves according to different anti-skid strategies. By changing the reprogrammable part of the C program within the dashed frame, the platform users can test various anti-skid strategies efficiently.

As can be seen from Fig. 11, the platform offers an interface where users can easily post C program to ARM-based anti-skid controllers. For programming the ARM a Keil compiler (uVision) is used, but users do not see the compiler's interface. In the system there is only one way to upload source code to ARM controllers. When the uploaded code is correct, the code is loaded into ARM. Otherwise, the alarm indicator would notice users to rewrite their program.

### TEACHING CASE USING THE PLATFORM

As mentioned above, the engineering-oriented practical training methodology is oriented towards the cultivation of competent engineering graduates, which is quite attractive to senior students. The first practical training experiment started at Institute of Railway and Urban Rail Transit on September 28, 2010 and ended on October 20. There were 2 teachers involved in the training program. Besides, 25 seniors were recruited

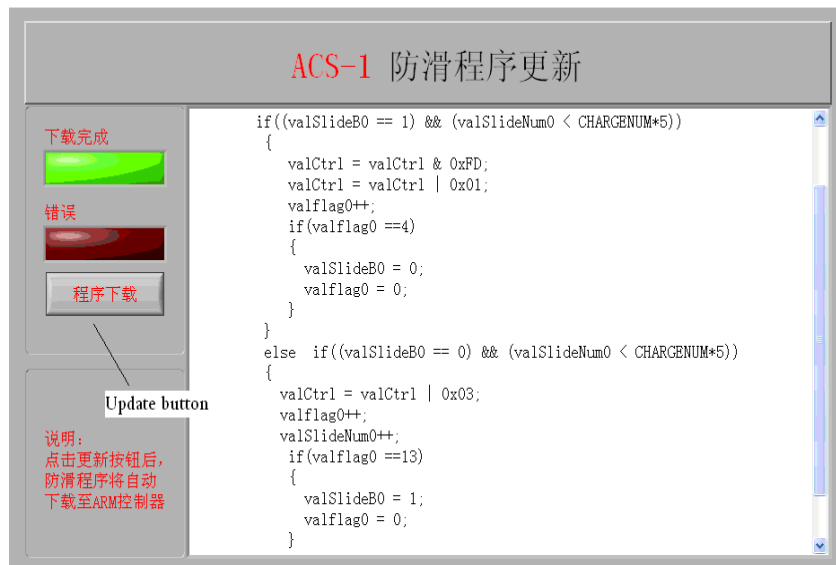

Fig. 11: The interface of c program uploading

from our department and there were also 5 postgraduate students from our department volunteering to be training assistants. Generally speaking, the teaching case was designed to attain following goals:

- To help the students understand the construction of anti-skid control systems and the functions of the parts of the systems
- To help the students understand the whole process of anti-skid control by using multimedia technologies
- To improve the students' skills of programming and data analyzing.
- To strengthen the students' confidence of solving problems
- To educate the students' team spirit

**The process of the practical training:** As can be seen in Fig. 12, the whole training process was divided into 3 phases, namely, background orientation, practical training and conclusion and evaluation.

The first phase was for preparation. During this phase the students were introduced to anti-skid control theory and the platform by teachers and training assistants. Each student was asked to hand in a planning report concerning the generalization of anti-skid knowledge and the research about worldwide information of anti-skid control. Then the students were divided into 5 groups according to their personal interests and skills.

The second phase was for practical training. During this phase, the 5 groups were asked to design their own anti-skid strategies according to received mission cards. The process of writing anti-skid program

and testing is iterative and each group had to design and test different anti-skid strategies until the mission requirements printed on their mission card were satisfied. For every different anti-skid strategy, they needed to write a short test report regarding the expectation and result of the strategy. Besides, each group member could evaluate the performance of their partners according to the evaluation standards by sending secret emails to the teachers every week. What's more, each group was observed by the training assistants regularly and the personal performance such as innovation, leadership and team spirit were kept in record. The training assistants were also required to give their own opinions about each group secretly.

The third phase was for conclusion and evaluation. During this phase, each group needed to hold a meeting discussing their perspectives about the whole training process and each student was required to submit a final report concerning the results of different anti-skid strategies and the self-evaluation. The teachers then scored the performance of the students according to their planning reports, test reports; final reports and the opinions of teachers and training assistants.

## THE RESULTS OF THE PRACTICAL TRAINING

Since the development of the engineering-oriented practical training methodology is still at the beginning, it is impossible to attain sufficient data for the analysis of the long-term effects of the methodology at present. However, some information regarding the practical training can still be revealed from the scores of the students indicated in Fig. 13. According to the bar graph, the training performance between students



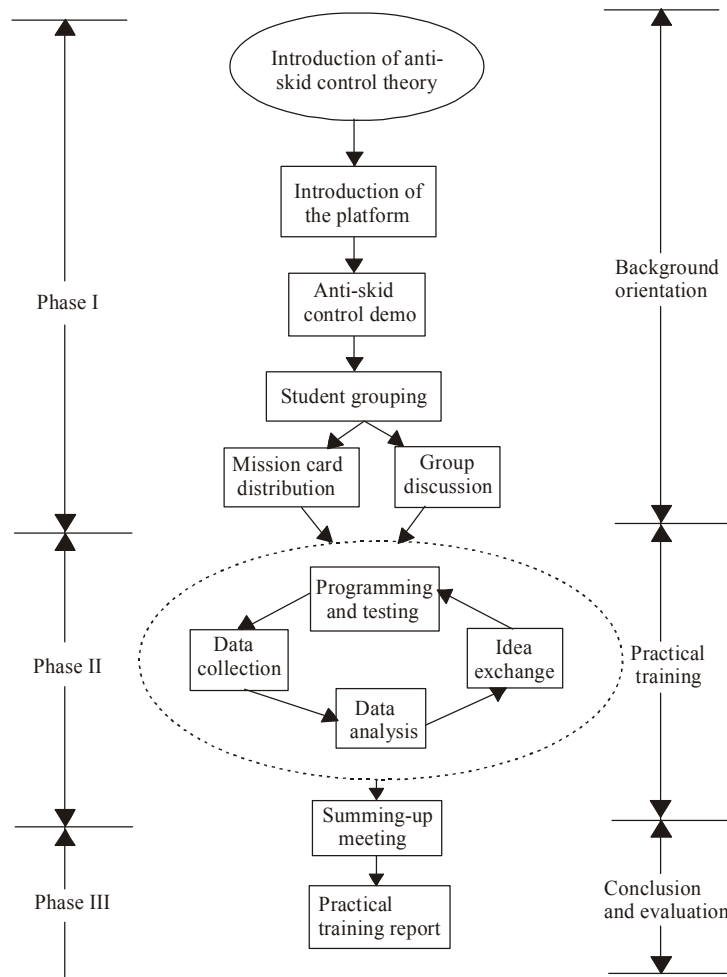

Fig. 12: the process of the practical training

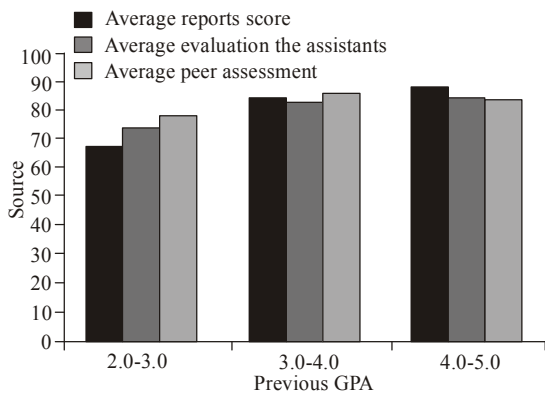

Fig. 13: The average training scores of the students grouped by previous GPA

whose previous GPA were from 3.0 to 4.0 and those from 4.0 to 5.0 is quite similar, which implies that the

tradition evaluation system does not necessarily reveal the students' ability and that average students can do as good as above average students in the setting of the teaching methodology.

After the practical training, each student was given a questionnaire table concerning their opinions regarding the teaching methodology. In Fig. 14, we get that most of the students, as many as 84%, believed that the training program did have deepened their understanding of the structure and of anti-skid control systems. What's more, when it comes to programming skills, 84% of the students involved held that they were more adept at programming after the project. Concerning teamwork skills, there were also 18 students believing that their interpersonal skills have improved owing to this particular project. Although these data alone cannot prove that the teaching case was a success, we do hope that, with the deepening of our investigation, more interesting findings about the teaching methodology will be revealed.

Question 1: The training project and the semi-physical simulation platform have led to a better understanding of the structure of anti skid control system.  
 Question 2: The multimedia technologies used in the project are help for the understanding of anti skid control process.  
 Question 3: The project has improved your programming skills.  
 Question 4: your confidence of problem solving has increased due to this project.  
 Question 5: your teamwork skills have improved due to this project.

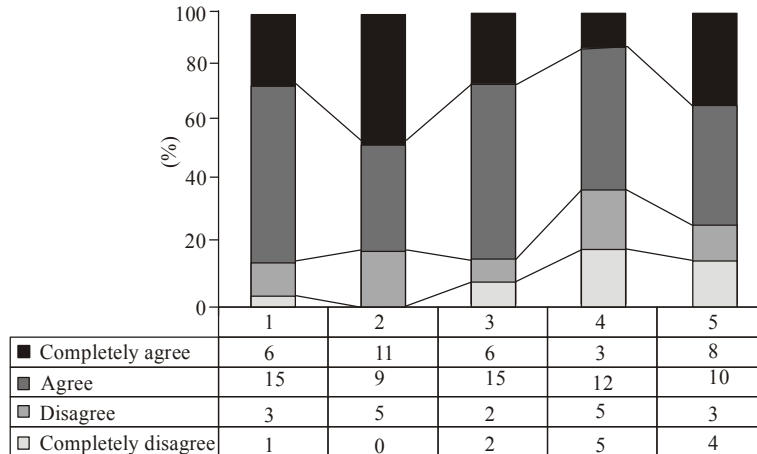

Fig. 14: Students survey results on their perceived improvement in skills

**CONCLUSION AND RECOMMENDATIONS**

This study presented a new teaching methodology based on the theories of knowledge transform and motivation to overcome the inherent defects of traditional college education. The results obtained from the training program finished in October suggest that the engineering-oriented practical training methodology is equally effective for both above average students and average students. The feedback from the students involved in the project shows that the training methodology is quite welcome among senior university students.

Nevertheless, the long-term effects of the teaching methodology are still unknown due to the lack of time and statistically sufficient feedback. Therefore, follow-up investigation will focus on the career development of the twenty students. In addition, we are planning to refine the original design of the semi-physical simulation platform and recruit more students into the training project so that more accurate information regarding the teaching methodology will be available.

**ACKNOWLEDGMENT**

This study was supported by National Natural Science Foundation of China (Grant No. 61004077) and

Program for Education Reform and Innovation Research in Tongji University (Grant No. 2860104011).

**REFERENCES**

Feisel, L.D. and A.J. Roas, 2005. The role of laboratory in undergraduate engineering education. *J. Eng. Educ.*, 94: 123-130.  
 Perkins, D.N. and G. Salomon, 1992. Transfer of Learning: In *International Encyclopedia of Education*. 2nd Edn., Pergamon Press, Oxford, UK, pp: 100-105.  
 Salomon, G. and Perkins, D.N. 1989. Are cognitive skills context bound? *Educ. Res.*, 18: 16-25.  
 Scribner, S. and M. Cole, 1981. *The Psychology of Literacy*. Harvard University Press, Cambridge, Massachusetts.  
 Thorndike, E.L., 1923. The influence of first year Latin upon the ability to read English. *School Sociol.*, 17: 165-168.  
 Zheng, Y.N., 2009. China’s Education Reform Bubble Bursts. *Global Times*, Retrieved from: [http:// www.globalcitizen.net/ database /? page = 1491 and category = articles and id =15494](http://www.globalcitizen.net/database/?page=1491&category=articles&id=15494).