

Research Article

An Interleaved Soft Switching Boost Converter with Bidirectional Full Bridge Inverter for Photo Voltaic Power Generation

¹P. Veena, ²V. Indragandhi and ¹R. Jeyabharath

¹KSR Institute for Engineering and Technology, India

²Parisutham Institute of Technology and Science, India

Abstract: In this study, an interleaved soft switching Boost Converter is used to track the maximum power point of PV array and full bridge inverter is used to stabilize the dc bus voltage. In this method, an interleaved technique is adopted to reduce the current rating of each device. Switching losses are reduced by adapting a zero voltage transition which increases the efficiency of the system. The experimental results are verified using Power SIM simulation software during open loop and closed loop operation. Compared to hard switching technique the results imply that 1% of overall efficiency is improved in this system.

Keywords: Interleaved, MPPT, photo voltaic, PWM-VSI, soft switching, ZVT

INTRODUCTION

The power generation using photovoltaic is now a fast growing technology because of its unique characteristics like long life, presence of semiconductor devices will not produce the mechanical vibrations, maintenance cost is less and it is gifted to solve the problem of global warming.

The power generation using photovoltaic is done in two steps; in the first step the less voltage produced by the PV module is improved by using the interleaved soft switching boost converter. In the second step the dc bus voltage stabilization is done by using full bridge bidirectional inverter. Also the converter ensures the maximum power point tracking of PV module in order to meet out the temperature variations problem. To achieve the maximum efficiency in the load, the losses in the converter stage and inverter stage must be low while transmitting the power from photo voltaic cell (Rong-Jong *et al.*, 2007; Lee *et al.*, 2009). In this study, high efficiency interleaved soft switching boost converter with a bidirectional full bridge inverter is used to maximize the efficiency. We studied the boost converter using hard switching technique for power transmission. The drawback in this converter is that the number of components used in the commutation circuit is high. Due to this components the switching losses in the circuit is increased, consequently it decreases the efficiency of the power conditioning system (Han *et al.*, 2010; Lee *et al.*, 2011). We studied the operation of soft switching boost converter with single switch, for given duty ratio the voltage the across the switching device is high in this converter (Dos *et al.*, 2001; Da Silva *et al.*, 2006). We studied about soft switching techniques

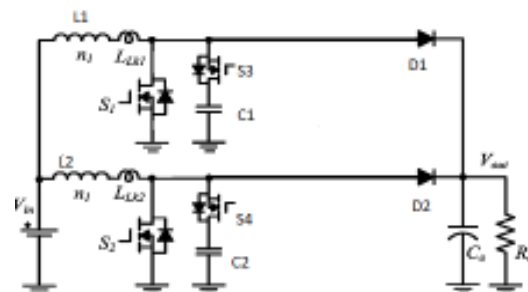

Fig. 1: Interleaved soft switching boost converter

which reduces the voltage and current stresses in the circuit consequently it reduces the capacitive turn on losses in the soft switching boost converter. In this study, the switch is turned off at zero voltage and turned on at zero current to ensure the maximum efficiency (Chok-You, 2002; De Oliveira Stein *et al.*, 2004; Li *et al.*, 2011).

This study presents the efficient operation of photo voltaic power generation scheme using Bidirectional inverter fed from interleaved soft switching boost converter. This system improves the overall efficiency 1% by reducing switching losses.

PROPOSED METHODOLOGY

Interleaved soft switching boost converter: We studied about interleaved boost converter with less number of power switches. Interleaved soft switching coupled inductor boost converter with active clamp is shown in Fig. 1. The active clamp circuit in the converter circuit is used for reducing the leakage of

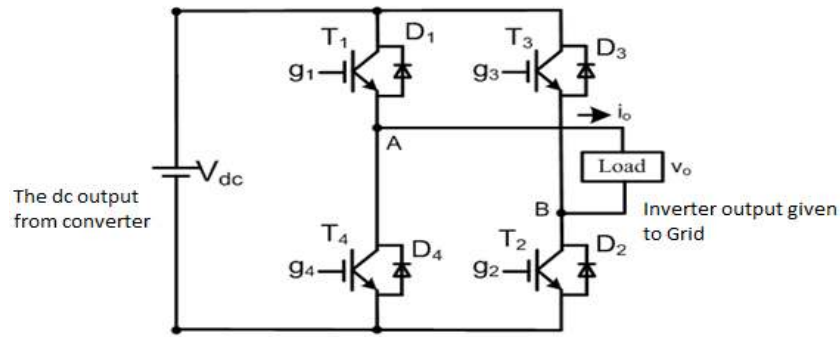

Fig. 2: Single phase bidirectional full bridge PWM inverter control strategy for an inverter

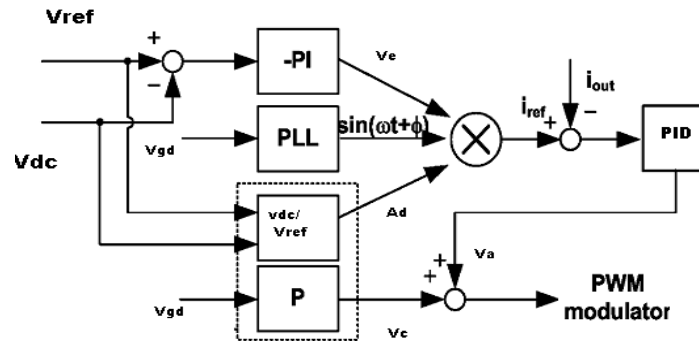

Fig. 3: Control strategy for an inverter

energy in the coupled inductors thereby it helps to improve the efficiency by Tseng *et al.* (2009). The current through inductor is reduced to half because the total current allowed to flows through the two inductors are same and the inductors size is also reduced. The ripple current present in the input is less due to the presence of these coupled inductors. The L_1 and L_2 are the main inductors used for magnetization. S_1 and S_2 are the switches used for main operation. S_3 and S_4 are the switches used for active clamping. D_1 and D_2 are the diodes connected to the output. The commutation of the switches S_1 to S_4 is done by zero voltage transition. C_1 and C_2 are the capacitors used for clamping.

The advantages of an interleaved soft switching boost converter are given below:

- The turns ratio n_2/n_1 is directly proportional to V_{out}/V_{in} . In order to get more voltage gain the value of turns ratio is to be adjusted. The voltage ratio is calculated by:

$$G = \frac{V_{out}}{V_{in}} \quad (1)$$

$$\text{Voltage gain} = \frac{\left(\frac{n_2}{n_1}\right)+1}{1-\left(\frac{T_{on}}{T}\right)} \quad (2)$$

- By increasing the voltage ratio, the voltage stress across the switching devices can be reduced. It will also helps to increase the overall efficiency of the

system by reducing the switching losses in each switch. The stress in terms of voltage can be calculated by using the equation:

$$\text{Voltage stress} = \frac{\text{Output voltage}}{\text{Turns Ratio}+1} \quad (3)$$

- The problem of reverse recovery is reduced by using the leakage inductance present the circuit and soft switching is done by all the switching devices present in the circuit which reduces the switching losses (Bin and Zhengyu, 2010; Choi *et al.*, 2008).

Bidirectional full bridge inverter: Figure 2 shows the single phase bidirectional full bridge PWM inverter. The output from the interleaved soft switching boost converter is given to this inverter through dc link. The main function of this inverter is to stable the output obtained from the PV cell. Naturally, the output of the PV cell is not stable and it is affected by the temperature variations in the atmosphere. Another function of the inverter is, the output of the Boost converter is in the form of dc which is not directly fed to the grid. For converting that dc voltage into sinusoidal output the pulse width modulation based voltage source inverter is used in this study. Here the distortion due to harmonics is considerably reduced in the output.

The control strategy of the switches in the bidirectional inverter is shown in Fig. 3. The output of

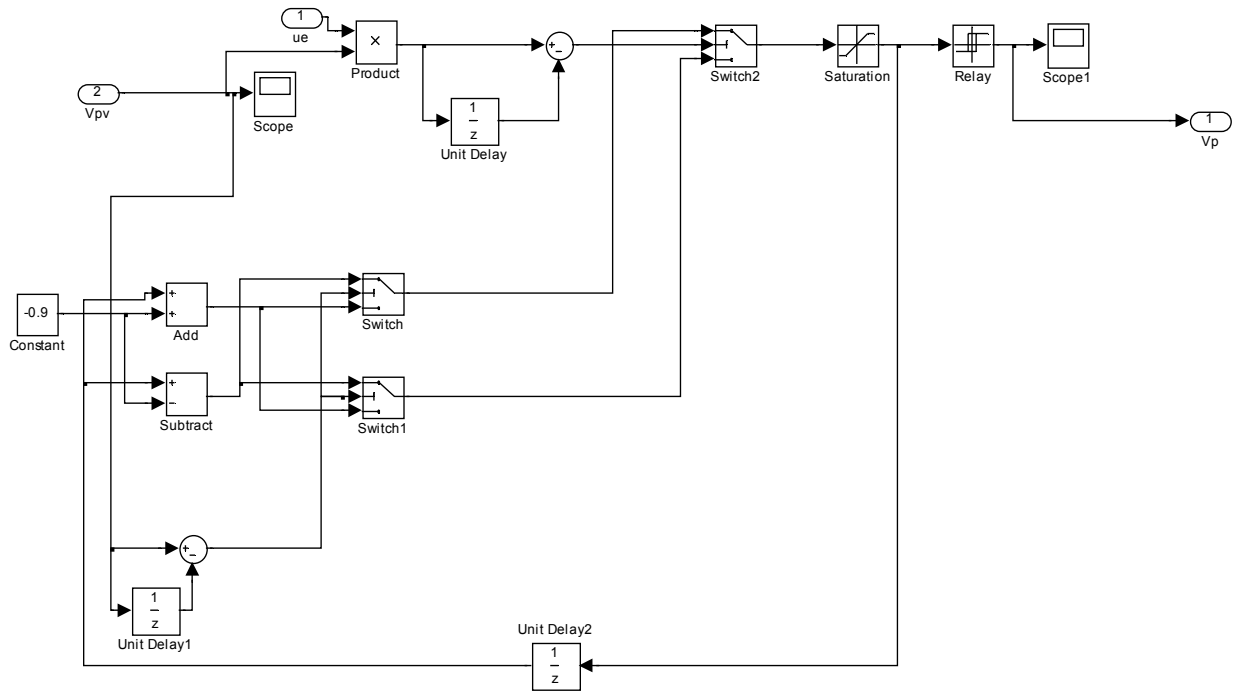

Fig. 4: Subsystem for MPPT

the negative PI controller is increasing when the dc voltage is more than the reference voltage. Now the power available in the Photo voltaic cell is transferred to the grid. Output of the PI controller is decreasing when the dc voltage is less than the reference voltage and the power is now transferred to the PV cell from the Grid. Likewise the stabilization of voltage is done by this control strategy. In order to maintain the error value at zero the dc voltage is adjusted and equated to reference value. Depends on the error signal, the inverter works as a converter or works as an inverter (Zitao, 2009; Kazmierkowski and Malesani, 1998). Ad is compensation factor which is ratio between the dc bus voltage and the reference voltage:

$$Ad = \frac{V_{dc}}{V_{ref}} \quad (4)$$

The digitalized PLL is used here which is used to match the grid voltage with frequency in real time.

Subsystem for MPPT: Photovoltaic cells are having a problem of producing maximum power due to the irradiance, temperature variations in the atmosphere presented at Carbone (2009). A lot of MPPT practices are carried out to make best use of the generated PV cell power by Qiang (2012).

In this study, a simple MPPT solution is used and it ensures the entire power generated by PV array is transferred to the grid without any loss. The load currents are directly proportion to the PV array power. So that all the MPPT techniques are concentrating to

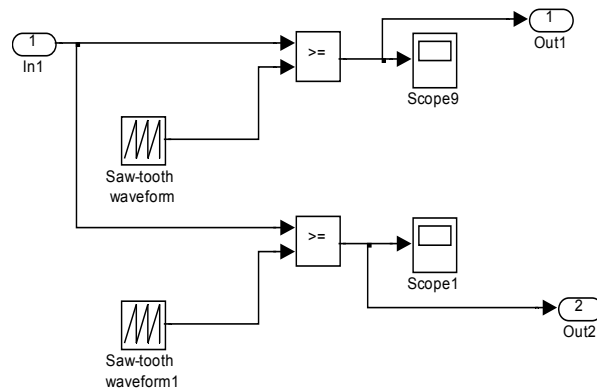

Fig. 5: Subsystem for PWM

control the error V_e . Here in this study the perturb and observe algorithm are used to enhance the output of the PV array. The Fig. 4 shows the subsystem for MPPT. Here in this technique instead of taking care on voltage and current, the power transfer capability is maximized.

Subsystem for PWM: The Fig. 5 shows the subsystem for pulse width modulation technique. The full bridge inverter with bidirectional flow is used to stabilize the voltage. The saw tooth wave is generated for reference.

SIMULATION RESULTS

The power SIM simulation software is used to analyze the open loop and closed loop operation of “An interleaved soft switching boost converter for

Open loop simulation diagram and results

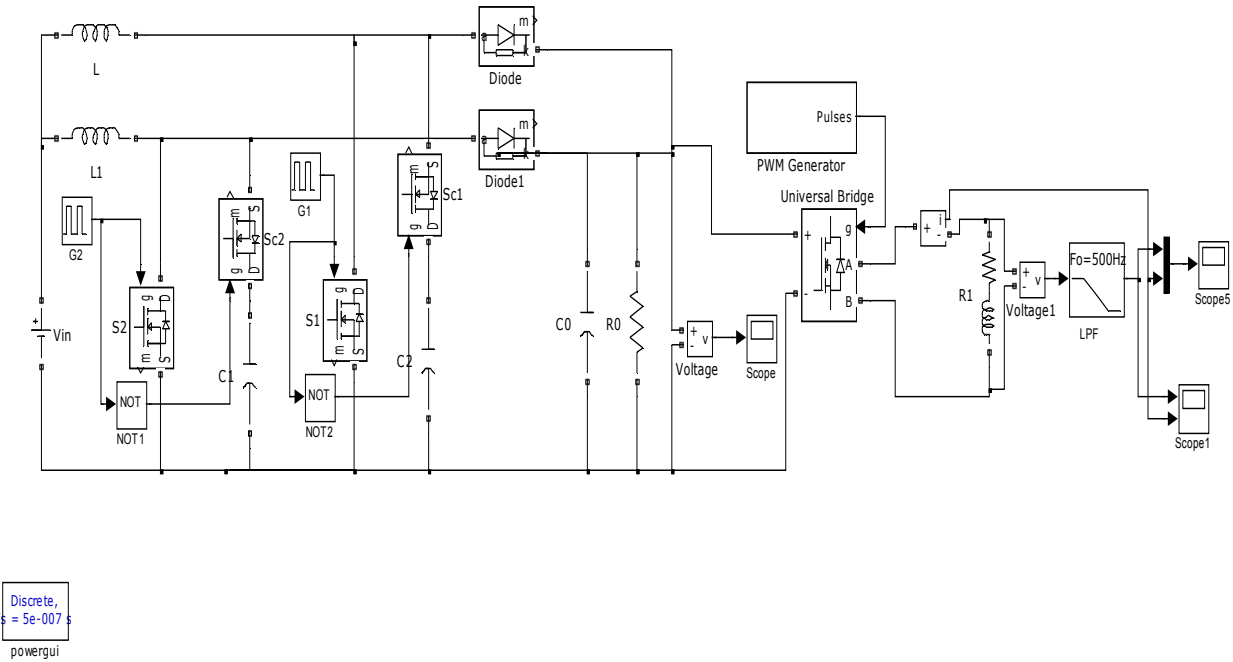

Fig. 6: Open loop operation of an ISSBC with full bridge bidirectional inverter

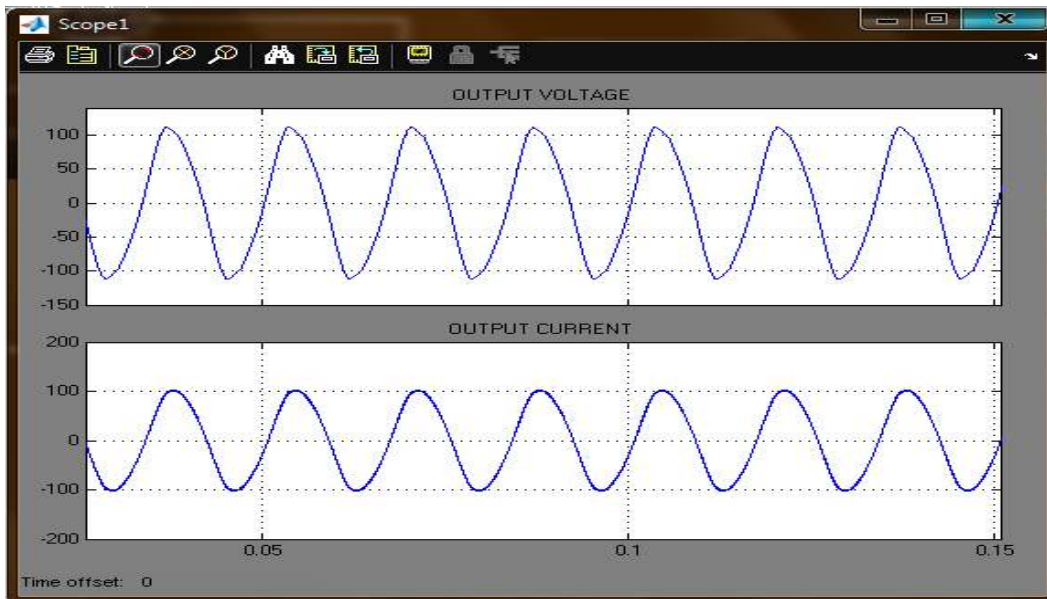

Fig. 7: Waveforms for output current and output voltage for open loop operation

power generation using PV array”. Figure 6 shows the open loop simulation diagram of proposed system. The waveform in Fig. 7 and 8 shows the output voltage and output current of proposed methodology under open loop operation of the circuit. Figure 9 shows the closed loop simulation diagram of proposed system. The waveforms in Fig. 10 and 11 show the output voltage and output current of proposed methodology under

closed loop operation. The waveform shows that the output voltage and current bringing together to the grid voltage and current.

Circuit description:

- Inductor-200 mF
- Capacitor-2.2 mF, 2.2 nF

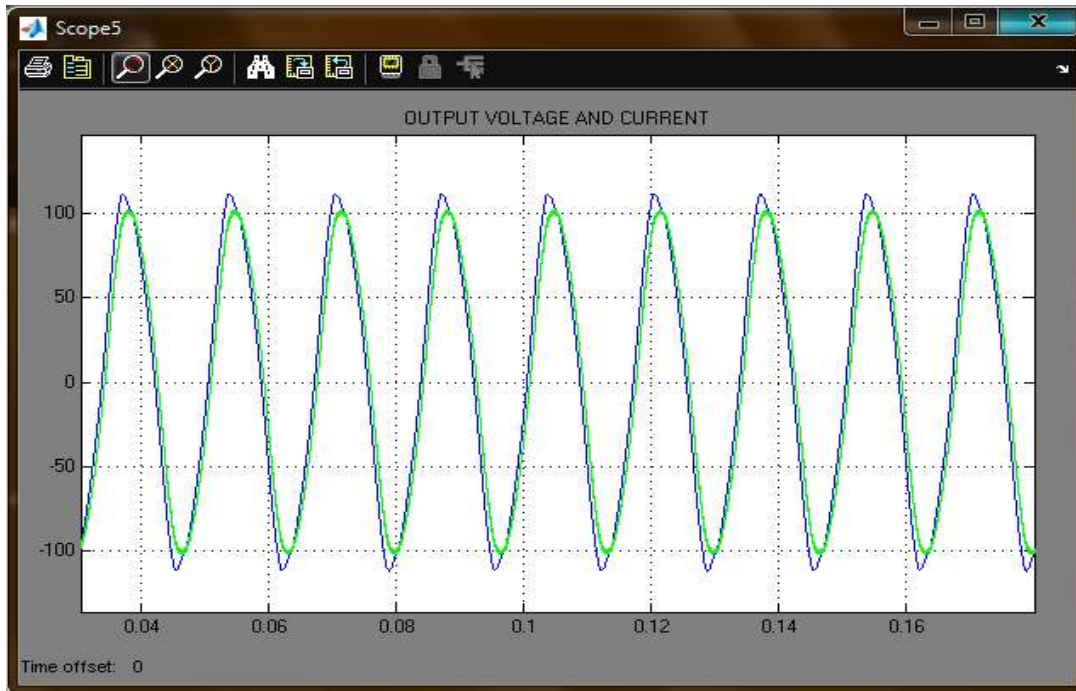

Fig. 8: Waveforms for output current and output voltage for open loop operation

Closed loop simulation diagram and results

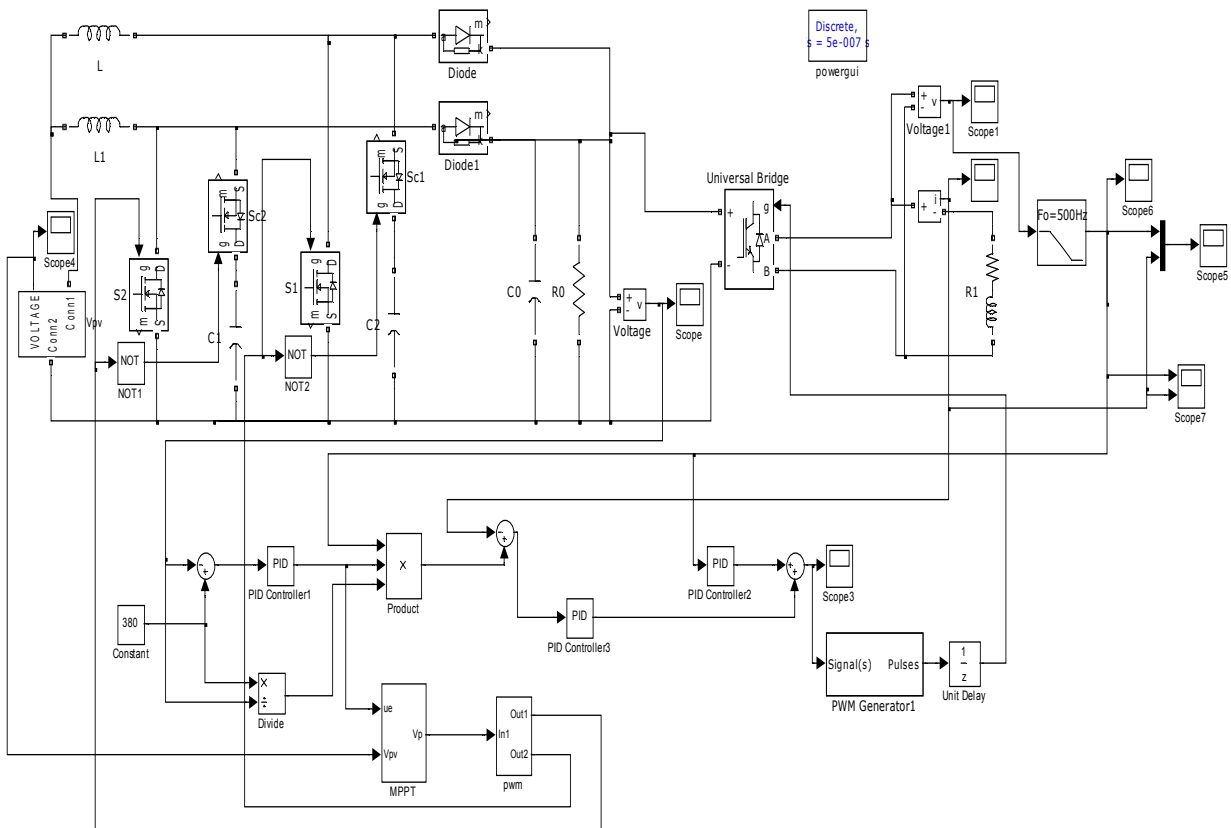

Fig. 9: Closed loop operation of an ISSBC with full bridge bidirectional inverter

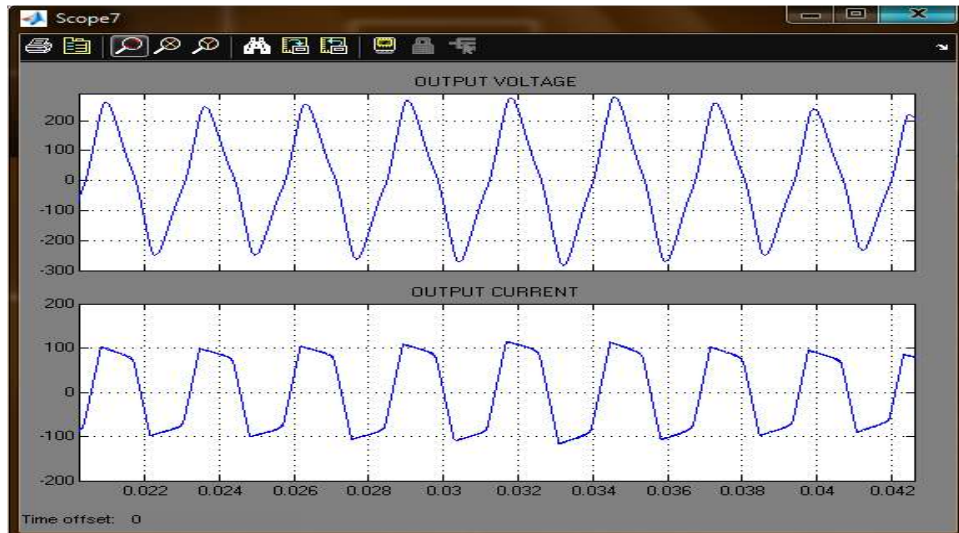

Fig. 10: Waveforms for output current and output voltage closed loop operation

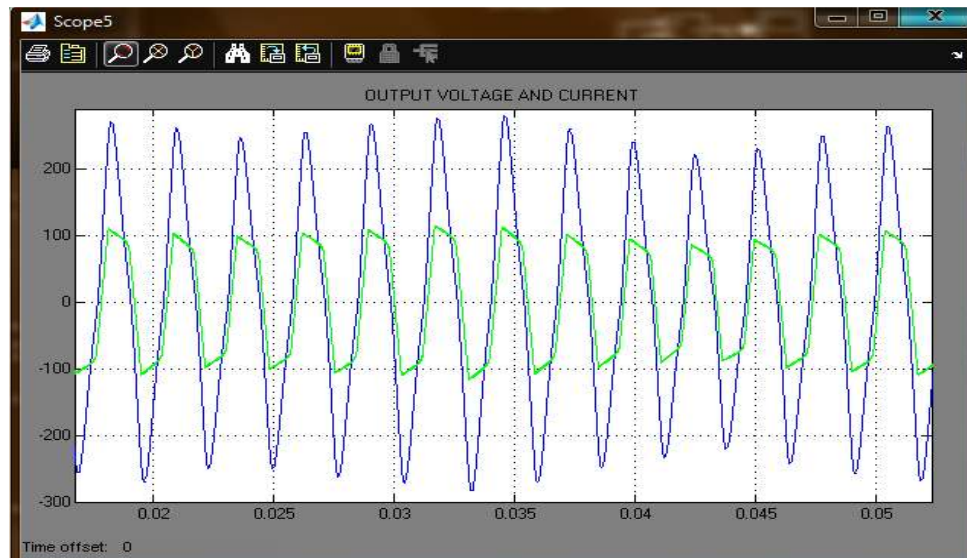

Fig. 11: Waveforms for output current and output voltage for closed loop operation

Diode-1N4007, 1N5408
 Regulator IC's-7805, 7812
 Resistor-10K, 47 ohm, 470 ohm
 Mosfet Driver-IR2112
 MOSFET-IR840
 Controller- PIC 16F877A
 PV Panel-12V

CONCLUSION

This study presented a “Photovoltaic Power Generation using an interleaved soft switching Boost converter with bidirectional full bridge inverter”. Interleaved soft switching boost converter is used to reduce the switching losses and the voltage gain is improved by using the coupled inductors. Compared to conventional hard switching technique the efficiency of

the system is improved in the soft switching method. The stabilization of voltage is obtained by the bidirectional full bridge PWM inverter. The open loop and closed loop operation of the system is verified by the simulation results. The voltage stresses in the switching devices were minimized in this method. MPPT control also performed to maximize the efficiency even under irradiance conditions.

REFERENCES

Bin, S. and L. Zhengyu, 2010. An interleaved totem-pole boost bridgeless rectifier with reduced reverse-recovery problems for power factor correction. IEEE T. Power Electron., 25(6): 1406-1415.

- Carbone, R., 2009. A passive MPPT technique for grid-connected photovoltaic systems. Proceeding on the 20th International Conference and Exhibition on Electricity Distribution-Part 1 (CIRED 2009), Prague, Czech Republic, pp: 1-4.
- Choi, W.Y., J.M. Kwon and B.H. Kwon, 2008. Bridge less dual-boost rectifier with reduced diode reverse-recovery problems for power-factor correction. *IET Power Electron.*, 1(2): 194-202.
- Chok-You, C., 2002. Analysis and passivity-based control of zero-voltage-transition PWM converters. *IEEE T. Power Electron.*, 17(5): 633-640.
- Da Silva, E.S., L. Dos Reis Barbosa, J.B. Jr Vieira, L.C. De Freitas and V.J. Farias, 2006. An improved boost PWM soft-single-switched converter with low voltage and current stresses. *IEEE T. Ind. Electr.*, 48(6): 1174-1179.
- De Oliveira Stein, C.M., H.A. Grundling, H. Pinheiro, J.R. Pinheiro and H.L. Hey, 2004. Zero-current and zero-voltage soft-transition commutation cell for PWM inverters. *IEEE T. Power Electron.*, 19(2): 396-403.
- Dos, R.B.L., J.B. Jr Vieira, L.C. de Freitas and V.J. Farias, 2001. An improved boost PWM soft-single-switched converter with low voltage and current stresses. *IEEE T. Indus Electron.*, 48(6): 1174-1179.
- Han, B.M., L. Jun-Young and J. Yu-Seok, 2010. Power conditioning system for fuel cell with 2-stage DC-DC converter. Proceeding of the IEEE 25th Annual Applied Power Electronics Conference and Exposition (APEC), Palm Springs, CA, pp: 303-308.
- Kazmierkowski, M.P. and L. Malesani, 1998. Current control techniques for three-phase voltage-source PWM converters: A survey. *IEEE T. Ind. Electr.*, 45(5): 691-703.
- Lee, J., B. Han and K. Choi, 2011. High-efficiency grid-tied power conditioning system for fuel cell power generation. Proceeding of the IEEE 8th International Conference on Power Electronics and ECCE Asia (ICPE and ECCE), Jeju, pp: 1492-1497.
- Lee, J.P., B.D. Min, T.J. Kim, D.W. Yoo and J.Y. Yoo, 2009. Design and control of novel topology for photovoltaic dc/dc converter with high efficiency under wide load ranges. *J. Power Electron.*, 9(2): 300-307.
- Li, W., W. Li and X. He, 2011. Zero-voltage transition interleaved high step-up converter with built-in transformer. *IET Power Electron.*, 4(5): 523-531.
- Qiang, F., 2012. Research on MPPT technique in photovoltaic power generation system. Proceeding of the International Conference on Computer Science and Electronics Engineering (ICCSEE), Hangzhou, 3: 394-398.
- Rong-Jong, W., L. Chung-You, D. Rou-Yong and C. Yung-Ruei, 2007. High-efficiency DC-DC converter with high voltage gain and reduced switch stress. *IEEE T. Indus Electr.*, 54(1): 354-364.
- Tseng, S.Y., C.L. Ou, S.T. Peng and J.D. Lee, 2009. Interleaved coupled-inductor boost converter with boost type snubber for PV system. Proceeding of the IEEE Energy Conversion Congress and Exposition, San Jose, CA, pp: 1860-1867.
- Zitao, W., 2009. A hybrid control method for three-phase grid-connected inverters with high quality power. Proceeding of the IEEE Energy Conversion Congress and Exposition (ECCE 2009), San Jose, CA, pp: 17-24.