

Research Article

Logic Threshold Based Energy Control Strategy for Parallel Hydraulic Hybrid Vehicles

Liu-Tao, Zheng-Jincheng, Wang-Shuwen and Gu-Fangde

School of Automotive Engineering, Harbin Institute of Technology at Weihai, China

Abstract: To improve the performance of a Parallel Hydraulic Hybrid Vehicle (PHHV), the operation of components in the hydraulic hybrid system of the vehicle should be well coordinated. This study introduces an energy control strategy based on the logic threshold methodology for PHHVs. The energy distribution of the PHHV can be controlled in real-time and the operation modes of the PHHV can be changed dynamically by means of this energy control strategy. A simulation model for the analysis of the whole vehicle dynamic performance is developed using the Simulink in MATLAB. The multi-objective Genetic Algorithm (GA) optimization method is employed to get the optimal working modes, the best energy distribution in different drive cycles and the optimal parameters of the control strategy. In this optimization, maximum fuel economy is the objective and the difference of engine optimal torque and active pressure torque and the pressure limit are the variables of the GA optimization. The simulation results show that the fuel economy of the PHHV can be improved and in addition, the dynamic performance of the vehicle can be enhanced with the proposed energy control strategy.

Keywords: Energy control strategy, genetic algorithm optimization, hydraulic hybrid vehicle, simulation

INTRODUCTION

With the development of hybrid technology, the Hydraulic Hybrid Vehicle (HHV) has attracted more and more attention from governments, research institutions and automobile manufacturers. Compared with electric hybrid technology, hydraulic hybrid technology is more competitive in the medium/heavy vehicles and construction machinery sector because a hydraulic accumulator has the advantages of high power density, fast energy charge and discharge and high efficiency of energy recovery. However, for the HHV it is very difficult to achieve the desired energy-saving objective using the conventional control strategies, because the hydraulic accumulator has some drawbacks: its energy density is low; it is unable to provide auxiliary energy for long periods; the coordination among various components of a hybrid system is complex; and it is difficult to develop accurate mathematical models.

The energy control strategy is critical to the Parallel Hydraulic Hybrid Vehicles (PHHV). Currently, there are mainly three energy control strategies for Parallel Hydraulic Hybrid Vehicles (PHHV), namely logic threshold, fuzzy logic and global optimization. The logic threshold method is widely used in the energy control strategy, because it is fast, simple and practical as mentioned in Pu *et al.* (2005) and Buchwald *et al.* (1979) proposed three different

control strategies based on the characteristics of an engine under static conditions. Wu *et al.* (2004) based on the results of dynamic programming, proposed a logic threshold based energy control method that improved the study efficiency of the hydraulic pump/motor, but ignored the efficiency issue when the engine was used by its own, so that the improvement of fuel economy of the PHHV is limited. In this study, a new energy control strategy is proposed based on the logic threshold method. By means of the control strategy, the operating modes in the hybrid system can be changed and the torque distribution between engine and hydraulic pump/motor can be properly controlled according to the demanded torque. The parameters in the control strategy are optimized and the vehicle performance is simulated using Simulink in MATLAB. The simulation results show that the new energy control strategy, based on the logic threshold, can significantly improve the fuel efficiency.

CONFIGURATION OF A PHHV

Figure 1 illustrates the configuration of a PHHV. This rear-wheel-drive hydraulic hybrid vehicle primarily consists of an internal combustion engine, a high pressure accumulator, a low pressure reservoir and a variable displacement hydraulic pump/motor unit. The primary power source is the same diesel engine as that used in a conventional vehicle. The transmission

Corresponding Author: Liu-Tao, School of Automobile Engineering, Harbin Institute of Technology at Weihai, 2 West Wenhua Road, Weihai City, Shandong 264209, China

This work is licensed under a Creative Commons Attribution 4.0 International License (URL: <http://creativecommons.org/licenses/by/4.0/>).

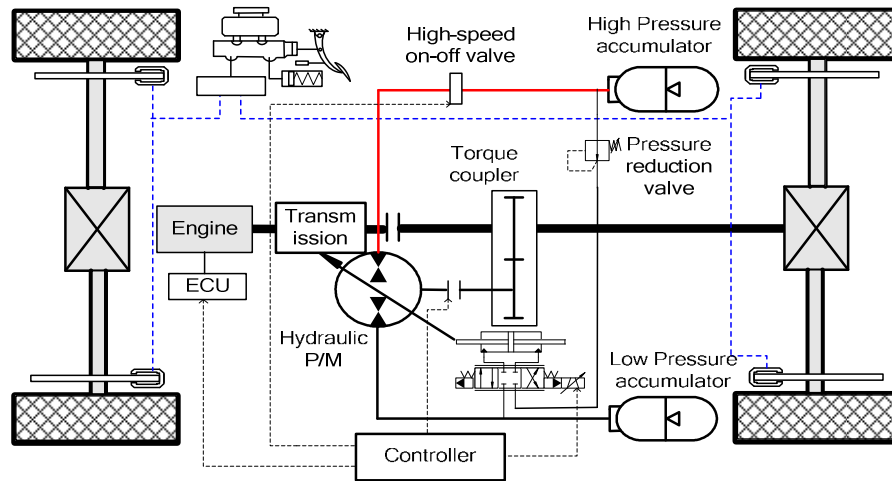

Fig. 1: Configuration of a PHHV

Table 1: Parameters of the vehicle

Vehicle:	
Wheel radius	0.5 m
Rolling resistance	0.02
Aerodynamic drag coefficient	0.65
Frontal area	6.5 m ²
Total vehicle mass	14310 kg

Table 2: Parameters of main components of the vehicle

Accumulator system:	Volume	63L	
	Max working pressure	35 MPa	
	Min working pressure	18 MPa	
Transmission	Gear ratio	6.62, 3.99, 2.47, 1.55, 1	
		Main gear ratio	4.85
	Torque coupler ratio		1.2
	Hydraulic pump/motor	Type and displacement	A4VG90
Max Torque		572 Nm	

and power-train are also the same as those in the conventional vehicle. The hydraulic pump/motor is coupled with the transmission shaft via a torque coupler. The parameters of the vehicle and its main components are shown in Table 1 and 2, respectively.

LOGIC THRESHOLD BASED ENERGY CONTROL STRATEGY

A hydraulic accumulator has the characteristics of high power density but low energy density, so that the control strategy of a hydraulic accumulator is entirely different from other hybrid vehicles such as Hybrid Electric Vehicles (HEVs). The logic threshold based energy control strategy is primarily based on the efficiency curve of the engine to smoothly change the working modes according to the required power of the hybrid system and the real-time parameters of the vehicle, to properly control the torque distribution between the engine and the hydraulic pump/motor and to ensure that the engine operates in the best energy saving mode, as discussed in Zhang *et al.* (2007),

Mukhitdinov *et al.* (2006) and Huang *et al.* (2008).

The selection of logic threshold parameters and changing of working modes: In the energy control strategy of a PHHV, the optimal working state of the engine is defined according to the required torque and the working objective of the engine is that the engine output torque T_{e-opt} corresponds to the engine best economic curve. The difference of T_{e-opt} and the required torque T_{req} is defined as ΔT that is the threshold of active-pressure-charging, while the limit of active-charging-pressure of the hydraulic accumulator p_c is another threshold in the PHHV energy control strategy. Figure 2 shows the principle of the logic threshold based energy control strategy.

During the start-up of the PHHV, if the pressure of the hydraulic accumulator is greater than the minimum working pressure p_{min} , so the driving torque is supplied by the hydraulic pump/motor only. If the pressure of the hydraulic accumulator is less than the active-charging-pressure p_c and $T_{e-opt} - T_{req} > \Delta T$, the hydraulic pump/motor charges the accumulator to make the engine work towards a state of best fuel economy and if the pressure of hydraulic accumulator reaches the limit of the active-charging-pressure p_c , the hydraulic pump/motor works only. When $T_{req} > T_{e-opt}$, both the hydraulic pump/motor and the engine provide driving torques and the output power of the hydraulic pump/motor depends on the pressure of the hydraulic accumulator.

The hydraulic accumulator has excellent affordability of duty cycle and life and it can work efficiently in the whole working pressure range. The changing of the working modes of the energy control strategy depends primarily on the required torque T_{req} , the current vehicle speed v , the current pressure p of the hydraulic accumulator, ΔT (the difference of engine optimal output torque T_{e-opt} and the required torque

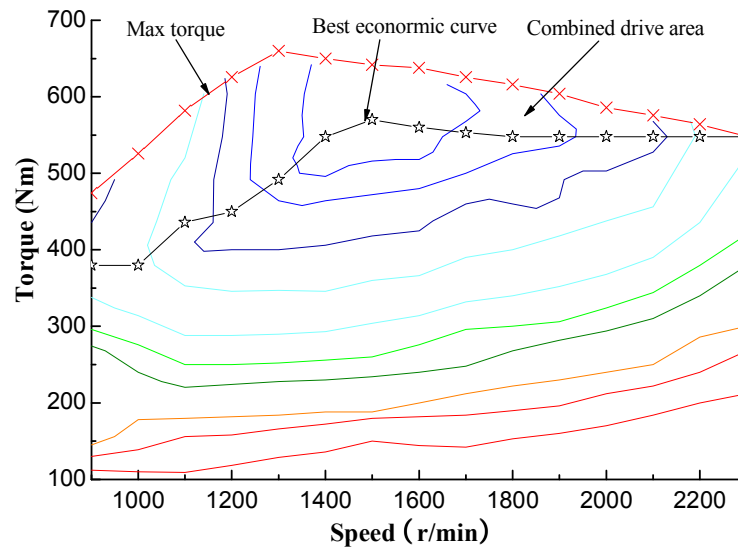

Fig. 2: Energy control strategy based on the logic threshold

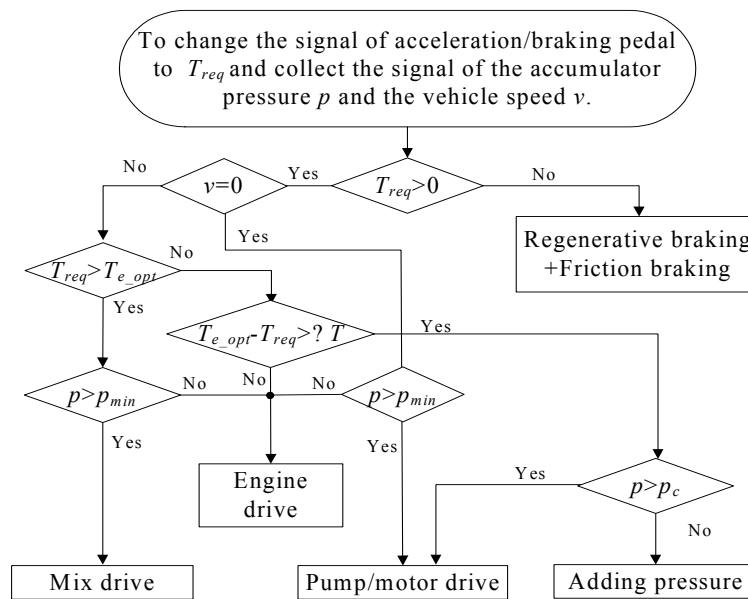

Fig. 3: Flow chart of the change of working modes

T_{req}) and other threshold parameters. The flow chart of the change of working modes is shown in Fig. 3.

Implementation of the logic threshold based energy control strategy: Based on the above mentioned methods, suitable logic threshold parameters can be determined. In the vehicle real-time operation, the logic threshold based energy control strategy transforms signals from the acceleration and braking pedals into the required torque of the hybrid system and selects the proper working mode according to the required torque and the established logic threshold parameters of the hybrid system. The highest vehicle efficiency and energy recovery can be achieved by adjusting the

torque and speed of the engine and the hydraulic pump/motor to ensure that they work at high efficiency with the energy control strategy.

OPTIMIZATION OF LOGIC THRESHOLD PARAMETERS

Simulation model of vehicle: In order to verify the proposed energy control strategy, the PHHV backward simulation model is developed using the Simulink in MATLAB, which is demonstrated in Fig. 4. The hybrid system control unit mainly includes the energy reuse strategy mentioned in this study and other basic strategies, such as hydraulic regenerative braking

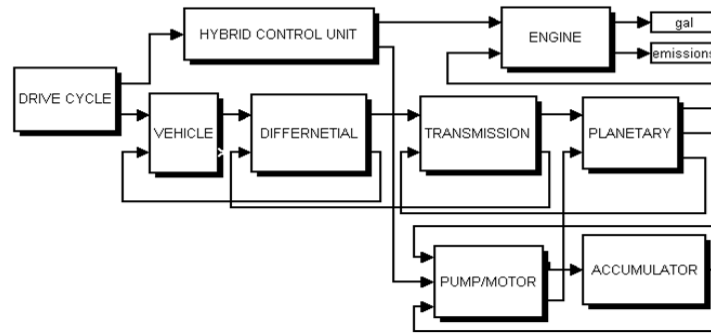

Fig. 4: Backward simulation model of PHHV

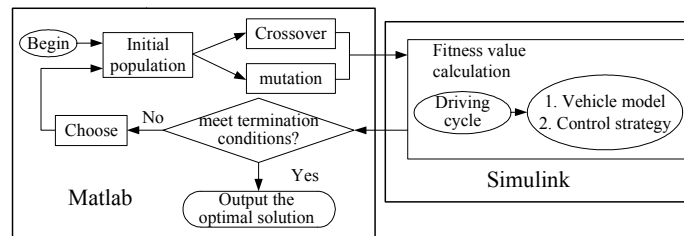

Fig. 5: Flow chart of optimization simulation model based on GA

strategy that has been discussed by Liu *et al.* (2009). The basic parameters of the PHHV used for the study are shown in Table 1 and 2 above.

Optimization of logic threshold parameters: Because the torque difference of active-charging-pressure ΔT and the pressure limit of active-charging-pressure p_c are the critical parameters in the control strategy of PHHVs and these parameters significantly affect the fuel economy of PHHVs, they are optimized by means of the genetic algorithms.

In the genetic optimization, the genetic algorithm is compiled to MATABL files, then these files are called to complete the genetic steps required to generate the initial population, selection, crossover and mutation for the parameters ΔT and p_c of the logic threshold control strategy to implement the optimization. The objective function and constraints are calculated based on the vehicle simulation model using the SIMULINK in MATLAB. The flow chart of optimization simulation of the parameters of the control strategy is shown in Fig. 5. The simulation model as a module is embedded into the entire optimization procedure for implementation, the evolution is based on dynamic simulation and it is completed in the time domain. For each individual in each generation, the optimal solution is obtained from a complete drive-cycle using the full-vehicle simulation model.

ΔT and p_c were two parameters of the control strategy to be optimized and each parameter to be optimized was a gene in the genetic optimization. A

Table 3: Design variables and their upper and lower limits in the genetic optimization

Design variables	ΔT	p_c
Symbols	x_1	x_2
Unit	N.m	MPa
Lower limit	70	20
Upper limit	420	32

variable was expressed using a binary genes encoding with a fixed length of eight numbers and a chromosome was formulated by ΔT and p_c , representing a solution, namely $x = (\Delta T, p_c)$. The design variables and their upper and lower limits of the logic threshold control strategy are shown in Table 3.

The proportional roulette selection strategy was used for the selection and the individual probability of being selected was $f_{x,i} / \sum_{i=1}^n f_{x,i}$, where $f_{x,i}$ was the fitness of individual i . In the genetic algorithm, the entire group was partitioned by each individual and the ratio of the fitness function value of each individual to the total fitness function value was different. These individual ratio values divided the entire gamble disk and they determined the probability of each individual to be inherited to the genetic offspring group. In the optimization, the crossover probability was chosen as 0.65 and mutation probability was chosen as 0.06, the number of initial population was set as 100 and the maximum number of iterations was determined as 100.

The NYCC drive-cycle was used in the optimization of the control strategy parameters of the hydraulic hybrid vehicle. The objective of optimization was the fuel consumption and the optimization process is shown in Fig. 6. It can be seen in Fig. 6 that the best

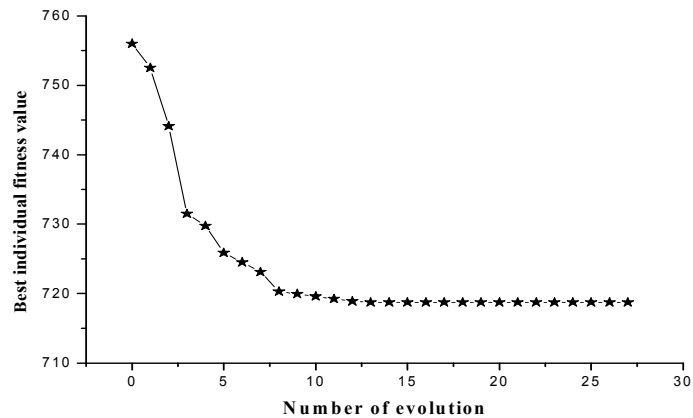

Fig. 6: Optimization process

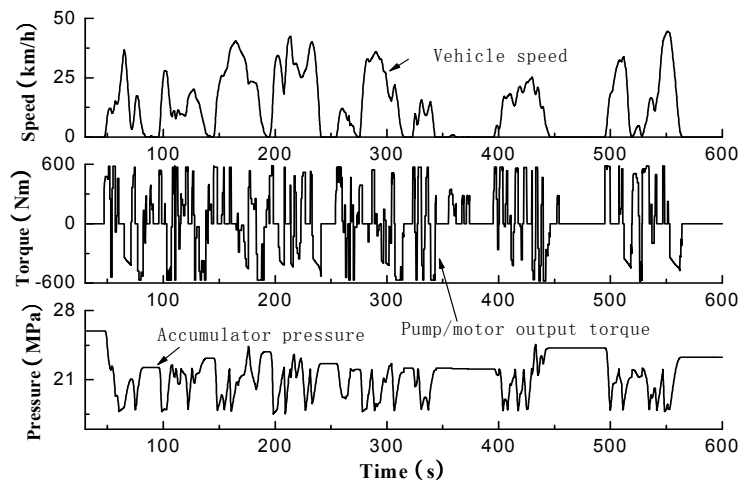

Fig. 7: Simulation results with the energy control strategy

Table 4: Fuel consumption before and after optimization

Drive-cycle	Fuel consumption before optimization	Fuel consumption after optimization	Improvement
NYCC	747.85(g)	718.76(g)	3.89%

individual fitness in the initial evolution was decreased with the increasing of generation evolution and its convergence speed was faster than that after 15 generations. The best fitness remained unchanged after 15 generations and the optimal values of the parameters of the control strategy were $\Delta T = 362.8\text{Nm}$ and $p_c = 25.6\text{MPa}$.

The fuel consumption before and after the optimization are shown in Table 4, which shows that the fuel economy has been improved 3.89%.

SIMULATION RESEARCH

To validate the effectiveness of the energy control strategy based on the logic threshold, the simulation was implemented using the backward model of the parallel hydraulic hybrid vehicle in the urban driving cycle NYCC. With standard driving conditions the

energy efficiency of the energy control strategy can be more objectively tested. The parameters of the control strategy were $\Delta T = 362.8\text{Nm}$ and $p_c = 25.6\text{MPa}$. The important parameters of the PHHV are shown in Table 1 and 2 above.

Figure 7 shows the simulation results using the energy control strategy with the logic threshold. When the pressure of the hydraulic accumulator was higher than the minimum working pressure, the engine was turned off and the vehicle was driven by the hydraulic pump/motor only, so that the fuel consumption was relatively low. When the engine was turned on, the hydraulic pump regulated the loading ratio of the engine through actively charging the accumulator. The large pressure fluctuation of the accumulator shown in Fig. 7 indicated that the energy was effectively recovered and re-used.

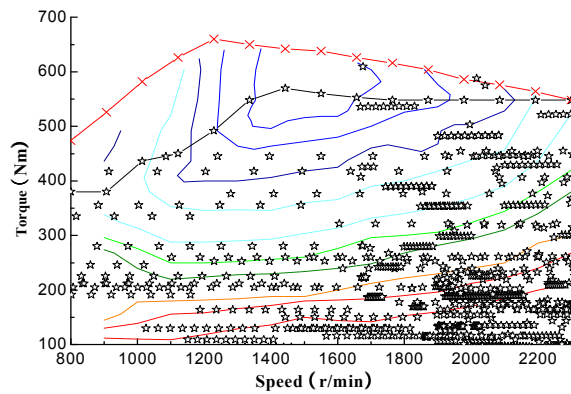

Fig. 8: Traditional engine operation maps

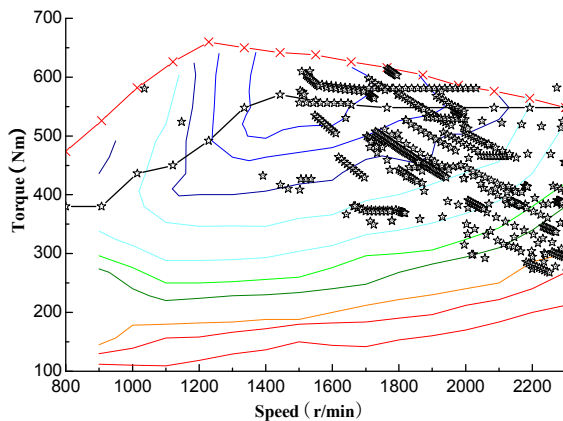

Fig. 9: Engine operation maps with energy control strategy

Figures 8 and 9 show the operational distribution maps of the traditional and PHHV engine, respectively. It can be seen clearly from these two figures that by means of the logic threshold based energy control strategy, most of the time the engine worked at the high efficient region at high engine rotating speed with high output torque. This verified that the energy control strategy was capable of controlling the engine to work at high efficiency.

Table 5 lists the simulation results of the fuel saving rate and power performance of a traditional vehicle and the PHHV in NYCC drive-cycle. Comparing with the similar traditional vehicle, the PHHV with energy control strategy can effectively increase the fuel economy and improve the main power performance of the vehicle.

CONCLUSION

Based on the engine efficiency map and hydraulic pump/motor efficiency curve, the logic threshold based energy control strategy was developed to control the energy distribution of a hybrid system in real-time and to implement the dynamic change of working modes in a hybrid system. The logic thresholds were optimized with the objective of maximum energy saving. The

Table 5: Simulation results of fuel saving rate and power performance of the vehicle

	Traditional vehicle	Hydraulic hybrid vehicle
Fuel saving rate (%)		32.4
Max grade ability (%)	30	30.5
Max driving force (kN)	42	58.7

simulation results using the Simulink in MATLAB verified that the working modes of a hybrid system can be effectively changed by means of the logic threshold based energy control strategy. With the logical thresholds optimized using a genetic algorithm, the dynamic performance of the PHHV can be improved and the fuel consumption can be effectively reduced by means of the energy control strategy. This can be used for off-line parametric optimization and thus shorten the calibration time of a vehicle controller.

ACKNOWLEDGMENT

This study was supported by the Natural Science Foundation of Shandong Province under the project no. ZR2009FL002.

REFERENCES

- Buchwald, P., H. Christensen, H. Larsen and P.S. Pedersen, 1979. Improvement of Citybus Fuel Economy Using a Hydraulic Hybrid Propulsion System—a Theoretical and Experimental Study. SAE Paper No. 790305, Doi: 10.4271/790305.
- Huang, Y.J., C.L. Yin and J.W. Mang, 2008. Development of the energy management strategy for parallel hybrid electric urban buses. Chin. J. Mech. Eng., 21(4): 44-50.
- Liu, T., J. Jiang and H. Sun, 2009. Research on the regenerative braking control strategy for parallel hydraulic hybrid vehicle based on backward modeling. China Mech. Eng., 20(15): 1880-1884. (In Chinese)
- Mukhitdinov, A.A., S.K. Ruzimov and S.L. Eshkabilov, 2006. Optimal control strategies for CVT of the HEV during a regenerative process. Proceedings of IEEE Conference on Electric and Hybrid Vehicles. Pune, India, pp: 1-12.
- Pu, J., J. Yan, C. Yin, J. Zhang and Z. Zhu, 2005. Investigation to the simulation of control strategy of parallel hybrid electric vehicles. J. Syst. Simul., 17(7): 1543-1547. (In Chinese)
- Wu, B., C. Lin, Z. Filipi, H. Peng and A. Dennis, 2004. Optimal power management for a hydraulic hybrid delivery truck [J]. Vehicle Syst. Dyn., 42(1): 23-40.
- Zhang, C., J. Wu and N. Cui, 2007. Energy management strategy of parallel hybrid electric vehicle with continuously variable transmission. Chin. J. Mech. Eng., 43(10): 114-118. (In Chinese)