

Research Article

Accurate THD Formulas for Multilevel Inverters with MILP Optimization

Mahmoud El-Bakry

Electronics Research Institute, Egypt

Abstract: This study aims to derive simple formulas for calculating the accurate Total Harmonic Distortion (THD) of Multilevel Inverter (MLIs), that considers all low and high order harmonics, for single phase and three phase MLIs., since the THD is a main criterion when judging the performance of a MLI. In addition, a formula for the percentage route mean square value of high order harmonics $\%V_{HO_{rms}}$ is derived. These formulas could be applied for all types of MLIs that use different switching techniques for harmonics elimination or reduction, so long as the switching angles of the phase voltage are known and it is specially suitable to be applied with the Mixed Integer Linear Programming (MILP) optimization model, which is constructed for determining the switching angles of the MLI that minimize the absolute values of any undesired harmonics. This study aims also to show that this MILP model can produce solutions that have low values of the accurate THD, by giving the detailed solutions of two cases taken from the references.

Keywords: Accurate Total Harmonic Distortion (THD), harmonic values minimization, Mixed Integer Linear Programming (MILP), multi-level inverters

INTRODUCTION

The Multilevel Inverter (MLI) has recently replaced the conventional inverter, due to its multilevel output voltage that can approach more closely a sine wave shape (Sing *et al.*, 2012). MLIs are covering now many practical applications, such as for the control of ac electric drives (Dixon *et al.*, 2010; Ge *et al.*, 2010; Khoucha *et al.*, 2011), for photovoltaic systems (Cecati *et al.*, 2010; Rahim *et al.*, 2011), for high power ac grid (Gultekin *et al.*, 2012) and more recently for renewable energy and smart grid integration (Wanjekeche *et al.*, 2011; Zhong and Hornik, 2012). Many types of MLIs have been developed (Malinowoki, 2010), which emerge mainly from three main types: diode clamped MLIs, flying capacitors MLIs and cascaded MLIs. Figure 1 shows, two examples of MLIs, a flying capacitor MLI and a general single phase cascaded MLI with unequal dc sources.

Figure 2 shows the waveforms of the output voltage produced by the flying capacitor MLI of Fig. 1a and by a seven level single phase cascaded MLI. The output voltage waveform of a MLI generally approaches a sine waveform, but still consists of many undesired harmonics.

A fundamental issue for a CMLI is to find the switching angles (times) of the inverter H-bridges semiconductor power switches that produce the required fundamental voltage and at the same time eliminate or reduce the values of undesired specific low order dominant harmonics. Many methods are given in the literature for obtaining the switching angles of CMLIs. These are mainly:

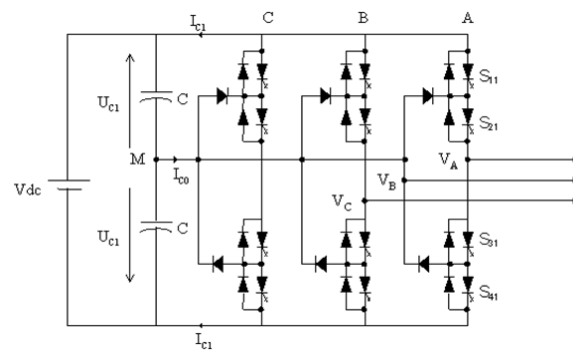

(a) A flying capacitor MLI

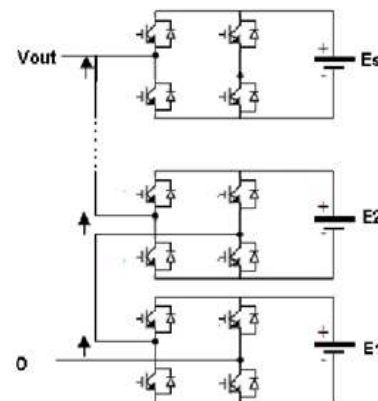

(b) A general single phase cascaded MLI

Fig. 1: Examples of MLIs

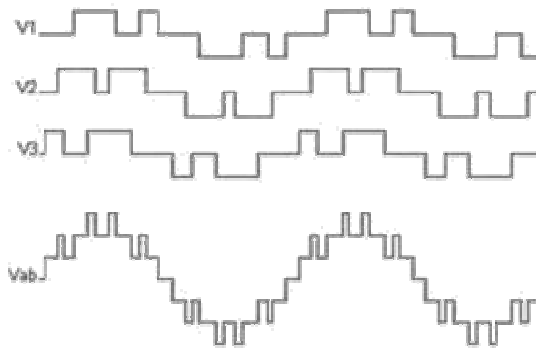

(a) The line voltage of the flying capacitor MLI of Fig. 1a

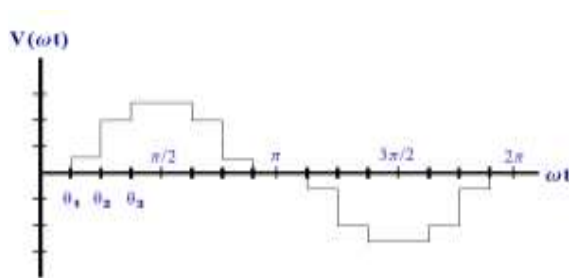

(b) The output voltage of a seven-level cascaded MLI

Fig. 2: Examples of the output waveform of MLIs

- Using sinusoidal pulse width modulation (Carnielutti *et al.*, 2012; Leon *et al.*, 2011; Seyezhai and Mathur, 2010; Sujanarko *et al.*, 2010)
- Using a selective harmonic elimination technique, where the zero equations of the undesired harmonics with the equation of the desired amplitude of the main harmonic as functions of the switching angles are solved directly or by applying genetic algorithms (Ahmadi *et al.*, 2010; El-Hamrawy *et al.*, 2010; Filho *et al.*, 2013; Kavousi *et al.*, 2012; Napoles *et al.*, 2013)
- Using the method of minimizing the total harmonic distortion (Kumar *et al.*, 2009; Yousefpoor *et al.*, 2012)

In addition, the author has introduced an optimization method based on applying a Mixed Integer Linear Programming (MILP) optimization model to determine the switching angles that minimize the values of any undesired harmonics (El-Bakry, 2009, 2010).

In all these methods, low order harmonics are mainly considered and high order harmonics are not taken into consideration. However, it may be not enough to consider eliminating or reducing low order harmonics. It is important to know the amount of all the harmonics of the MLI, since high order harmonics lead to additional losses and may cause disturbances and need additional filtering.

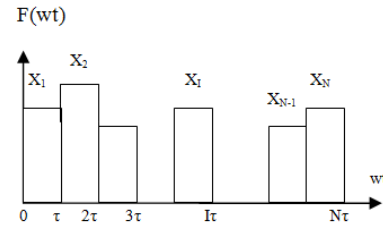

Fig. 3: Representation of $F(wt)$ by X_i , $i = 1, 2, \dots, N$ over the interval $0 \leq wt \leq \pi/2$

Actually, the IEEE standard for voltage distortion limits in power systems IEEE Standard 519-1992 (1993) put limits on the exact THD of power systems., which assures the importance of knowing the exact THD of MLIs., which considers both low order and high order harmonics produced .

In this study, simple formulas are derived for calculating the exact THD, which are simpler than that given by Farokhnia *et al.* (2011) and for calculating the route mean square (rms) value of high order harmonics. $V_{HO_{rms}}$. Two cases are considered, single phase MLI and three phases MLI. The derivation of these formulas depends on the same idea used by the author when applying a MILP model for determining the switching angles of the MLI. This idea depends on dividing the time interval of the output voltage into small equal subintervals such that a certain voltage level is associated with each subinterval. The derived formulas of the exact THD could be applied directly to the solution of the MILP model. Two cases taken from the references are analyzed and show low values of the obtained exact THD.

DERIVING A FORMULA FOR CALCULATING THE EXACT THD OF A SINGLE PHASE MLI

The general output voltage wave form $F(wt)$ of a single phase MLI has a quarter wave symmetry, as that shown in Fig. 2. The pattern of this function is generated by on and off switching of the inverter H-bridges semiconductor power switches and is completely determined by defining the switching pattern over the interval $0 \leq wt \leq \pi/2$. The basic approach depends on dividing this interval into N equal small subintervals, starting at the angles $0, \tau, 2\tau, \dots, (I-1)\tau, \dots$ till $(N-1)\tau$, where, $\tau = \pi/2N$, Fig. 3.

It is assumed that a single voltage level is associated with each subinterval. The positive values X_i , $i = 1, 2, \dots, N$ are defined over each subinterval, to represent the instantaneous output voltage level value $F(wt)$ of the inverter, so that $F(wt)$ is defined over the interval $0 \leq wt \leq \pi/2$ by:

$$F(wt) = X_i$$

$$\text{for } (I-1)\tau \leq wt \leq I\tau \text{ and } I=1,2,\dots,N$$

The Fourier series expansion of $F(wt)$ is an odd – sines series given by :

$$F(wt) = \sum_{m=0}^{m=\infty} V_{2m+1} \sin(2m + 1)wt. \tag{1}$$

The THD is usually calculated till a specific harmonic of order $2k+1$ using the expression:

$$THD_{2k+1} = \sqrt{\frac{\sum_{m=1}^{m=k} V_{2m+1}^2}{V_1^2}} \tag{2}$$

The exact THD must include all the harmonics as given by:

$$THD = \sqrt{\frac{\sum_{m=1}^{m=\infty} V_{2m+1}^2}{V_1^2}} \tag{3}$$

The values of the amplitudes of the main harmonic V_1 and the subsequent harmonics V_{2k+1} could be replaced by their root mean square (rms) values, getting:

$$THD = \sqrt{\frac{\sum_{m=1}^{m=\infty} V_{(2m+1)rms}^2}{V_{1rms}^2}} \tag{4}$$

The rms value of the output voltage V_{rms} is given by:

$$V_{rms} = \sqrt{\sum_{m=0}^{m=\infty} V_{(2m+1)rms}^2} \tag{5}$$

The expression for the exact THD is thus:

$$THD = \sqrt{\frac{V_{rms}^2}{V_{1rms}^2} - 1}. \tag{6}$$

The value of V_{rms} is obtained from the waveform shape of the output voltage, referring to Fig. 3 and is given by:

$$V_{rms}^2 = (1 / 2\pi) \int_0^{2\pi} F^2(wt) dwt.. \tag{7}$$

Due to the quarter wave symmetry of $F(wt)$, the value of V_{rms} could be obtained from the first quarter half cycle:

$$V_{rms}^2 = (1 / N) \sum_{l=1}^{l=N} X_l^2 \tag{8}$$

The expression for the exact THD is thus given by:

$$THD = \sqrt{\frac{\sum_{l=1}^{l=N} X_l^2}{NV_{1rms}^2} - 1..} \tag{9}$$

If the values of the exact THD and of the THD till the harmonic of order $2k+1$ THD_{2k+1} are determined, then the rms value of high order harmonics V_{HOrms} for the harmonic of order $2k+3$ till ∞ relative to V_{1rms} is obtained as follows:

And then:

$$\begin{aligned} V_{HOrms}^2 &= \sum_{m=2k+3}^{m=\infty} V_{(2m+1)rms}^2 \\ &= \sum_{m=0}^{m=\infty} V_{(2m+1)rms}^2 - \sum_{m=0}^{m=2k+1} V_{(2m+1)rms}^2 \\ V_{HOrms}^2 / V_{1rms}^2 &= THD^2 - THD_{2k+1}^2 \\ V_{HOrms} / V_{1rms} &= \sqrt{[THD^2 - THD_{2k+1}^2]} \end{aligned} \tag{10}$$

DERIVING A FORMULA FOR THE EXACT THD OF THE LINE VOLTAGE OF A THREE PHASE MLI

It is required to determine the exact THD of the line voltage of a three phase MLI, given the switching pattern of the phase voltage. Referring to the time orientation of phase voltages given in Fig. 4, let the instantaneous value of phase 1 be $F(wt)$, as defined by Fig. 3. The instantaneous value of a line voltage between phases 1 and 2 $F_L(wt)$ is given by:

$$F_L(wt) = F(wt) - F(wt - 2\pi / 3).. \tag{11}$$

From Eq. (1), the amplitude of the line voltage harmonic of order $2m+1$ is deduced to be:

$$\begin{aligned} V_{L(2m+1)} &= 0..... \text{for } 2m + 1 = 3, 9, 15, \dots, \infty \\ V_{L(2m+1)} &= \sqrt{3}V_{2m+1}..... \text{otherwise} \end{aligned}$$

The odd triplen harmonics, i.e., that correspond to $2m+1 = 3, 9, 15, \dots, \infty$ are self cancelled and this distinguishes the value of the THD of the line voltage from that of the phase voltage.

For calculating the THD of the line voltage and referring to time axis of Fig. 4, $F(wt)$ has a quarter wave symmetry, but $F(wt - 2\pi/3)$ and hence $F_L(wt)$

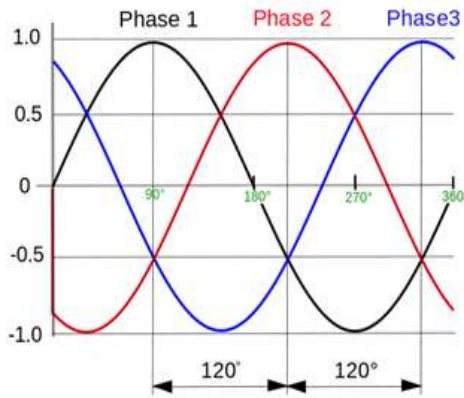

Fig. 4: Time orientation of three phase voltages

will have only half wave symmetry and thus value of V_{rms} of F_L is thus given by:

$$V_{rms}^2 = (1 / \pi) \int_0^{\pi} F_L^2 (wt) dwt. \quad (12)$$

To calculate the value of V_{rms} for $F_L (wt)$ using Eq. (12), the instantaneous time values of $F_L (wt)$ in terms of X_I must be considered over a half wave interval.

In the following derivation it will be assumed that the number of subintervals N is an integer multiple of 3, such that $N/3$ is an integer number.

The instantaneous values of phase 1 voltage over the first quarter cycle are given by $F (wt) = X_I$, for $I = 1, 2, \dots, N$.

The instantaneous values of phase 2 voltage $F (wt - 2\pi/3)$ over the first quarter cycle are given by Y_I , where the values of Y_I from $I = 1$ to $I = N/3$ equal the negative values of X_I from $1 + 2N/3$ to N , respectively. The values of Y_I from $N/3 + 1$ to N equal the negative values of X_I from N to $N/3$, respectively, i.e.:

$$\begin{aligned} Y_I &= -X_{(2N/3)+I} \text{ for } I = 1, 2, \dots, N/3 \\ Y_I &= -X_{(4N/3)-I} \text{ for } I = (N/3) + 1, \dots, N \end{aligned} \quad (13)$$

Dividing the time interval over the second quarter, that correspond to an angular value from $\pi/2$ to π , into N equal subintervals, as the first quarter interval, the following values are deduced:

The instantaneous values of phase 1 voltage over the second quarter cycle are $F (wt) = XX_I$, where:

$$XX_I = X_{2N+1-I} \text{ for } I = N + 1, \dots, 2N \quad (14)$$

While the instantaneous values of phase 2 voltage $F (wt - 2\pi/3)$ over the second quarter cycle is given by

YY_I , where the values of YY_I from $N+1$ to $4N/3$ equal the negative values of X_I from $N/3$ to 1, respectively. The values of YY_I from $4N/3 + 1$ to $2N$ equal the values of X_I from 1 to $2N/3$ respectively, i.e.:

$$\begin{aligned} YY_I &= -X_{(4N/3)+1-I} \text{ for } I = N + 1, \dots, 4N/3 \\ YY_I &= X_{I-(4N/3)} \text{ for } I = (4N/3) + 1, \dots, 2N \end{aligned} \quad (15)$$

The instantaneous values of the line voltage $F_L (wt)$ over the first half cycle are thus given by Z_I where:

$$\begin{aligned} Z_I &= X_I - Y_I \text{ for } I = 1, 2, \dots, N \\ Z_I &= XX_I - YY_I \text{ for } I = N + 1, \dots, 2N \end{aligned} \quad (16)$$

The value of V_{rms} of the line voltage is given by:

$$V_{rms}^2 = (1 / 2N) \sum_{I=1}^{I=2N} Z_I^2 \quad (17)$$

The expression of the exact THD of the line voltage is thus given by:

$$\begin{aligned} THD &= \sqrt{\frac{\sum_{I=1}^{I=2N} Z_I^2}{2N V_{1rms}^2}} - 1, \text{ where :} \\ \sum_{I=1}^{I=2N} Z_I^2 &= \sum_{I=1}^{I=N/3} (X_I + X_{I+2N/3})^2 \\ &+ \sum_{I=1+N/3}^{I=N} (X_I + X_{-I+4N/3})^2 \\ &+ \sum_{I=N+1}^{I=4N/3} (X_{-I+2N+1} + X_{-I+1+4N/3})^2 \\ &+ \sum_{I=1+4N/3}^{I=2N} (X_{-I+2N+1} - X_{I-4N/3})^2 \dots \end{aligned} \quad (18)$$

The value of V_{HOrms} of the high order harmonics for the line voltage is still given by Eq. (10), with the THD substituted from Eq. (18).

OBTAINING THE VALUES OF X_I USING A MILP OPTIMIZATION MODEL

The obtained expressions for the exact THD require a previous knowledge of the values of the voltage levels X_I over equal subintervals of the quarter cycle of the main voltage. These values could be obtained when applying any of the methods that determine the switching angles of the MLI under certain elimination or reduction conditions on the low order harmonics. If the obtained switching angles have decimal fractions, then applying the deduced expressions for the THD may require dividing the

quarter cycle into very large number of subintervals and the calculations on the computer may take long time and thus an approximation may be an adequate solution. However, the author has introduced an optimization model using Mixed Integer Linear Programming (MILP) that determines directly the values of X_I that minimize any undesired harmonics and satisfy the required constraints (El-Bakry, 2009, 2010). Actually, this model has many advantages over other harmonic reduction methods (El-Bakry, 2013).

In this model the Fourier series coefficient V_{2m+1} of $F(wt)$ in Eq. (1) as function of X_I is deduced as:

$$V_{2m+1} = (4 / \pi) \int_0^{\frac{\pi}{2}} F(wt) \sin(2m + 1)wt dw$$

$$= [8 / \{\pi(2m + 1)\}] \sum_{I=1}^{I=N} X_I [\sin(2m + 1)\tau / 2 \dots \dots \dots \sin(2m + 1)(\theta_I + \tau / 2)]. \tag{19}$$

where : $m = 0, 1, \dots, \infty, \tau = \pi / 2N$
and $\theta_I = (I - 1)\tau$

The amplitude of the main harmonic corresponds to V_1 , i.e., by substituting $m = 0$ in Eq. (19). This equation shows that V_{2m+1} for any value of m is a linear function of $X_I, I = 1, 2, \dots, N$.

The MILP model determines the values of X_I that minimize the values of the undesired harmonics according to the optimization relations:

$$\text{Minimize } \in$$

$$V_1' - \Delta \leq V_1 \leq V_1' + \Delta \tag{20}$$

$$- \in \alpha_{2m+1} \leq V_{2m+1} \leq \in \alpha_{2m+1} \tag{21}$$

$$X_I \geq 0, \text{ for } I = 0, 1, \dots, N \tag{22}$$

In the main harmonic constraint (20), V_1' is the required amplitude of the main harmonic. Δ is a small incremental value, $\Delta \ll V_1'$, arbitrary chosen and included in the main harmonic constrain to ensure obtaining an optimum solution, since an equality constraint may give a high value of ϵ or even an unfeasible solution., due to the trigonometric nature of the constraints. The value of Δ is taken a very small fraction of V_1' , so that the obtained value of V_1 does not differ practically from the required value of V_1' .

In constraint (21) V_{2m+1} is given by Eq. (19), for V_1 and the undesired harmonics and α_{2m+1} is a weighting factor for the undesired harmonics, to enable reduction of the absolute values of the harmonics with different upper bounds according to their order.

Constraint (22) is the integer constraint on X_I .

Additional constraints on X_I may be added according to the nature of the problem. Some examples of these additional constraints are:

If the MLI has uniform steps output voltage, with possible voltage levels $0, E, 2E, \dots, LV E$, where LV is the number of positive levels, the values of X_I normalized w.r.t. E , must satisfy, (El-Bakry, 2010):

$$X_I \dots \text{integer}, I = 1, 2, \dots, N \tag{23}$$

$$X_I \leq LV \dots \dots, I = 1, 2, \dots, N \dots$$

If the MLI has uninformed steps output voltage, due to unequal input dc sources E_1, E_2, \dots, E_S , then X_I must satisfy, (El-Bakry, 2012):

$$X_I = \sum_{J=1}^{J=S} E_J (p_{IJ} - 1) \text{ and } : p_{IJ} = 0, 1 \text{ or } 2,$$

$$I = 1, 2, \dots, N, \text{ and } : J = 1, 2, \dots, S \tag{24}$$

The value of p_{IJ} will take the values 0, 1 or 2 according to whether E_J is subtracted, not considered, or added in the expression of X_I , respectively.

If the MLI is a cascaded MLI with a staircase output voltage waveform, similar to that in Fig. 2b, where LV is the number of positive levels, then X_I must satisfy (El-Bakry, 2010):

$$X_I \leq X_{I+1}, \text{ for } I = 1, 2, \dots, N - 1, \text{ and}$$

$$X_N \leq LV \tag{25}$$

Once all the parameters of this MILP model are given, an optimum solution could be obtained that gives the values of X_I and ϵ using any of the well known operations research software packages, e.g., "LINGO" software (LINDO Systems Inc., 2004).

In the next section two cases taken from the references are solved in details to show the advantages of this model.

CASE 1: A THREE PHASE CASCADED MLI WITH EQUAL DC SOURCES

Bin Nasr *et al.* (2010) considered eliminating the 5th, 7th, 11th and 13th harmonic in an 11-level three phase cascaded MLI with equal dc sources. The following switching angles are obtained for the subsequent five positive levels in the first quarter cycle of the staircase output voltage waveform, similar to that of Fig. 2b:

$$\Theta_1 = 5.5510^\circ, \quad \Theta_2 = 16.3669^\circ, \quad \Theta_3 = 23.2811^\circ,$$

$$\Theta_4 = 38.2607^\circ, \quad \Theta_5 = 58.699^\circ$$

The reference reported a total harmonic distortion given by 8.33%.

Calculating the exact THD: To apply Eq. (18) for calculating the exact THD of the line voltage, the quarter cycle is divided into $N = 180$ subintervals, such that each subinterval occupies $90/180 = 0.5^\circ$. The five switching angles are approximated, such that each subinterval takes single voltage level, to be:

$$\Theta_1 = 5.5^\circ, \Theta_2 = 16.5^\circ, \Theta_3 = 23.5^\circ, \Theta_4 = 38.5^\circ, \Theta_5 = 58.5^\circ$$

The software used in this study calculates the following values:

- The amplitude of the phase voltage main harmonic V_1
- The exact THD of the line voltage
- The percentage value of the rms value of high order harmonics from the 95th harmonic $\%V_{HO}$ relative to the rms main harmonic
- The value of THD₉₁ of the line voltage calculated till the 91st harmonic, using Eq. (2) for the non-triplen odd harmonics from the 5th till the 91st harmonic
- The maximum percentage absolute amplitude among all the non-triplen low order harmonics till the 91st harmonic $\%V_{hm}$ relative to the main harmonic amplitude

The obtained results are:

$$\begin{aligned} V_1 &= 5.29 \text{ (normalizes w.r.t., the inverter dc voltage)} \\ \%THD &= 6.3\% \\ \%V_{HO} &= 2.87\% \\ \%THD_{91} &= 5.6\% \\ \%V_{hm} &= 2.46\% \end{aligned}$$

In addition, the recorded percentage values of the 5th, 7th, 11th and 13th harmonics relative to the main harmonic are -1.42, 0.71, 1.69 and 0.65%, respectively. These low values replace the zero values assumed by the harmonic elimination method, due to the approximation made in the switching angles.

Solution using the MILP model: The MILP model is applied for the 11-level three phase cascaded MLI given by Bin Nasr *et al.* (2010), using the following assumptions:

- Taking the number of subintervals $N = 180$
- Taking constraint (20) to be $5.2 \leq V_1 \leq 5.6$
- Constraint (21) is considered in two cases:
 - Minimizing low order harmonics equally from the 5th harmonic till the harmonic order $2m+1$, for different values of $2m+1$ from 7 till 29 i.e., taking $\alpha_{2m+1} = 1$ for these values of $2m+1$:
 - Minimizing low order harmonics with increasing weight, i.e., taking $\alpha_{2m+1} = 2m+1$, for different values of m from 7 till 29

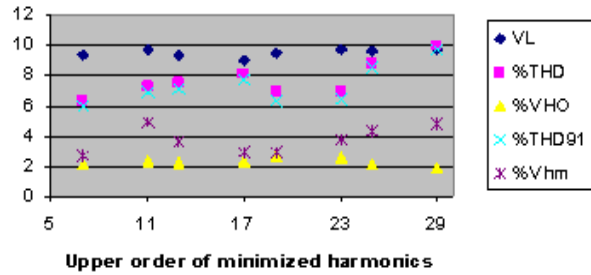

Fig. 5: Values when minimizing the harmonics equally

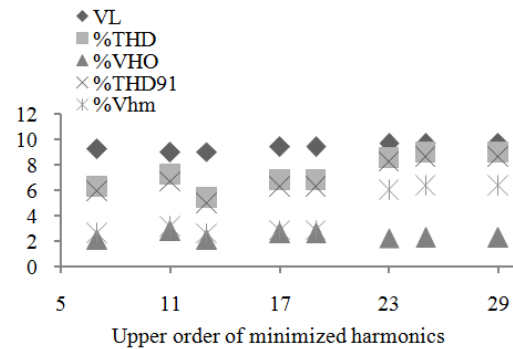

Fig. 6: Values when minimizing the harmonics increasingly

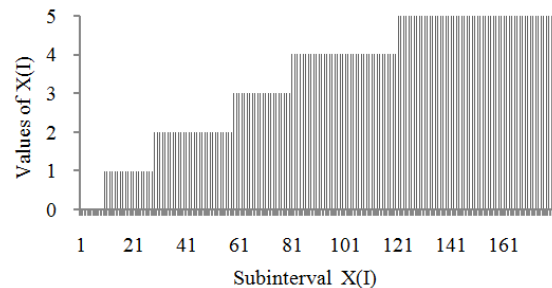

Fig. 7: Values of X (I) at %THD = 5.44%

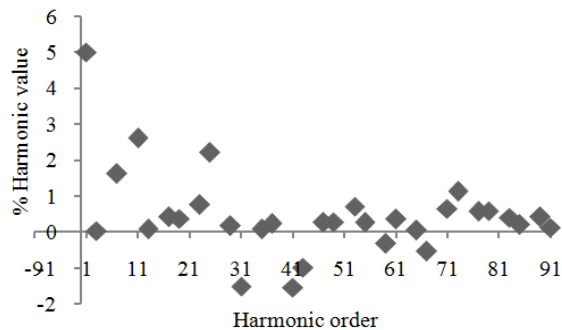

Fig. 8: % Values of harmonics at THD = 5.44%

- Adding constraints (22), (23) and (25), with the number of levels $LV = 5$

Figure 5 shows the obtained values of the amplitude of the line voltage V_L and the values of

%THD, %V_{HO}, %THD₉₁ and %V_{hm}, as defined before, for different values of m, minimizing all the harmonics, from the 7th till the 29th when minimizing the harmonics equally. Figure 6 shows the same values when minimizing these harmonics with increasing weight.

It is clear from Fig. 5 and 6 that the values of %THD and %THD91 are close to each other. The lowest THD is obtained by minimizing the low order harmonics with increasing weight till the 13th harmonic. This solution has the values:

$$\begin{aligned} V_L &= 9.06, \text{ normalized w.r.t., the input dc voltage;} \\ \%THD &= 5.44\% \\ \%V_{HO} &= 2.14\% \\ \%THD_{91} &= 5.0\% \\ \%V_{hm} &= 2.61\% \end{aligned}$$

For this solution, Fig. 7 shows the obtained values of X_I over the first quarter cycle. The voltage levels take the values 1, 2, 3, 4 and 5 corresponding to the switching angles $\Theta_1 = 4.5^\circ$, $\Theta_2 = 14^\circ$, $\Theta_3 = 29^\circ$, $\Theta_4 = 40^\circ$ and $\Theta_5 = 60^\circ$, respectively. Figure 8 shows the obtained values of the low order harmonics till the 91st harmonic and a 5% of the main harmonic.

CASE 2: A THREE PHASE CASCADED MLI WITH UNEQUAL DC SOURCES

Farokhnia *et al.* (2011) calculated the exact THD of the line voltage of an 11-level three phase cascaded MLI with the following values of the dc sources per phase:

$$V_{dc1} = 3, V_{dc2} = 2.5, V_{dc3} = 2, V_{dc4} = 1.5, V_{dc5} = 1 \text{ and all values are normalized w.r.t., a referenced voltage } E.$$

For the following switching angles within a quarter cycle of the output phase voltage: $\Theta_1 = 15^\circ$, $\Theta_2 = 25^\circ$, $\Theta_3 = 40^\circ$, $\Theta_4 = 55^\circ$, $\Theta_5 = 60^\circ$, the calculated exact %THD was 7.9194%.

Calculating the exact THD: Applying Eq. (18) to calculate the exact THD of the line voltage corresponding to the above switching angles, it is enough to take the number of subintervals $N = 18$, such that each subinterval has a width of 5° .

For given switching angles, the following values are obtained for the quantities defined before:

$$\begin{aligned} V_1 &= 10.257 \text{ (normalized w.r.t., the reference dc voltage)} \\ \%THD &= 7.9193\% \\ \%V_{HO} &= 2.4261\% \\ \%THD_{91} &= 7.5385\% \\ \%V_{hm} &= 4.7322\% \end{aligned}$$

The calculated THD agrees with Farokhnia *et al.* (2011).

Table 1: Solutions with different values of N

	N = 18	N = 36	N = 45
V _L	17.060	18.030	18.060
%THD	5.120	2.730	2.380
%V _{HO}	2.480	1.640	1.500
%THD ₉₁	4.480	2.180	1.850
%V _{hm}	2.860	1.060	1.200

Solution using the MILP model: The MILP model is applied to this case. Since the dc sources are unequal, constraints (24) about the values of X_I are considered instead of the integer constraints (23). Constraints (24) allow switching on dc sources positively or negatively during the quarter positive cycle while keeping positive values of X_I. In this case, by switching the dc source V_{dc4} positively or negatively during the quarter cycle, X_I can take any of the values 0.5, 1, 1.5, 2, 2.5, ..., 8.5, 9 and 10. Thus 19 positive values of X_I could be achieved and the MLI can operate as a39-level inverter and this will reduce greatly the THD.

Actually, incorporating constraint (24) in the MILP model will introduce many redundant levels, i.e., levels with the same value obtained by different values of the dc sources and will cause the software program to go into large number of loops without improving the solution and this increases greatly the solution time. To avoid this, constraints (24) are replaced by the constraints, for I = 1, 2, N:

$$\begin{aligned} X_I &= 10 - P_I - 1.5Q_I, X_I \geq 0 \\ P_I &\text{ integer, } P_I \leq 10, \\ Q_I &\text{ binary} \end{aligned}$$

If Q_I takes the value 0, then X_I can take one of the integer values 0, 1, ..., 10. While if Q_I takes the value 1, the X_I can take one of the values 0, 5, 1.5, ..., 8.5. There will be no redundant levels.

In addition to this constraint, the main constraints (20), (21), (22) and (25) are included into the MILP model. The model is solved to minimize the harmonics of order 5, 7, 11, ... till 31 equally. Table 1 gives the obtained values of V_L, %THD, %V_{HO}, %THD₉₁ and %V_{hm} as defined before, when taking the number of subintervals N = 18, 36, 45 and constraint (20) to be $9.75 \leq V_1 \leq 10.75$.

Increasing the number of subintervals N may lead to solutions with lower THD. However, the obtained values corresponding to N = 45 are very satisfactory, since they satisfy IEEE standard 519-1992 (1993) for voltage distortion limits in power systems, which puts upper limits of 2.5 and 1.5% for %THD and %V_{hmax} respectively, where %V_{hmax} is the maximum percentage absolute amplitude among all the harmonics from the 5th till ∞ , for output voltages between 69 and 161 kv.

To investigate some possible solutions for N = 45, the model is resolved to minimize all the harmonics equally till the harmonic of order 2m+1 for the values 2m+1 = 25, 29, ... and 41. Figure 9 shows the obtained corresponding values for %THD, %V_{HO}, %THD₉₁ and %V_{hm}.

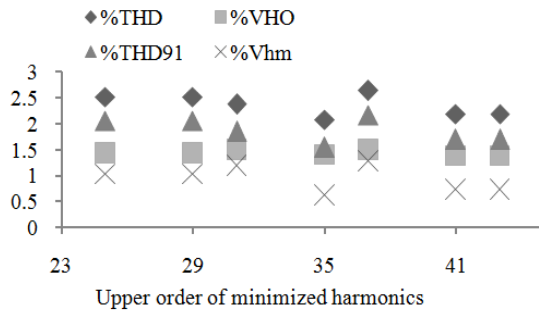

Fig. 9: Values when minimizing the harmonics equally

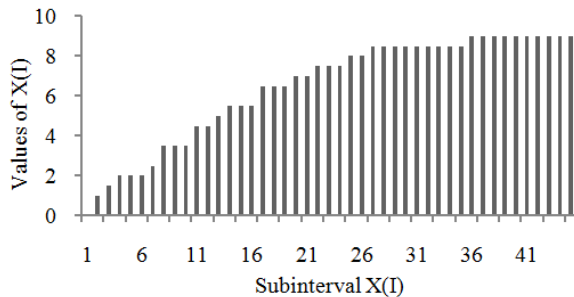

Fig. 10: Values of X (I) at %THD = 2.08%

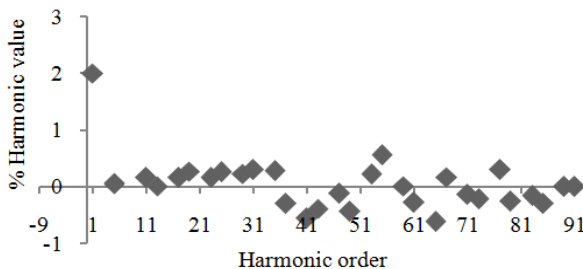

Fig. 11: % Values of harmonics at %THD = 2.08%

From Fig. 9, the least %THD among these values is obtained when minimizing the harmonics equally till the 35th harmonics, with a value 2.08% at $V_L = 17.04$. For this solution, Fig. 10 shows the obtained values of X_1 over the first quarter cycle. The voltage levels take the values 1, 1.5, 2, 2.5, 3.5, 4.5, 5, 5.5, 6.5, 7, 7.5, 8, 8.5 and 9 corresponding to the switching angles $\theta_1 = 2^\circ$, $\theta_2 = 4^\circ$, $\theta_3 = 6^\circ$, $\theta_4 = 12^\circ$, $\theta_5 = 14^\circ$, $\theta_6 = 20^\circ$, $\theta_7 = 24^\circ$, $\theta_8 = 26^\circ$, $\theta_9 = 32^\circ$, $\theta_{10} = 38^\circ$, $\theta_{11} = 42^\circ$, $\theta_{12} = 48^\circ$, $\theta_{13} = 52$ and $\theta_{14} = 70^\circ$, respectively. The inverter operates as a 29-level inverter, which causes the THD to decrease greatly.

Figure 11 shows the obtained values of the low order harmonics till the 91st harmonic and a 2% of the main harmonic.

CONCLUSION

This study has derived simple expressions for calculating the exact THD of MLIs, which are much simpler than that derived by Farokhnia *et al.* (2011).

The derivation of these formulas depends on dividing the quarter cycle of the time interval of the output voltage into a large number of equal subintervals and associating with each subinterval a certain single voltage level value. These formulas could be applied for MLIs that applies any harmonic elimination or reduction technique, so long as the switching angles of the phase voltage are known and it is specially suitable when applying a Mixed Integer Linear Programming (MILP) model for determining the switching angles that minimize the values of any undesired harmonics, since it takes the values of X_1 directly from the model solution.

Two examples taken from the references are analyzed. In the first example the exact switching angles are approximated to the nearest half angle to enable dividing the quarter cycle of the time interval of the output voltage into $N = 180$ subintervals, each with a single voltage level. However, this approximation has affected slightly the values of the output harmonics and their corresponding THD. This shows that the derived formulas could be applied even with switching angles that have decimal fractions. The obtained exact THD by solving the MILP model is less than given in the reference.

In the second example a cascaded MLI with unequal dc sources is considered. A MILP model is applied to solve this problem, that enables switching on one or more of the dc sources positively or negatively during the positive quarter cycle of the output voltage while keeping positive voltage levels. By this way the number of positive levels increases greatly and as a result the exact THD is reduced.

A solution of the model gives an exact % THD = 2.08%, compared to an exact THD = 7.919% given in the reference. The solution obtained satisfies the IEEE standard 519-1992 for voltage distortion limits in power systems, which puts upper limits of 2.5 and 1.5% for %THD and $\%V_{hmax}$, respectively for output voltages between 69 and 161 kv.

REFERENCES

Ahmadi, D., K. Zou, L. Cong, Y. Huang and J. Wang, 2010. A universal selective harmonic elimination method for high power inverters. IEEE T. Power Electron., 26(10): 2743-2752.

Ben Nasr, M.N., A. Kebir and F.B. Ammar, 2010. Cascaded h-bridges symmetrical 11-level optimization. Proceedings of 14th International Middle East Power Systems Conferences (MEPCON'2010). Cairo, Egypt, pp: 465-470.

Carnielutti, F., H. Pinheiro and C. Rech, 2012. Generalized carrier-based modulation strategy cascaded multilevel converters operating under faulty conditions. IEEE T. Ind. Electron., 59(2): 679-689.

Cecati, C., F. Cianetta and P. Siano, 2010. A multilevel inverter for photovoltaic systems with fuzzy logic control. IEEE T. Ind. Electron., 57(12): 4115-415.

- Dixon, J., J. Preda, C. Castillo and S. Bosch, 2010. Asymmetrical multilevel inverters for traction drives using only one DC supply. *IEEE T. Veh. Technol.*, 59(8): 3736-3743.
- El-Bakry, M., 2009. Selective harmonic minimization for multilevel inverters. *Proceeding of 2nd International Conference Computer and Electrical Engineering (ICCEE)*, 2: 341-346.
- El-Bakry, M., 2010. Using linear programming models for minimizing harmonics values in cascaded multilevel inverters. *Proceeding of 2010 IEEE/ASME International Conference on Advanced Intelligent Mechatronics (AIM'2010)*, pp: 696-702.
- El-Bakry, M., 2012. Minimizing bnharmonics values in non-uniform step asymmetric CMLIs. *Int. J. Emerg. Technol. Adv. Eng.*, 2(10): 5-11.
- El-Bakry, M., 2013. Applying MILP for 27-level CMLI to obtain low THD values over wide voltage range. *J. Energ. Power Eng.*, 5(4): 315-321.
- El-Hamrawy, O.I., M. El-Bakry and H.A. Konbor, 2010. Implementing a three phase nine-level cascaded multilevel inverter with low harmonics values. *Proceedings of the 14th International Middle East Power Systems Conference (MEPCON'2010)*, pp: 983-987.
- Farokhnia, N., H. Vodizah, S.H. Fathi and F. Anvariast, 2011. Calculating the formula of line-voltage THD in MLI's with unequal DC sources. *IEEE T. Ind. Electron.*, 58(8): 3359-3372.
- Filho, F., H.Z. Maia, T.H.A. Mateus, B. Ozpineci, L.M. Tolbert and J.O.P. Pinto, 2013. Adaptive selective harmonic minimization based on ANNs for cascaded multilevel inverters with varying DC Sources. *IEEE T. Power Electron.*, 60(5): 1955-1962.
- Ge, B., Z.P. Fang, A.T. de Almeida and H. Abu-Rub, 2010. An effective control technology for medium voltage high-power induction motor fed by cascaded neutral-point-clamped inverter. *IEEE T. Ind. Electron.*, 57(8): 2659-2668.
- Gultekin, B., C.O. Gercek, T. Atalik, M. Deniz, N. Bicer, M. Ermis, M. Kosek, I. Cadirci, A. Acik, Y. Akkays, H. Toygar and S. Bidecis, 2012. Design and implementation of 154 KVA 50-Mvar transmission STATCOM Based on 21-level cascaded multilevel inverter. *IEEE T. Ind. Appl.*, 48(3): 1030-1045.
- IEEE Standard 519-1992, 1993. *IEEE Recommended Practices and Requirements for Harmonic Control in Electrical Power Systems*. IEEE Industry Applications Society.
- Kavousi, A., B. Vahidi, R. Salehi, M. Bakhshizadeh, N. Farokhnia and S.S. Fathi, 2012. Application of the bee algorithm for selective harmonic elimination strategy in multilevel inverters. *IEEE T. Power Electron.*, 27(4): 1689-1696.
- Khoucha, F., M.S. Lagoam, A. Kheloui and M.E. Benbouzid, 2011. Comparison of symmetrical and asymmetrical three phase H-bridge MLI for DTC induction motor drives. *IEEE T. Energy Conver.*, 26(1): 64-72.
- Kumar, J., B. Das and P. Agarwal, 2009. Harmonic reduction technique for a cascaded multilevel inverter. *Int. J. Recent Trends Eng.*, 1(3): 181-185.
- Leon, J.I., S. Kouro, S. Vazquez, R.C. Portillo, L.G. Franqueb, J.M. Carrasco and J.R. Rodriguez, 2011. Multidimensional modulation technique for cascaded multilevel inverters. *IEEE T. Ind. Electron.*, 58(2): 412-420.
- Lindo Systems Inc., 2004. *Optimization Modeling with LINGO*. Retrieved from: www.lindo.com.
- Malinowoki, M., 2010. A survey on cascaded multilevel inverters. *IEEE T. Ind. Electron.*, 57(7): 2197-2206.
- Napoles, J., A.J. Watsen, J.J. Padilla, J.J. Leon, L.J. Franquelo, P.W. Wheeler and M.A. Aguirre, 2013. Selective harmonic mitigation technique for cascaded h-bridge converters with nonequal DC line voltages. *IEEE T. Ind. Electron.*, 60(5): 1963-1971.
- Rahim, N.A., K. Chanjago and J. Selarai, 2011. Single phase seven-level grid connected inverter for photovoltaic system. *IEEE T. Ind. Electron.*, 58(6): 2435-2443.
- Seyezhai, R. and B.L. Mathur, 2010. Implementation and control of variable frequency ISPWM technique for an asymmetric multilevel inverter. *Eur. J. Sci. Res.*, 39(4): 558-568.
- Sing, B., N. Mittal, K.S. Vermak, D. Sing, S.P. Singh, R. Dixit, M. Singh and A. Baranawal, 2012. Multilevel inverters: A literature survey on topologies and control strategies. *Proceeding of 2nd International Conference on Power, Control and Embedded Systems (ICPCES)*, pp: 1-11.
- Sujanarko, B., M. Ashri, M.H. Parnomo, O. Penangsang and Soebagyo, 2010. Advanced carrier based PWM in asymmetric cascaded multilevel inverter. *Int. J. Elect. Comput. Sci. IJECS-IJENS*, 10(6): 47-51.
- Wanjekche, T., D.V. Nicolae and A.A. Jimoh, 2011. *Modeling, Control and Simulation of Cascaded 3-5-9 Hybrid Inverter Topology for Grid Interface Applications*. Smart Power Grids, Springer, Berlin, Heidelberg, pp: 479-514.
- Yousefpoor, N., S.H. Fathi, N. Farokhnia and H.A. Abyaneh, 2012. Total harmonic distortion minimization applied directly on the line-to-line voltage of multilevel inverters. *IEEE T. Ind. Electron.*, 59(1): 373-380.
- Zhong, Q. and T. Hornik, 2012. *Control of Power Inverters in Renewable Energy and Smart Grid Integration*. Wiley-IEEE Press, pp: 1-25.