

Research Article

Study on Design Method of Amphibious Environment-friendly Car for Sightseeing

Xiaowei Jiang

Institute of Machinery and Vehicle Engineering, Changchun University, Changchun 130022, China

Abstract: The aim of this study is to design a small mechanical amphibious sightseeing car, of which the shape is beautiful, the structure is simple and reasonable, the technical content is high, manufacturability is good, the cost is low, the operation is convenient and the safety performance is good and which is in line with the ergonomics, meets the environment-friendly demand and achieves the double function of traveling in water and on ground. This study specifically researches its structure design, humanization design, security design and appearance design, including the shape design and color design. And then its market prospect is analyzed. On this basis, the corresponding conclusions are reached.

Keywords: Amphibious sightseeing car, color design, shape design, structure design

INTRODUCTION

Amphibious car has excellent unimpeded performance, which could cross mountains and river, not restricted, so it could play an enormous role in the military, transportation, disaster rescue, exploration survey and other professional fields (Xiao, 2008). Amphibious car was applied in the military field in the beginning, deriving from the military landing craft during WWII, after the development of transformation, usually applied for tourism and leisure (Wang *et al.*, 2004).

Currently, amphibious tourism projects are popular in the developed country, which have operated for many years in Brisbane of Australia, Singapore, Ottawa, Montreal, Toronto and Nova Scotia of Canada, New York, Washington, Miami, Philadelphia, George and many other cities of the United States. In 2001, 36 shipping experts including engineers who are from Australia, Italy, the United States, Germany, Britain and China gathered in Australia's gold coast. They constantly developed and updated the speed, performance and function of amphibious vehicle and after 5 years development, finally they created the Australia international amphibious cruise ship-"adventure duck" amphibious sightseeing ship, costing millions. Amphibious projects were further applied to tourism industry, used in Cairns, Brisbane and other famous tourist resorts.

In 2009, Qingdao Shengshifeiyang sea cruises co., LTD. (China Shengshi investment co., LTD., a wholly owned subsidiary), conforming to the trend of The Times, introduced the Australian "adventure duck" amphibious ship to Qingdao coast in China and applied it to carry out amphibious sightseeing tourism, filling

the gaps in China's tourism market, which has opened up a new thought for China's tourism market.

In recent years, aiming at the shortcomings of the amphibious ship introduced from abroad and some suggestions and requirements of the masses of tourists, China Shengshi investment co., LTD. organizes domestic several military enterprise, purchase advanced vehicle technology in Australia and South Korea and set up the only officially certified "amphibious ship" research and development center and final assembly base, continuously to improve the amphibious ship, successively researching, designing and creating the second and third generation duck "adventure" amphibious ship with China's independent intellectual property rights and putting into daily operations, which is safer, more comfortable and more luxurious and is loved by tourists (Xin and Wang, 2007).

Because of its excellent unimpeded performance, amphibious car has its unique operating advantages in the tourist cities or scenic spots which have the advantages of regional integration of tourism landscape, plentiful tourists and compound requirements within the waters. Amphibious car must have huge development space and market prospects (Wu *et al.*, 2004).

But the existing research also has certain problem (Jiang, 2013a). This kind of large amphibious ship is expensive and its application scope is limited, not suitable for small lake waters in parks or amusement park, such as "adventure duck"; It lacks the research on small mechanical amphibious ship, low degree of popularity; It lacks the characteristics of energy-saving and environmental protection and the fitness function. Therefore, the aim of this study is to solve these problems, so as to design a small mechanical amphibious car, in order to fill the blank of the market.



Fig. 1: Three-dimensional modeling of the amphibious environment-friendly car for sightseeing



(a)



(b)

Fig. 2: The water rendering

DESIGN METHODS

Appearance design:

Shape design: In the shape design of amphibious environment-friendly car for sightseeing, above all, the inside quality and using safety must be ensured. Never only pursue the scale and patten beauty of shape design, so as to reduce the man-machine nature and other technique function index. The various components of amphibious car compose of some geometry bodies composed of dot, line, face. The shape design of amphibious car is combining the material techniques such as structure and function of slicer and art contents together, forming a 3D space stereoscopic shape, which has to correspond to art rule, masterly makes use of shape composing principle and masters shape appearance characteristic and forming psychology and vision error of related shape, that is important means to acquire amphibious car of generous beauty and novel style (Qiu, 2005), as shown in Fig. 1.

According to the vehicles and ships technique and industrial design theory, the author putts forward the research on amphibious environment-friendly car for sightseeing. Giving priority to ship and combining vehicle and ship is the overall guiding thought of ship design of amphibious environment-friendly car for sightseeing. To minimize the wave-making resistance, bow line adopts streamline, as shown in Fig. 2.

Color design: The color design is an important constituent part of the modeling design of the amphibious environment-friendly car for sightseeing, as color has more ocular, more strong and more attractive

magic power than the body. The color could firstly influence the person's sense organs than the body, so it should attach great importance to the color design. The color design of the amphibious environment-friendly car for sightseeing should follow the following few important points.

Satisfy the request of man-machine coordination:

The color design of the amphibious environment-friendly car for sightseeing should well embody the relation of man-machine coordination, so as to make person's mood pleasant and have a sense of security. For example, generally, the body of amphibious car properly adopts bright color, so as to get rid of depressed feeling, satisfying the request of man-machine coordination.

Value the choice of tone: The choice of main tone of the amphibious environment-friendly car for sightseeing is a problem of very importance; the different tone will form different art effect. In matching color of the amphibious car, having main tone can seem to be to unify. The color is more little, the main body characteristic is more strong, the decorate characteristic is more good and the external form relation of the amphibious environment-friendly car for sightseeing is more unify (Jiang, 2011). Contrary, the color matches more much, causing the color more disorderly, so that it is difficult to adjust generally, the main body characteristic is unclear and the harmonious effect is broken.

The choice of tone still needs to notice whether unique beauty. It needs to hold tight people's mental request for the color of the amphibious environment-friendly car for sightseeing, transform the tone of the amphibious car to make it produce an unusual attraction, in the meantime, increase the category of tone to satisfy people's fondness for different colors (Fu, 2002).

Moreover, the body of amphibious car is suitable to use a color of relatively high lightness as the main body color and use clear, elegant and clean color to unify overall situation to make the main tone definite. Using little area of high purity color to embellish to make the whole seem to be abundant, change and organic. The whole color generally uses monochrome or two sets of colors, not more than three sets of colors (Fu, 2002).

Notice novelty: The color design of the amphibious environment-friendly car for sightseeing should also notice novelty and creativity to make it have vitality and more competitiveness. The color of the amphibious car not only can satisfy the request for appreciating beauty, under the particular condition, but also has strong influence, which can cause the transfer of people's emotion and interest to attract people's attention. For example, on an international industrial product exhibition, a red numerical control machine tool produced by Germany appeared in the mechanical exhibition hall. Though the red is not the color that the

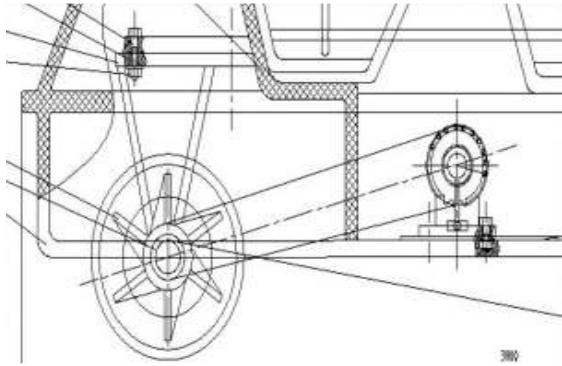

Fig. 3: Power transmission diagram

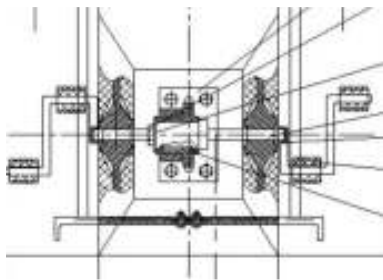

Fig. 4: Foot pedal transferring power

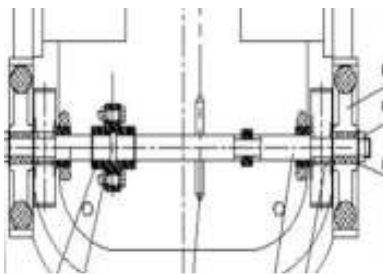

Fig. 5: Rear wheel drive

numerical control machine tool consistently uses, the factory surprisingly adopted red color to decorate numerical control machine tool, causing the purchaser to crowd in its vicinity and then understood its function characteristics, which produced a surprising sensation effect and made its order enormously exceeded other nation. It is thus clear that the novelty of color design is very important.

Match the new age request of appreciation beauty: With the progress of the age, the improvement of people's living standard and the increase of cultural art accomplishment, the appreciating beauty standards also change. In a certain period or a certain region or world scope, some colors are popular of people and are extensively popular, becoming the "popular color". The "popular color" has a strong age characteristic, as a result, in a period, it become the color which is used extensively. The color design of the amphibious environment-friendly car for sightseeing also should

sufficiently consider using the "popular color" to accord with the age request.

Structure design:

Confirm the overall design scheme: Through demonstration and simulation calculation, the author makes scheme screening to select the excellent one and finally determines the overall design scheme that the rudder is arranged front and the pedal drive is arranged in the middle. Such design that the center of gravity is low and the axial load distribution is reasonable is advantageous to the boat balance in water and climbing on ground. In particular, the rudder is arranged front, which changes the consistent practice that ships have always controlled the direction by stern rudder. It boldly adopts a front wheel to control the orientation. So, even if it sails in water, just as on land. Easily manipulating the handle of the direction just could drive freely, which not only avoids a lot of troubles on the operation, but also provides great convenience for drivers.

Research the aquatic motion mechanism and ground motion mechanism and the drive system:

Through argumentation and selecting the optimal scheme, ultimately it is determined that the aquatic motion mechanism consists of two propellers and a rudder; the ground motion mechanism consists of two rear wheels and a front wheel. To get the optimal design, the front wheel acts as a rudder in water, then connecting the front wheel and the handle of manipulating direction, so as to realize the steering. It could realize the movement by pedaling the pedal device with feet, transferring the power to the propellers and the rear wheels, as shown in Fig. 3 to 5. In this way, the two manners of driving in water and on land respectively share a set of transmission system, which is not only simple and reasonable, but also achieves the research goal of low cost.

Research the concrete structure and the design of all parts of the amphibious environment-friendly car for sightseeing:

According to the theory of mechanical design, after repeated research, finally it is determined the hull front end is equipped with a front wheel which is connected with the handle of manipulating the direction. The part of front-wheel hub does not set hole, so the front wheel could act as a rudder when sailing in water. The hull backend is equipped with the rear axle of which both ends are equipped with the rear wheels of which the insides are equipped with the propellers. Hull inside backend is equipped with two seats of which the front is the handle of manipulating direction, which makes the two persons who sit at the back all control direction, avoiding the fatigue of one person driving for a long time. Hull inside is also equipped with the pedal drive device which connects the rear axle through the chain. The front end of hull inside is equipped with two swivel chairs in order to make the two persons who sit

in the front row change the sitting direction optionally and make the tourism freer and more comfortable.

Humanization design: Humanization design means the design of emphasizing the mental and emotional needs on the basis of meeting person's material needs. The core of humanization design is "people-oriented" thinking, endowing design with humanistic care. When the tourism, tourists often prone to tired because of running, this will often affect the mood. So the design of the amphibious environment-friendly car for sightseeing as the means of transport, should give the passengers humanistic care. Using humanization design to ease the exhaustion of passengers is especially important (Wei and Jiang, 2012).

The backend inside hull is equipped with two seats and in front of the seats it is the handle of steering direction, such making the two person sitting backend all control direction, avoiding the fatigue of one person driving for a long time; the front end inside hull is equipped with two swivel chairs, in order to make the two person sitting in the front row free to change the sitting direction, making the tourism more free and more comfortable. Simple and reasonable manipulation way, comfortable seats, open vision field and related safety protection measures all embody the humanization design.

Security design: Security cannot be ignored in the vehicle design, especially the sightseeing car. This amphibious environment-friendly car for sightseeing not only needs to travel in water, but also needs to travel on ground, so the security design is very necessary. When traveling in water, it will encounter more situations than on ground and sometimes it is unpredictable. So, in order to prevent one thousand, in the design there is a cylindrical storage room for life jacket under each of chair (Wei and Jiang, 2012).

Second, it adds many armrests in the internal space, which is convenient for people to grasp, protecting people in the process of vehicle traveling.

SIGNIFICANCE AND PROSPECTS

Study and design on amphibious environment-friendly car for sightseeing will fill a void of tourism in our country (Jiang, 2013b). Because of its amphibious special function, it could widely apply to agriculture, health, public security and all fronts. Used as a means of transportation of tourism, it has more unique superiority.

In addition, the opening of market economy inevitably leads products to constantly update. Tourism appliances as the goods are no exception. The shift from unitary type to versatility is the modern economy of rapid development demand for industrial products. Therefore, the amphibious environment-friendly car for sightseeing will be popular with the whole society and the development prospect is good (West and Deng, 2010). According to preliminary investigation, people

are very eager to the amphibious tourism appliance. It is believed that it is once available and it will be in short supply.

The amphibious environment-friendly car for sightseeing not only has the very high social benefits, but also its economic benefits will be considerable (Zhang, 2000). According to preliminary estimation, a single cost could be controlled in about RMB 9,000 Yuan and the lowest selling price could be set at RMB 12,000 Yuan. If establishing a amphibious car company whose annual output is 5000 amphibious cars, it not only could solve the employment problem of about 600 people, but also provide tax turnover of about RMB 4 million Yuan for the country every year.

CONCLUSION

This research is to design a mechanical amphibious car of small type, filling the gap on the market. It is suitable for small lake waters and has high popularity degree. The two manners of driving in water and on land respectively share a set of transmission system, which is simple and unique. In addition, it drives the boat trip through manpower with pedal way, which is energy-saving and has environmental protection and very good fitness effect. In particular, the rudder is arranged front, which changes the consistent practice that ships have always controlled the direction by stern rudder. It boldly adopts a front wheel to control the orientation.

At the same time, the design of the amphibious environment-friendly car for sightseeing, of which the shape is beautiful, the structure is simple and reasonable, the technical content is high, manufacturability is good, the cost is low, the operation is convenient and the safety performance is good, is in line with the ergonomics, meets the demand of tourism, fitness and entertainment and achieves the double function of traveling in water and on ground.

ACKNOWLEDGMENT

This study is supported by the Twelfth Five-Year Science and Technology Research Project of Education Department of Jilin Province under the grant No. 2014530.

REFERENCES

- Fu, L., 2002. Research on Modeling Design of Industrial Product. Jilin People Press, Changchun, pp: 129-133.
- Jiang, X., 2011. Discussion on the modeling design of new times table lamp. *Adv. Mat. Res.*, 295-297: 2581-2584.
- Jiang, X., 2013a. Design and research on household food slicer. *Adv. J. Food Sci. Technol.*, 5(10): 1296-1300.

- Jiang, X., 2013b. Design and application on mini type food slicer. Adv. J. Food Sci. Technol., 5(10): 1322-1324.
- Qiu, S., 2005. Modeling Design Basis. Tsinghua University Press, Beijing, pp: 55-64.
- Wang, W., K. Wu, F. Zhao, Z. Xin and B. Liu, 2004. Analyses on military amphibious vehicle. Auto Appl., 10: 27-30.
- Wei, Y. and Y. Jiang, 2012. Analyses on interior space design of amphibious bus for sightseeing tour. Market Modernization, pp: 53-54.
- West, B. and S. Deng, 2010. Thin layer chromatography methods for rapid identity testing of *Morinda citrifolia* L. (Noni) fruit and leaf. Adv. J. Food Sci. Technol., 2(5): 298-302.
- Wu, K., W. Wang and F. Zhao, 2004. Present situation and development trend of military amphibious vehicle. Spec. Purpose Vehicle, 2: 15-16.
- Xiao, F., 2008. Amphibious all-terrain vehicles used in rescue and relief work. Fire Contr. Technol. Prod. Inform., 11: 93.
- Xin, Z. and W. Wang, 2007. Technology development of high speed amphibious vehicle. Spec. Purpose Vehicle, 6: 18-21.
- Zhang, J., 2000. Design characteristics and market prospects of amphibious vessel. Shipbuild. Technol., 5: 36-37.